

NOTICE

AT THE TIME OF ISSUANCE, THIS INFORMATION MANUAL WAS AN EXACT DUPLICATE OF THE OFFICIAL PILOT'S OPERATING HANDBOOK AND FAA APPROVED AIRPLANE FLIGHT MANUAL AND IS TO BE USED FOR GENERAL PURPOSES ONLY.

IT WILL NOT BE KEPT CURRENT AND, THEREFORE, CANNOT BE USED AS A SUBSTITUTE FOR THE OFFICIAL PILOT'S OPERATING HANDBOOK AND FAA APPROVED AIRPLANE FLIGHT MANUAL INTENDED FOR OPERATION OF THE AIRPLANE.

THE PILOT'S OPERATING HANDBOOK MUST BE CARRIED IN THE AIRPLANE AND AVAILABLE TO THE PILOT AT ALL TIMES.

Cessna Aircraft Company
Original Issue - 27 October 2006
Revision 1 - 20 December 2007

PERFORMANCE - SPECIFICATIONS

***SPEED:**

Maximum at Sea Level	150 KNOTS
Cruise, 80% Power at 7000 Feet.	145 KNOTS

CRUISE: Recommended lean mixture with fuel allowance for engine start, taxi, takeoff, climb and 45 minutes reserve.

80% Power at 7000 Feet	Range - 773 NM
87 Gallons Usable Fuel	Time - 5.4 HOURS
75% Power at 8000 Feet	Range - 813 NM
87 Gallons Usable Fuel	Time - 5.8 HOURS
Max Range at 10,000 Feet, 55% Power	Range - 930 NM
87 Gallons Usable Fuel	Time - 7.6 HOURS

RATE OF CLIMB AT SEA LEVEL 924 FPM

SERVICE CEILING 18,100 FEET

TAKEOFF PERFORMANCE:

Ground Roll	795 FEET
Total Distance Over 50 Foot Obstacle	1514 FEET

LANDING PERFORMANCE:

Ground Roll	590 FEET
Total Distance Over 50 Foot Obstacle	1350 FEET

STALL SPEED (KCAS):

Flaps Up, Power Off54 KCAS
Flaps Down, Power Off49 KCAS

(Continued Next Page)

PERFORMANCE - SPECIFICATIONS (Continued)

MAXIMUM WEIGHT:

Ramp	3110 POUNDS
Takeoff	3100 POUNDS
Landing	2950 POUNDS

STANDARD EMPTY WEIGHT 1924 POUNDS

MAXIMUM USEFUL LOAD 1186 POUNDS

BAGGAGE ALLOWANCE 200 POUNDS

WING LOADING: 17.8 lbs/sq. ft.

POWER LOADING: 13.5 lbs/HP

FUEL CAPACITY 92 GALLONS

OIL CAPACITY 9 QUARTS

ENGINE: Textron Lycoming IO-540-AB1A5
230 BHP at 2400 RPM

PROPELLER: 3-Bladed, Constant Speed, Diameter. 79 INCHES

NOTE

* Speed performance and range are shown for an airplane equipped with the standard wheel and brake fairings. These fairings increase the speeds approximately 3 knots over an airplane without the fairings.

The above performance figures are based on the indicated weights, standard atmospheric conditions, level, hard-surface dry runways and no wind. They are calculated values derived from flight tests conducted by Cessna Aircraft Company under carefully documented conditions and will vary with individual airplanes and numerous factors affecting flight performance.



Information Manual

SKYLANE



Cessna Aircraft Company

Model 182T
NAV III AVIONICS OPTION - GFC 700 AFCS
Serials 18281869 and 18281876 and On

THIS MANUAL INCORPORATES INFORMATION ISSUED IN THE PILOT'S OPERATING HANDBOOK AND FAA APPROVED AIRPLANE FLIGHT MANUAL AT REVISION 1, DATED 20 DECEMBER 2007 (PART NUMBER 182TPHBUS-01).

COPYRIGHT © 2006
CESSNA AIRCRAFT COMPANY
WICHITA, KANSAS USA

182TIMBUS-01

TABLE OF CONTENTS

	SECTION
GENERAL	1
LIMITATIONS	2
EMERGENCY PROCEDURES	3
NORMAL PROCEDURES	4
PERFORMANCE	5
WEIGHT AND BALANCE/EQUIPMENT LIST	6
AIRPLANE AND SYSTEMS DESCRIPTION	7
HANDLING, SERVICE AND MAINTENANCE	8
SUPPLEMENTS	9

GENERAL

TABLE OF CONTENTS

	Page
Three View - Normal Ground Attitude	1-3
Introduction	1-5
Descriptive Data	1-5
Engine	1-5
Propeller	1-5
Fuel	1-6
Fuel Capacity	1-6
Oil	1-7
Oil Specification	1-7
Oil Capacity	1-7
Maximum Certificated Weights	1-8
Weight In Baggage Compartment - Normal Category	1-8
Standard Airplane Weights	1-8
Cabin And Entry Dimensions	1-8
Baggage Space And Entry Dimensions	1-8
Specific Loadings	1-8
Symbols, Abbreviations And Terminology	1-9
General Airspeed Terminology And Symbols	1-9
Meteorological Terminology	1-10
Engine Power Terminology	1-10
Airplane Performance And Flight Planning Terminology	1-12
Weight And Balance Terminology	1-13
Metric/Imperial/U.S. Conversion Charts	1-15
Weight Conversions	1-16
Length Conversions	1-18
Distance Conversions	1-22
Volume Conversions	1-23
Temperature Conversions	1-26
Pressure Conversion	1-27
Volume To Weight Conversion	1-28
Quick Conversions	1-29/1-30

THREE VIEW - NORMAL GROUND ATTITUDE

B3143

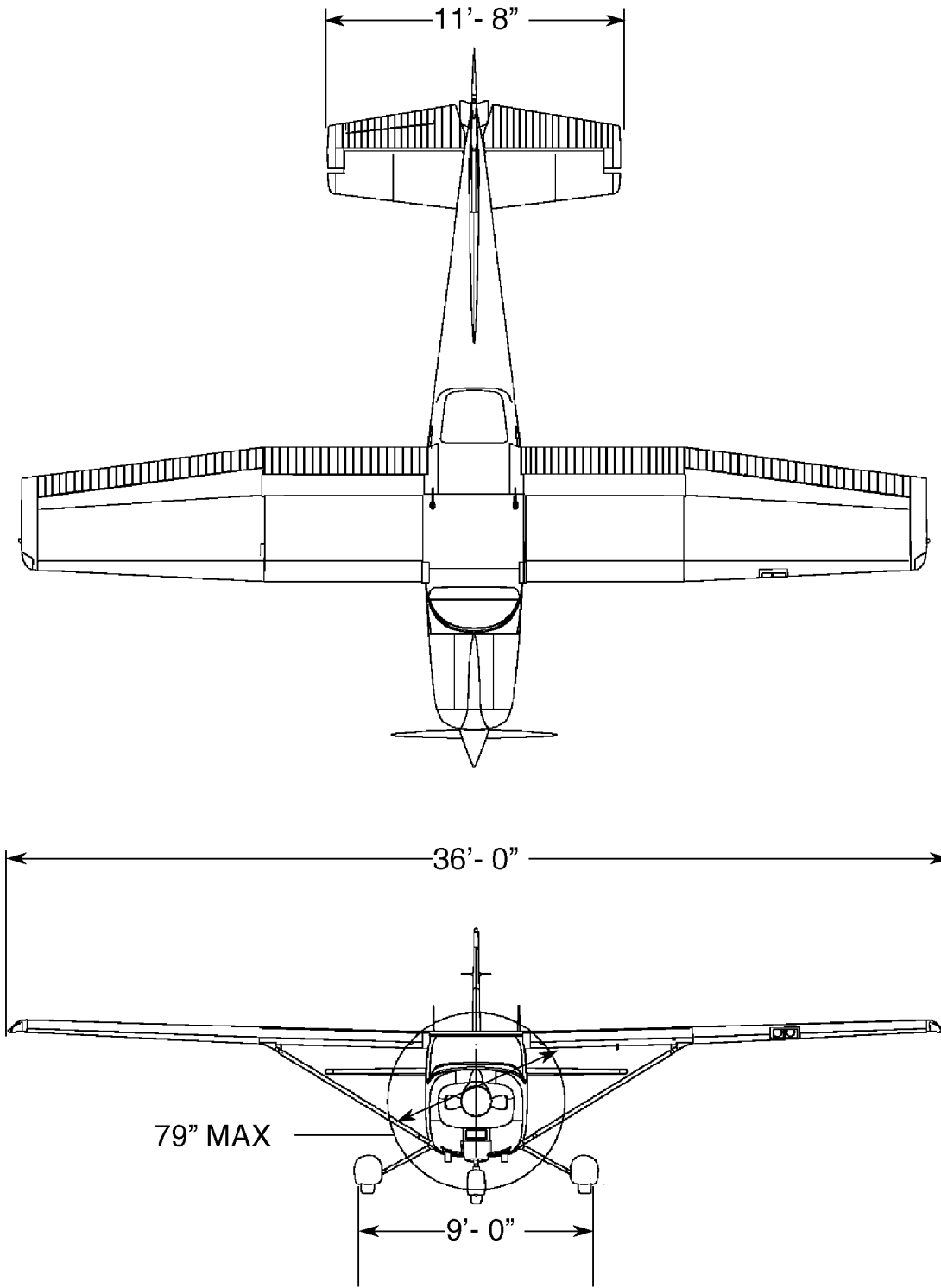

0785T1001

Figure 1-1 (Sheet 1 of 2)

THREE VIEW - NORMAL GROUND ATTITUDE

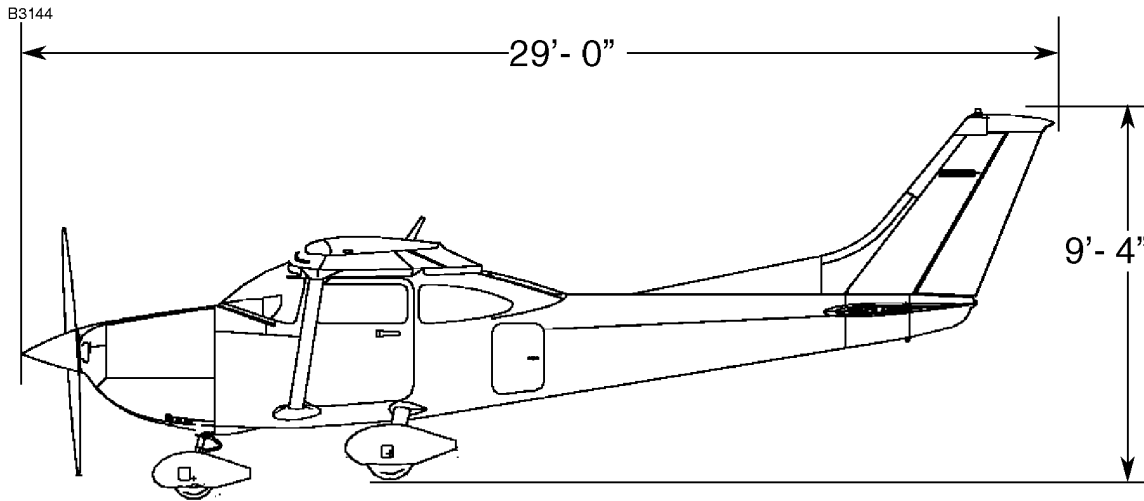

NOTE

- Wing span shown with standard strobe lights installed.
- Wheel base length is 66.5 inches.
- Propeller ground clearance is 10.875 inches.
- Wing area is 174.0 square feet.
- Minimum turning radius (*pivot point to outboard wing tip) is 27.0 feet.
- Normal ground attitude is shown with nose strut showing approximately 2 inches of strut, and wings level.

Figure 1-1 (Sheet 2)

INTRODUCTION

This POH contains 9 sections, and includes the material required to be furnished to the pilot by 14 CFR 23. It also contains supplemental data supplied by Cessna Aircraft Company.

Section 1 provides basic data and information of general interest. It also contains definitions or explanations of symbols, abbreviations, and terminology commonly used.

DESCRIPTIVE DATA

ENGINE

Number of Engines: 1

Engine Manufacturer: Textron Lycoming

Engine Model Number: IO-540-AB1A5

Engine Type: Normally aspirated, direct drive, air-cooled, horizontally opposed, fuel injected, six cylinder engine with 541.5 cu. in. displacement.

Horsepower Rating and Engine Speed: 230 rated BHP at 2400 RPM

PROPELLER

Propeller Manufacturer: McCauley Propeller Systems

Propeller Model Number: B3D36C431/80VSA-1

Number of Blades: 3

Propeller Diameter: 79 inches

Propeller Type: Constant speed and hydraulically actuated.

(Continued Next Page)

DESCRIPTIVE DATA (Continued)

FUEL

WARNING

USE OF UNAPPROVED FUELS MAY RESULT IN DAMAGE TO THE ENGINE AND FUEL SYSTEM COMPONENTS, RESULTING IN POSSIBLE ENGINE FAILURE.

Approved Fuel Grades (and Colors):

- 100LL Grade Aviation Fuel (Blue)
- 100 Grade Aviation Fuel (Green)

NOTE

Isopropyl alcohol or Diethylene Glycol Monomethyl Ether (DiEGME) may be added to the fuel supply. Additive concentrations shall not exceed 1% for isopropyl alcohol or 0.10% to 0.15% for DiEGME. Refer to Section 8 for additional information.

FUEL CAPACITY

Total Capacity92.0 U.S. GALLONS
Total Usable87.0 U.S. GALLONS
Total Capacity Each Tank46.0 U.S. GALLONS
Total Usable Each Tank43.5 U.S. GALLONS

NOTE

To ensure maximum fuel capacity and minimize crossfeeding when refueling, always park the airplane in a wings level, normal ground attitude and place the fuel selector in the LEFT or RIGHT position. Refer to Figure 1-1 for normal ground attitude dimensions.

(Continued Next Page)

DESCRIPTIVE DATA (Continued)

OIL

OIL SPECIFICATION

MIL-L-6082 or SAE J1966 Aviation Grade Straight Mineral Oil: Used when the airplane was delivered from the factory and should be used to replenish the supply during the first 25 hours. This oil should be drained and the filter changed after the first 25 hours of operation. Refill the engine with MIL-L-6082 or SAE J1966 Aviation Grade Straight Mineral Oil and continue to use until a total of 50 hours has accumulated or oil consumption has stabilized.

MIL-L-22851 or SAE J1899 Aviation Grade Ashless Dispersant Oil: Oil conforming to Textron Lycoming Service Instruction No 1014, and all revisions and supplements thereto, **must be used** after first 50 hours or oil consumption has stabilized.

Recommended viscosity for temperature range:

Temperature	MIL-L-6082 or SAE J1966 Straight Mineral Oil SAE Grade	MIL-L-22851 or SAE J1899 Ashless Dispersant Oil SAE Grade
Above 27°C (80°F)	60	60
Above 16°C (60°F)	50	40 or 50
-1°C (30°F) to 32°C (90°F)	40	40
-18°C (0°F) to 21°C (70°F)	30	30, 40 or 20W-40
Below -12°C (10°F)	20	30 or 20W-30
-18°C (0°F) to 32°C (90°F)	20W-50	20W-50 or 15W-50
All Temperatures	---	15W-50 or 20W-50

NOTE

When operating temperatures overlap, use the lighter grade of oil.

OIL CAPACITY

Sump 8 U.S. QUARTS
 Total 9 U.S. QUARTS

(Continued Next Page)

DESCRIPTIVE DATA (Continued)

MAXIMUM CERTIFICATED WEIGHTS

Ramp Weight	3110 POUNDS
Takeoff Weight	3100 POUNDS
Landing Weight	2950 POUNDS

WEIGHT IN BAGGAGE COMPARTMENT, NORMAL CATEGORY

Baggage Area A (Station 82 to 109).	120 POUNDS
.	Refer to note below.
Baggage Area B (Station 109 to 124).	80 POUNDS
.	Refer to note below
Baggage Area C (Station 124 to 134)	80 POUNDS
.	Refer to note below

NOTE

The maximum allowable combined weight capacity for baggage in areas A, B and C is 200 pounds. The maximum allowable weight capacity for baggage in areas B and C is 80 pounds.

STANDARD AIRPLANE WEIGHTS

Standard Empty Weight	1924 POUNDS
Maximum Useful Load, Normal Category	1186 POUNDS

CABIN AND ENTRY DIMENSIONS

Detailed dimensions of the cabin interior and entry door openings are illustrated in Section 6.

BAGGAGE SPACE AND ENTRY DIMENSIONS

Dimensions of the baggage area and baggage door opening are illustrated in detail in Section 6.

SPECIFIC LOADINGS

Wing Loading	17.8 lbs/sq. ft.
Power Loading	13.5 lbs/hp

SYMBOLS, ABBREVIATIONS AND TERMINOLOGY

GENERAL AIRSPEED TERMINOLOGY AND SYMBOLS

KCAS **Knots Calibrated Airspeed** is indicated airspeed corrected for position and instrument error and expressed in knots. Knots calibrated airspeed is equal to KTAS in standard atmosphere at sea level.

KIAS **Knots Indicated Airspeed** is the speed shown on the airspeed indicator and expressed in knots.

KTAS **Knots True Airspeed** is the airspeed expressed in knots relative to undisturbed air which is KCAS corrected for altitude and temperature.

V_A **Maneuvering Speed** is the maximum speed at which full or abrupt control movements may be used without overstressing the airframe.

V_{FE} **Maximum Flap Extended Speed** is the highest speed permissible with wing flaps in a prescribed extended position.

V_{NO} **Maximum Structural Cruising Speed** is the speed that should not be exceeded except in smooth air, then only with caution.

V_{NE} **Never Exceed Speed** is the speed limit that may not be exceeded at any time.

V_S **Stalling Speed or the minimum steady flight speed** is the minimum speed at which the airplane is controllable.

V_{SO} **Stalling Speed or the minimum steady flight speed** is the minimum speed at which the airplane is controllable in the landing configuration at the most forward center of gravity.

V_x **Best Angle of Climb Speed** is the speed which results in the greatest gain of altitude in a given horizontal distance.

V_y **Best Rate of Climb Speed** is the speed which results in the greatest gain in altitude in a given time.

(Continued Next Page)

SYMBOLS, ABBREVIATIONS AND TERMINOLOGY

(Continued)

METEOROLOGICAL TERMINOLOGY

OAT **Outside Air Temperature** is the free air static temperature. It may be expressed in either degrees Celsius or degrees Fahrenheit.

Standard Temperature **Standard Temperature** is 15°C at sea level pressure altitude and decreases by 2°C for each 1000 feet of altitude.

Pressure Altitude **Pressure Altitude** is the altitude read from an altimeter when the altimeter's barometric scale has been set to 29.92 inches of mercury (1013 mb).

ENGINE POWER TERMINOLOGY

BHP **Brake Horsepower** is the power developed by the engine.

RPM **Revolutions Per Minute** is engine speed.

Static RPM **Static RPM** is engine speed attained during a full throttle engine runup when the airplane is on the ground and stationary.

MP **Manifold Pressure** is a pressure measured in the engine's induction system and is expressed in inches of mercury (in.hg.).

MCP **Maximum Continuous Power**

(Continued Next Page)

SYMBOLS, ABBREVIATIONS AND TERMINOLOGY

(Continued)

ENGINE POWER TERMINOLOGY (Continued)

Lean Mixture	Decreased proportion of fuel in the fuel-air mixture supplied to the engine. As air density decreases, the amount of fuel required by the engine decreases for a given throttle setting. Adjusting the fuel-air mixture to provide a smaller portion of fuel is known as "leaning" the mixture.
Rich Mixture	Increased proportion of fuel in the fuel-air mixture supplied to the engine. As air density increases, the amount of fuel required by the engine increases for a given throttle setting. Adjusting the fuel-air mixture to provide a greater portion of fuel is known as "richening" the mixture.
Full Rich	Mixture control full forward (pushed in, full control travel, toward the panel).
Idle Cutoff	Mixture control full aft (pulled out, full control travel, away from the panel).
Full Throttle	Throttle full forward (pushed in, full control travel, toward the panel). Also known as "full open" throttle.
Closed Throttle	Throttle full aft (pulled out, full control travel, away from the panel). Also known as the throttle "idle" position.

(Continued Next Page)

SYMBOLS, ABBREVIATIONS AND TERMINOLOGY

(Continued)

AIRPLANE PERFORMANCE AND FLIGHT PLANNING TERMINOLOGY

Demonstrated
Crosswind
Velocity

Demonstrated Crosswind Velocity is the velocity of the crosswind component for which adequate control of the airplane during takeoff and landing was actually demonstrated during certification tests. The value shown is not considered to be limiting.

Usable Fuel **Usable Fuel** is the fuel available for flight planning.

Unusable Fuel **Unusable Fuel** is the quantity of fuel that can not be safely used in flight.

GPH **Gallons Per Hour** is the amount of fuel consumed per hour.

NMPG **Nautical Miles Per Gallon** is the distance which can be expected per gallon of fuel consumed at a specific engine power setting and/or flight configuration.

g **g** is acceleration due to gravity.

Course Datum **Course Datum** is the compass reference used by the autopilot, along with course deviation, to provide lateral control when tracking a navigation signal.

(Continued Next Page)

SYMBOLS, ABBREVIATIONS AND TERMINOLOGY

(Continued)

WEIGHT AND BALANCE TERMINOLOGY

Reference
Datum

Reference Datum is an imaginary vertical plane from which all horizontal distances are measured for balance purposes.

Station

Station is a location along the airplane fuselage given in terms of the distance from the reference datum.

Arm

Arm is the horizontal distance from the reference datum to the center of gravity (C.G.) of an item.

Moment

Moment is the product of the weight of an item multiplied by its arm. (Moment divided by the constant 1000 is used in this POH to simplify balance calculations by reducing the number of digits.)

Center of
Gravity (C.G.)

Center of Gravity is the point at which an airplane, or equipment, would balance if suspended. Its distance from the reference datum is found by dividing the total moment by the total weight of the airplane.

C.G. Arm

Center of Gravity Arm is the arm obtained by adding the airplane's individual moments and dividing the sum by the total weight.

C.G. Limits

Center of Gravity Limits are the extreme center of gravity locations within which the airplane must be operated at a given weight.

Standard
Empty Weight

Standard Empty Weight is the weight of a standard airplane, including unusable fuel, full operating fluids and full engine oil.

(Continued Next Page)

SYMBOLS, ABBREVIATIONS AND TERMINOLOGY (Continued)

WEIGHT AND BALANCE TERMINOLOGY (Continued)

Basic Empty Weight	Basic Empty Weight is the standard empty weight plus the weight of optional equipment.
Useful Load	Useful Load is the difference between ramp weight and the basic empty weight.
MAC	MAC (Mean Aerodynamic Chord) is a chord of an imaginary rectangular airfoil having the same pitching moments throughout the flight range as that of the actual wing.
Maximum Ramp Weight	Maximum Ramp Weight is the maximum weight approved for ground maneuver, and includes the weight of fuel used for start, taxi and runup.
Maximum Takeoff Weight	Maximum Takeoff Weight is the maximum weight approved for the start of the takeoff roll.
Maximum Landing Weight	Maximum Landing Weight is the maximum weight approved for the landing touchdown.
Tare	Tare is the weight of chocks, blocks, stands, etc. used when weighing an airplane, and is included in the scale readings. Tare is deducted from the scale reading to obtain the actual (net) airplane weight.

METRIC/IMPERIAL/U.S. CONVERSION CHARTS

The following charts have been provided to help international operators convert U.S. measurement supplied with the Pilot's Operating Handbook into metric and imperial measurements.

The standard followed for measurement units shown is the National Institute of Standards Technology (NIST), Publication 811, "Guide for the Use of the International System of Units (SI)."

Please refer to the following pages for these charts.

WEIGHT CONVERSIONS

B5719

(Kilograms x 2.205 = Pounds) (Pounds x .454 = Kilograms)

Kilograms into Pounds Kilogrammes en Livres

kg	0	1	2	3	4	5	6	7	8	9
	lb.	lb.	lb.	lb.	lb.	lb.	lb.	lb.	lb.	lb.
0	---	2.205	4.409	6.614	8.819	11.023	13.228	15.432	17.637	19.842
10	22.046	24.251	26.456	28.660	30.865	33.069	35.274	37.479	39.683	41.888
20	44.093	46.297	48.502	50.706	52.911	55.116	57.320	59.525	61.729	63.934
30	66.139	68.343	70.548	72.753	74.957	77.162	79.366	81.571	83.776	85.980
40	88.185	90.390	92.594	94.799	97.003	99.208	101.41	103.62	105.82	108.03
50	110.23	112.44	114.64	116.85	119.05	121.25	123.46	125.66	127.87	130.07
60	132.28	134.48	136.69	138.89	141.10	143.30	145.51	147.71	149.91	152.12
70	154.32	156.53	158.73	160.94	163.14	165.35	167.55	169.76	171.96	174.17
80	176.37	178.57	180.78	182.98	185.19	187.39	189.60	191.80	194.01	196.21
90	198.42	200.62	202.83	205.03	207.24	209.44	211.64	213.85	216.05	218.26
100	220.46	222.67	224.87	227.08	229.28	231.49	233.69	235.90	238.10	240.30

Pounds into Kilograms Livres en Kilogrammes

lb.	0	1	2	3	4	5	6	7	8	9
	kg	kg	kg	kg	kg	kg	kg	kg	kg	kg
0	---	0.454	0.907	1.361	1.814	2.268	2.722	3.175	3.629	4.082
10	4.536	4.990	5.443	5.897	6.350	6.804	7.257	7.711	8.165	8.618
20	9.072	9.525	9.979	10.433	10.886	11.340	11.793	12.247	12.701	13.154
30	13.608	14.061	14.515	14.969	15.422	15.876	16.329	16.783	17.237	17.690
40	18.144	18.597	19.051	19.504	19.958	20.412	20.865	21.319	21.772	22.226
50	22.680	23.133	23.587	24.040	24.494	24.948	25.401	25.855	26.303	26.762
60	27.216	27.669	28.123	28.576	29.030	29.484	29.937	30.391	30.844	31.298
70	31.752	32.205	32.659	33.112	33.566	34.019	34.473	34.927	35.380	35.834
80	36.287	36.741	37.195	37.648	38.102	38.555	39.009	39.463	39.916	40.370
90	40.823	41.277	41.731	42.184	42.638	43.091	43.545	43.999	44.452	44.906
100	45.359	45.813	46.266	46.720	47.174	47.627	48.081	48.534	48.988	49.442

Figure 1-2 (Sheet 1 of 2)

WEIGHT CONVERSIONS

B3081

(Kilograms x 2.205 = Pounds)

(Pounds x .454 = Kilograms)

POUNDS

KILOGRAMS

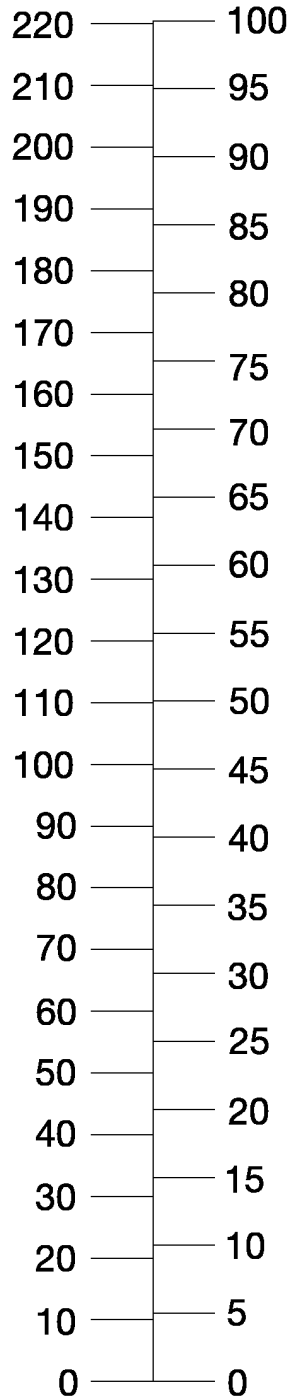

Units x 10, 100, etc.

0585T1027

Figure 1-2 (Sheet 2)

LENGTH CONVERSIONS

B5720

(Meters x 3.281 = Feet) (Feet x .305 = Meters)

Meters into Feet Metres en Pieds

m	0	1	2	3	4	5	6	7	8	9
	feet	feet	feet	feet	feet	feet	feet	feet	feet	feet
0	---	3.281	6.562	9.842	13.123	16.404	19.685	22.956	26.247	29.528
10	32.808	36.089	39.370	42.651	45.932	49.212	52.493	55.774	59.055	62.336
20	65.617	68.897	72.178	75.459	78.740	82.021	85.302	88.582	91.863	95.144
30	98.425	101.71	104.99	108.27	111.55	114.83	118.11	121.39	124.67	127.95
40	131.23	134.51	137.79	141.08	144.36	147.64	150.92	154.20	157.48	160.76
50	164.04	167.32	170.60	173.86	177.16	180.45	183.73	187.01	190.29	193.57
60	195.85	200.13	203.41	206.69	209.97	213.25	216.53	219.82	223.10	226.38
70	229.66	232.94	236.22	239.50	242.78	246.06	249.34	252.62	255.90	259.19
80	262.47	265.75	269.03	272.31	275.59	278.87	282.15	285.43	288.71	291.58
90	295.27	298.56	301.84	305.12	308.40	311.68	314.96	318.24	321.52	324.80
100	328.08	331.36	334.64	337.93	341.21	344.49	347.77	351.05	354.33	357.61

Feet into Meters Pieds en Metres

ft	0	1	2	3	4	5	6	7	8	9
	m	m	m	m	m	m	m	m	m	m
0	---	0.305	0.610	0.914	1.219	1.524	1.829	2.134	2.438	2.743
10	3.048	3.353	3.658	3.962	4.267	4.572	4.877	5.182	5.486	5.791
20	6.096	6.401	6.706	7.010	7.315	7.620	7.925	8.230	8.534	8.839
30	9.144	9.449	9.754	10.058	10.363	10.668	10.973	11.278	11.582	11.887
40	12.192	12.497	12.802	13.106	13.411	13.716	14.021	14.326	14.630	14.935
50	15.240	15.545	15.850	16.154	16.459	16.754	17.069	17.374	17.678	17.983
60	18.288	18.593	18.898	19.202	19.507	19.812	20.117	20.422	20.726	21.031
70	21.336	21.641	21.946	22.250	22.555	22.860	23.165	23.470	23.774	24.079
80	24.384	24.689	24.994	25.298	25.603	25.908	26.213	26.518	26.822	27.127
90	27.432	27.737	28.042	28.346	28.651	28.956	29.261	29.566	29.870	30.175
100	30.480	30.785	31.090	31.394	31.699	32.004	32.309	32.614	32.918	33.223

Figure 1-3 (Sheet 1 of 4)

LENGTH CONVERSIONS

B3082

(Meters x 3.281 = Feet)

(Feet x .305 = Meters)

FEET METERS

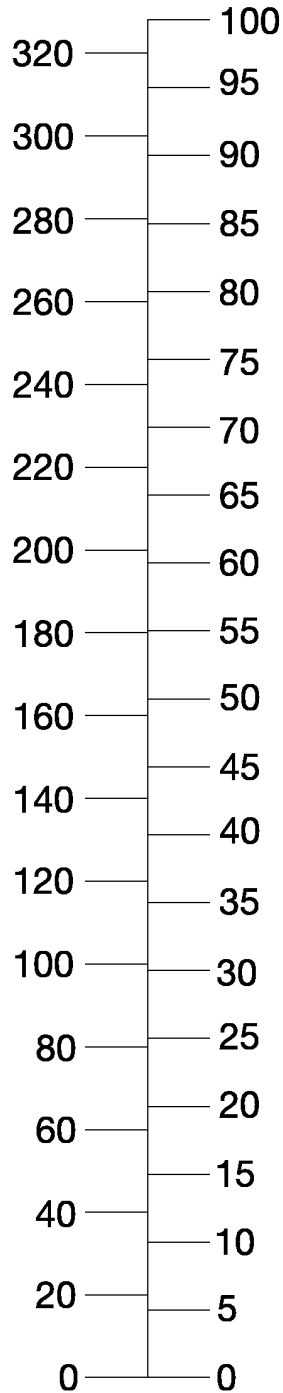

Units x 10, 100, etc.

0585T1027

Figure 1-3 (Sheet 2)

LENGTH CONVERSIONS

B5721

(Centimeters x .394 = Inches) (Inches x 2.54 = Centimeters)

Centimeters into Inches Centimetres en Pouces

cm	0	1	2	3	4	5	6	7	8	9
	in.	in.	in.	in.	in.	in.	in.	in.	in.	in.
0	---	0.394	0.787	1.181	1.575	1.969	2.362	2.756	3.150	3.543
10	3.937	4.331	4.724	5.118	5.512	5.906	6.299	6.693	7.087	7.480
20	7.874	8.268	8.661	9.055	9.449	9.843	10.236	10.630	11.024	11.417
30	11.811	12.205	12.598	12.992	13.386	13.780	14.173	14.567	14.961	15.354
40	15.748	16.142	16.535	16.929	17.323	17.717	18.110	18.504	18.898	19.291
50	19.685	20.079	20.472	20.866	21.260	21.654	22.047	22.441	22.835	23.228
60	23.622	24.016	24.409	24.803	25.197	25.591	25.984	26.378	26.772	27.164
70	27.559	27.953	28.346	28.740	29.134	29.528	29.921	30.315	30.709	31.102
80	31.496	31.890	32.283	32.677	33.071	33.465	33.858	34.252	34.646	35.039
90	35.433	35.827	36.220	36.614	37.008	37.402	37.795	38.189	38.583	38.976
100	39.370	39.764	40.157	40.551	40.945	41.339	41.732	42.126	42.520	42.913

Inches into Centimeters Pouces en Centimetres

in.	0	1	2	3	4	5	6	7	8	9
	cm	cm	cm	cm	cm	cm	cm	cm	cm	cm
0	---	2.54	5.08	7.62	10.16	12.70	15.24	17.78	20.32	22.86
10	25.40	27.94	30.48	33.02	35.56	38.10	40.64	43.18	45.72	48.26
20	50.80	53.34	55.88	58.42	60.96	63.50	66.04	68.58	71.12	73.66
30	76.20	78.74	81.28	83.82	86.36	88.90	91.44	93.98	96.52	99.06
40	101.60	104.14	106.68	109.22	111.76	114.30	116.84	119.38	121.92	124.46
50	127.00	129.54	132.08	134.62	137.16	139.70	142.24	144.78	147.32	149.86
60	152.40	154.94	157.48	160.02	162.56	165.10	167.64	170.18	172.72	175.26
70	177.80	180.34	182.88	185.42	187.96	190.50	193.04	195.58	198.12	200.66
80	203.20	205.74	208.28	210.82	213.36	215.90	218.44	220.98	223.52	226.06
90	228.60	231.14	233.68	236.22	238.76	241.30	243.84	246.38	248.92	251.46
100	254.00	256.54	259.08	261.62	264.16	266.70	269.24	271.78	274.32	276.86

Figure 1-3 (Sheet 3)

LENGTH CONVERSIONS

B3083

(Centimeters x .394 = Inches)

(Inches x 2.54 = Centimeters)

INCHES

CENTIMETERS

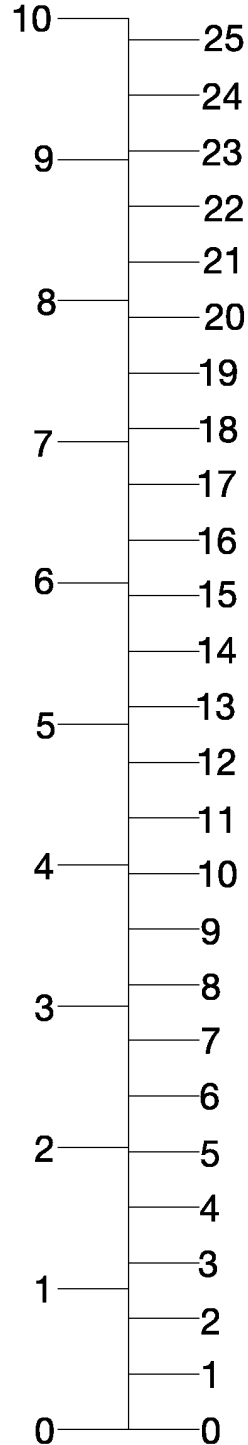

Units x 10, 100, etc.

0585T1028

Figure 1-3 (Sheet 4)

DISTANCE CONVERSIONS

B3084

(Statute Miles x 1.609 = Kilometers) (Kilometers x .622 = Statute Miles)
 (Statute Miles x .869 = Nautical Miles) (Nautical Miles x 1.15 = Statute Miles)
 (Nautical Miles x 1.852 = Kilometers) (Kilometers x .54 = Nautical Miles)

STATUTE
MILES

NAUTICAL
MILES

KILOMETERS

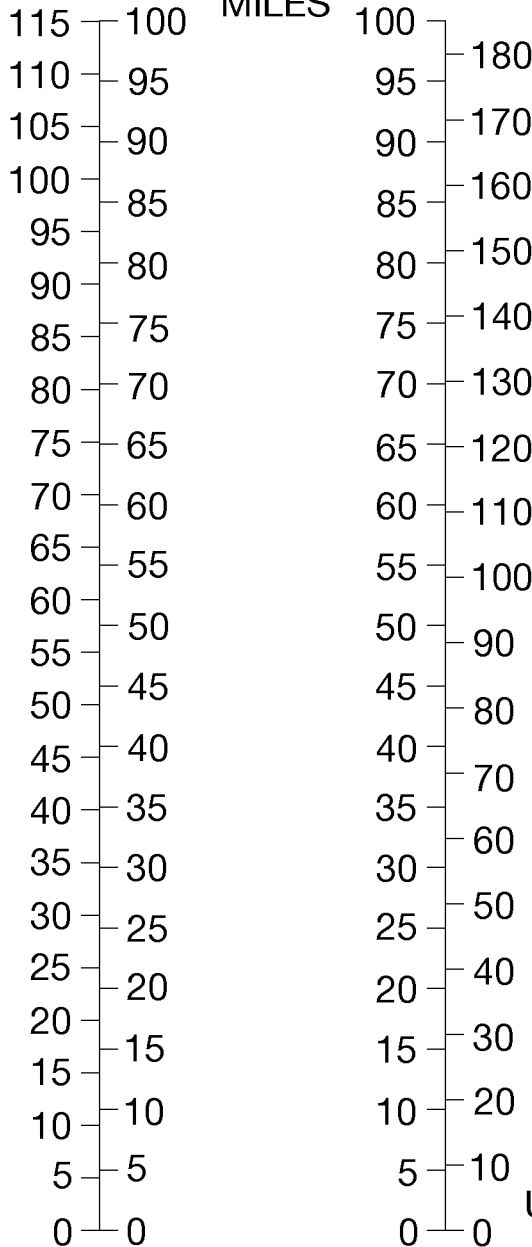

Units x 10, 100, etc.

0585T1029

Figure 1-4

VOLUME CONVERSIONS

B5722

(Imperial Gallons x 4.546 = Liters) (Liters x .22 = Imperial Gallons)

Liters into Imperial Gallons Litres en Gallons Imperial

Lt	0	1	2	3	4	5	6	7	8	9
	IG	IG	IG	IG	IG	IG	IG	IG	IG	IG
0	---	0.220	0.440	0.660	0.880	1.100	1.320	1.540	1.760	1.980
10	2.200	2.420	2.640	2.860	3.080	3.300	3.520	3.740	3.960	4.180
20	4.400	4.620	4.840	5.059	5.279	5.499	5.719	5.939	6.159	6.379
30	6.599	6.819	7.039	7.259	7.479	7.699	7.919	8.139	8.359	8.579
40	8.799	9.019	9.239	9.459	9.679	9.899	10.119	10.339	10.559	10.779
50	10.999	11.219	11.439	11.659	11.879	12.099	12.319	12.539	12.759	12.979
60	13.199	13.419	13.639	13.859	14.078	14.298	14.518	14.738	14.958	15.178
70	15.398	15.618	15.838	16.058	16.278	16.498	16.718	16.938	17.158	17.378
80	17.598	17.818	18.038	18.258	18.478	18.698	18.918	19.138	19.358	19.578
90	19.798	20.018	20.238	20.458	20.678	20.898	21.118	21.338	21.558	21.778
100	21.998	22.218	22.438	22.658	22.878	23.098	23.318	23.537	23.757	23.977

Imperial Gallons into Liters Gallons Imperial en Litres

IG	0	1	2	3	4	5	6	7	8	9
	Lt	Lt	Lt	Lt	Lt	Lt	Lt	Lt	Lt	Lt
0	---	4.546	9.092	13.638	18.184	22.730	27.276	31.822	36.368	40.914
10	45.460	50.006	54.552	59.097	63.643	68.189	72.735	77.281	81.827	86.373
20	90.919	95.465	100.01	104.56	109.10	113.65	118.20	122.74	127.29	131.83
30	136.38	140.93	145.47	150.02	154.56	159.11	163.66	168.20	172.75	177.29
40	181.84	186.38	190.93	195.48	200.02	204.57	209.11	213.66	218.21	222.75
50	227.30	231.84	236.39	240.94	245.48	250.03	254.57	259.12	263.67	268.21
60	272.76	277.30	281.85	286.40	290.94	295.49	300.03	304.58	309.13	313.67
70	318.22	322.76	327.31	331.86	336.40	340.95	345.49	350.04	354.59	359.13
80	363.68	368.22	372.77	377.32	381.86	386.41	390.95	395.50	400.04	404.59
90	409.14	413.68	418.23	422.77	427.32	431.87	436.41	440.96	445.50	450.05
100	454.60	459.14	463.69	468.23	472.78	477.33	481.87	486.42	490.96	495.51

Figure 1-5 (Sheet 1 of 3)

VOLUME CONVERSIONS

B3085

(Imperial Gallons X 4.546 = Liters)
(Liters X .22 = Imperial Gallons)

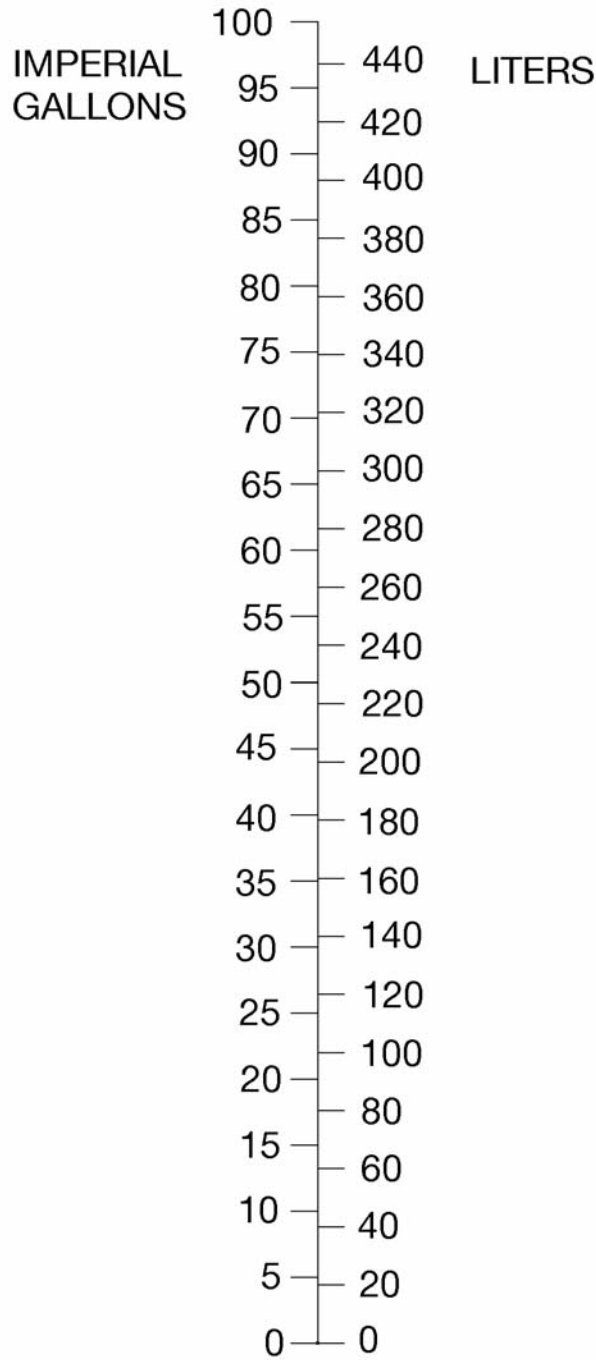

Units x 10, 100, etc.

0585T1032

Figure 1-5 (Sheet 2)

VOLUME CONVERSIONS

B3086

(Imperial Gallons x 1.2 = U.S. Gallons)
 (U.S. Gallons x .883 = Imperial Gallons)
 (U.S. Gallons x 3.785 = Liters)
 (Liters x .264 = U.S. Gallons)

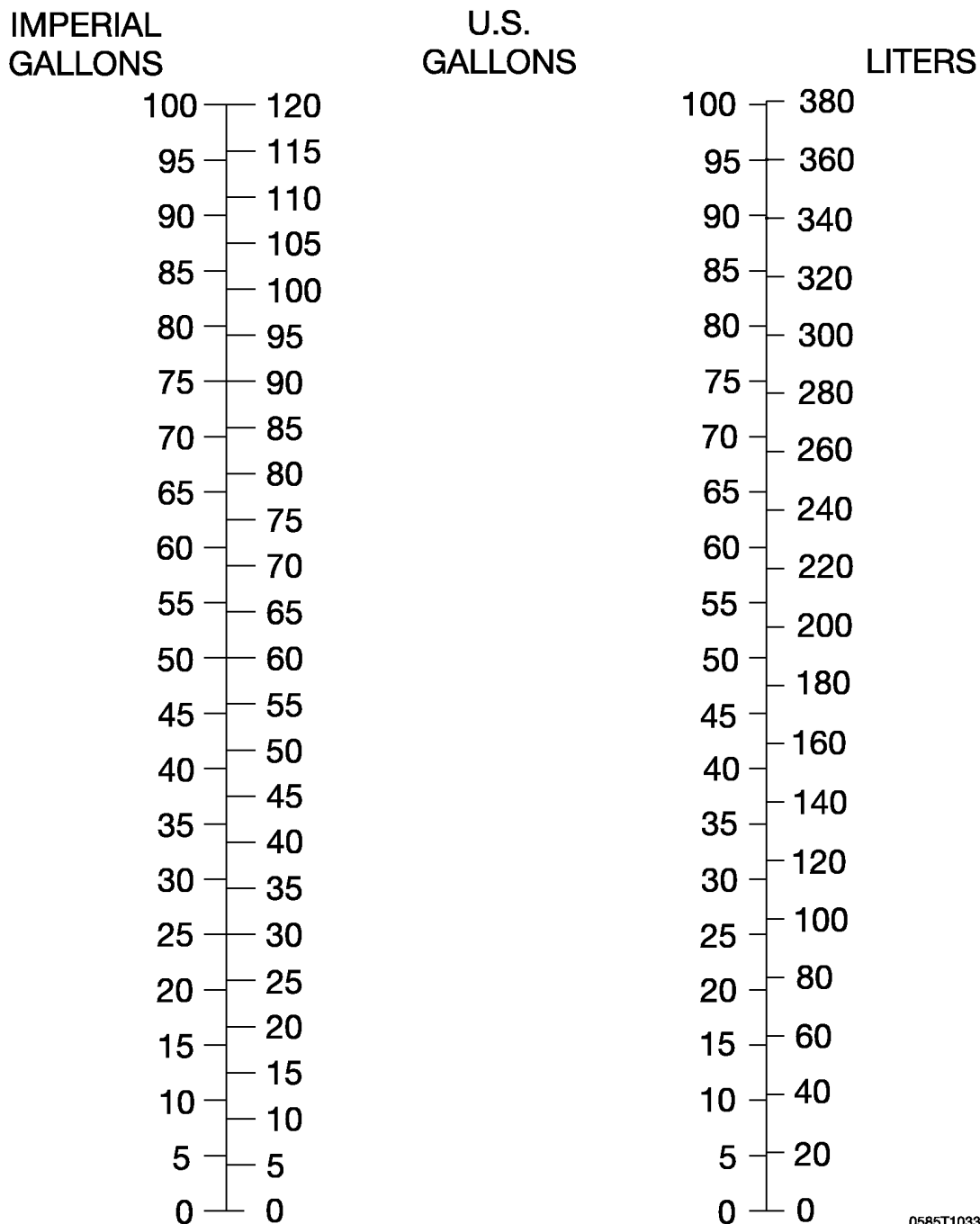

0585T1033

Figure 1-5 (Sheet 3)

TEMPERATURE CONVERSIONS

B3087

$$(^{\circ}\text{F} - 32) \times 5/9 = ^{\circ}\text{C} \quad ^{\circ}\text{C} \times 9/5 + 32 = ^{\circ}\text{F}$$

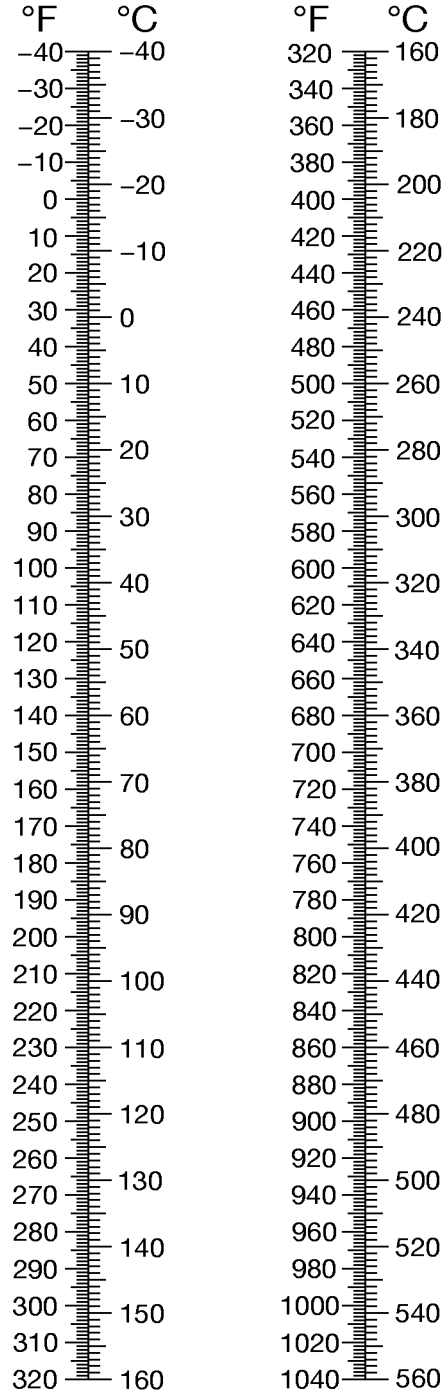

0585T1034

Figure 1-6

PRESSURE CONVERSION

HECTOPASCALS TO INCHES OF MERCURY

B3995

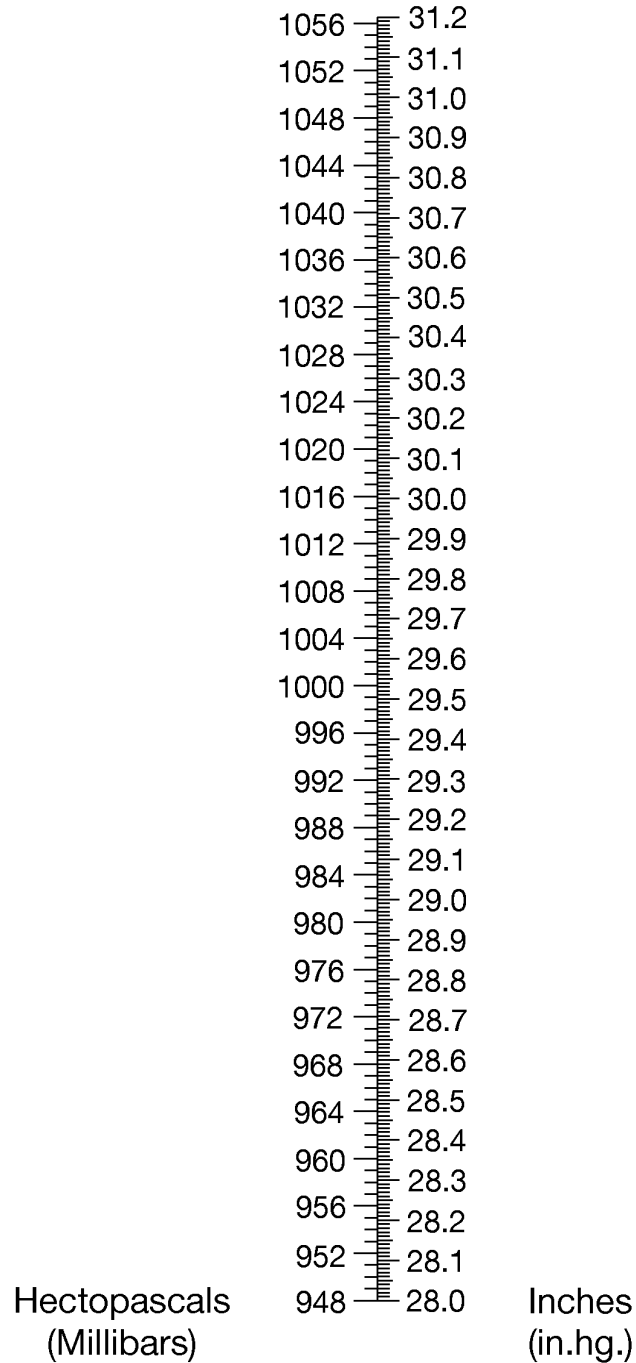

Figure 1-7

VOLUME TO WEIGHT CONVERSION

B3088

AVGAS Specific Gravity = .72

(Liters x .72 = Kilograms)
(Liters x 1.58 = Pounds)

(Kilograms x 1.389 = Liters)
(Pounds x .633 = Liters)

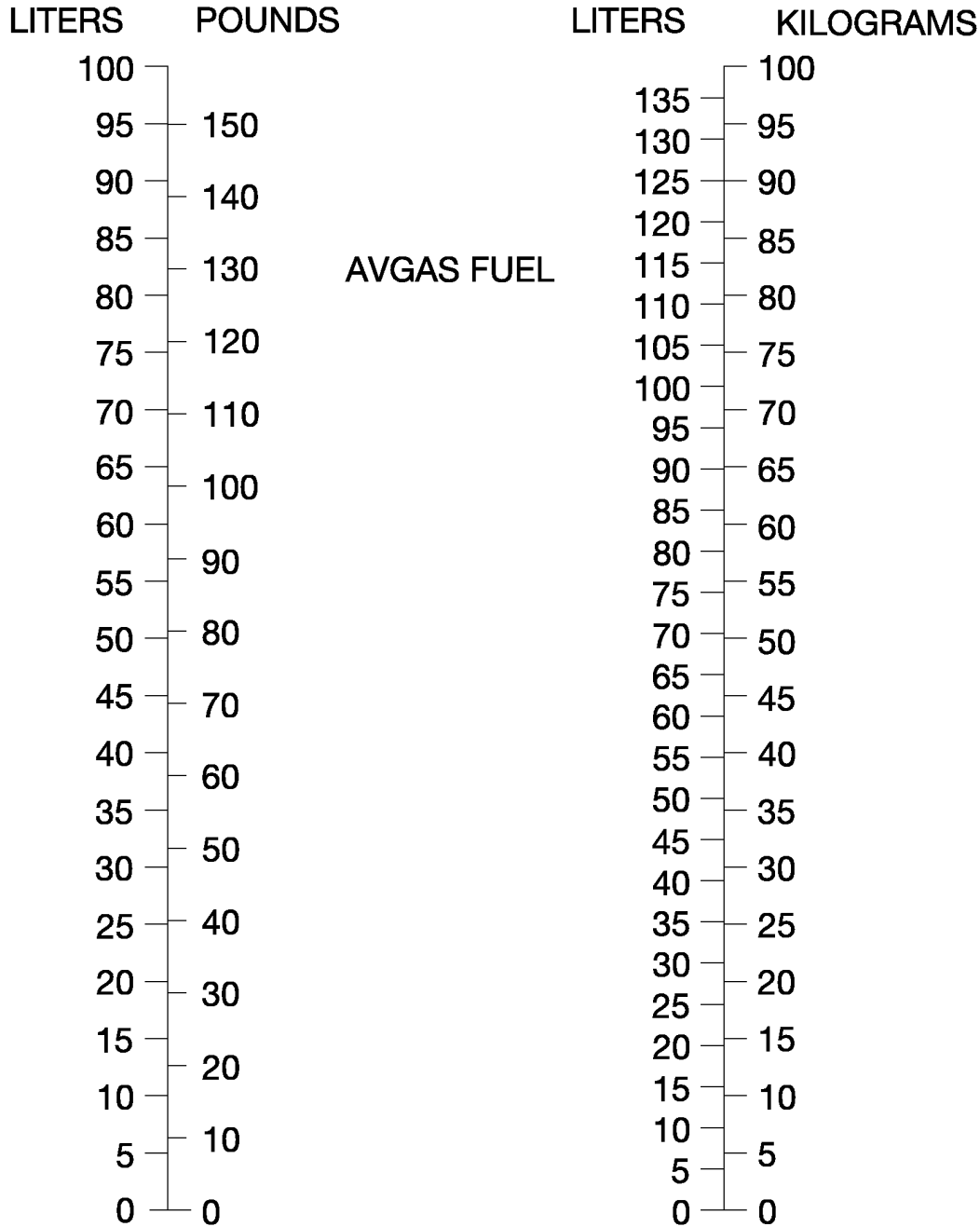

Units x 10, 100, etc.

0585T1030

Figure 1-8

QUICK CONVERSIONS

B3089

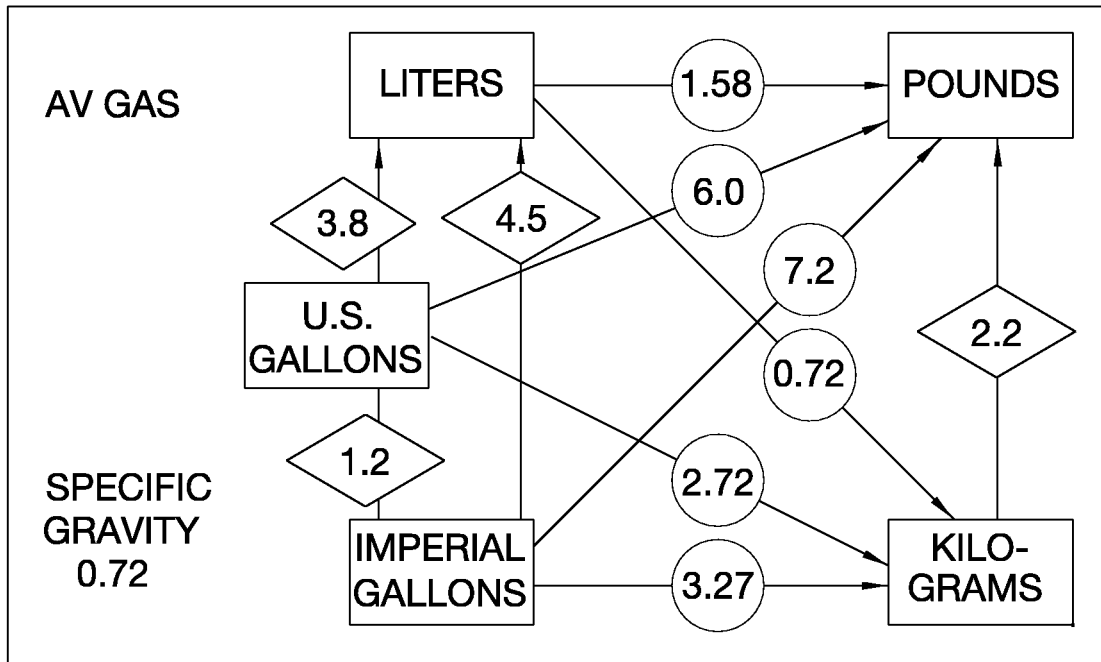

0585T1031

Figure 1-9

OPERATING LIMITATIONS

TABLE OF CONTENTS

	Page
Introduction	2-3
Airspeed Limitations	2-4
Airspeed Indicator Markings	2-5
Powerplant Limitations.	2-6
Powerplant Instrument Markings	2-7
Weight Limits	2-8
Center Of Gravity Limits.	2-8
Maneuver Limits	2-9
Flight Load Factor Limits	2-9
Kinds Of Operations Limits	2-9
Kinds Of Operations Equipment List	2-10
Fuel Limitations	2-15
■ Flap Limitations	2-15
System Limitations.	2-16
Aux Audio System.	2-16
12V Power System	2-16
G1000 Limitations	2-17
GPS - WAAS.	2-18
■ Garmin GFC 700 AFCS	2-19
L3 Communications WX-500 Stormscope	2-19
Traffic Advisory System (TAS).	2-20
Terrain Awareness and Warning System (TAWS-B)	2-20
Placards.	2-21

INTRODUCTION

Section 2 includes operating limitations, instrument markings, and basic placards necessary for the safe operation of the airplane, its engine, standard systems and standard equipment. The limitations included in this section and in Section 9 have been approved by the Federal Aviation Administration. Observance of these operating limitations is required by Federal Aviation Regulations.

NOTE

- Refer to Supplements, Section 9 of this Pilot's Operating Handbook for amended operating limitations, operating procedures, performance data and other necessary information for airplanes equipped with specific options.
- The airspeeds listed in Figure 2-1, Airspeed Limitations, and Figure 2-2, Airspeed Indicator Markings, are based on Airspeed Calibration data shown in Section 5 with the normal static source. If the alternate static source is being used, ample margins should be observed to allow for the airspeed calibration variations between the normal and alternate static sources as shown in Section 5.

The Cessna Model No. 182T is certificated under FAA Type Certificate No. 3A13.

AIRSPEED LIMITATIONS

Airspeed limitations and their operational significance are shown in Figure 2-1.

AIRSPEED LIMITATIONS

SYMBOL	SPEED	KCAS	KIAS	REMARKS
V _{NE}	Never Exceed Speed	171	175	Do not exceed this speed in any operation.
V _{NO}	Maximum Structural Cruising Speed	136	140	Do not exceed this speed except in smooth air, and then only with caution.
V _A	Maneuvering Speed: 3100 Pounds 2600 Pounds 2100 Pounds	108 100 91	110 101 91	Do not make full or abrupt control movements above this speed.
V _{FE}	Maximum Flap Extended Speed: FLAPS UP to 10° FLAPS 10° to 20° FLAPS 20° to FULL°	136 117 99	140 120 100	Do not exceed this speed with flaps down.
-----	Maximum Window Open Speed	171	175	Do not exceed this speed with windows open.

Figure 2-1

AIRSPEED INDICATOR MARKINGS

Airspeed indicator markings and their color code significance are shown in Figure 2-2.

AIRSPEED INDICATOR MARKINGS

MARKING	KIAS VALUE OR RANGE	SIGNIFICANCE
Red Arc*	20 - 41	Low airspeed warning.
White Arc	41 -100	Full Flap Operating Range. Lower limit is maximum weight V_{SO} in landing configuration. Upper limit is maximum speed permissible with flaps extended.
Green Arc	51 - 140	Normal Operating Range. Lower limit is maximum weight V_S at most forward C.G. with flaps retracted. Upper limit is maximum structural cruising speed.
Yellow Arc	140 - 175	Operations must be conducted with caution and only in smooth air.
Red Line	175	Maximum speed for all operations.

*G1000 airspeed indicator only.

Figure 2-2

POWERPLANT LIMITATIONS

Engine Manufacturer: Textron Lycoming

Engine Model Number: IO-540-AB1A5

Engine Operating Limits for Takeoff and Continuous Operations:

Maximum Continuous Power: 230 rated BHP at 2400 RPM
Maximum Cylinder Head Temperature: 500°F (260°C)
Maximum Oil Temperature: 245°F (118°C)
Oil Pressure, Minimum: 20 PSI
Oil Pressure, Maximum: 115 PSI

CAUTION

ENGINE OPERATION WITH INDICATED OIL PRESSURE BELOW THE GREEN BAND RANGE WHILE IN CRUISE OR CLIMB CONFIGURATION IS CONSIDERED ABNORMAL AND SHOULD BE INSPECTED BY QUALIFIED MAINTENANCE PERSONNEL BEFORE NEXT FLIGHT.

Fuel Grade: Refer to Fuel Limitations

Oil Grade (Specification):

MIL-L-6082 or SAE J1966 Aviation Grade Straight Mineral Oil or MIL-L-22851 or SAE J1899 Ashless Dispersant Oil. Oil must comply with the latest revision and/or supplement for Textron Lycoming Service Instruction No. 1014, **must be used**.

Propeller Manufacturer: McCauley Propeller Systems

Propeller Model Number: B3D36C431/80VSA-1

Propeller Diameter:

Maximum 79.0 INCHES
Minimum 77.5 INCHES

POWERPLANT INSTRUMENT MARKINGS

Powerplant instrument markings and their color code significance are shown in Figure 2-3. Operation with indications in the red range is prohibited. Avoid operating with indicators in the yellow range.

POWERPLANT INSTRUMENT MARKINGS

INSTRUMENT	RED LINE (MIN)	RED ARC (LWR)	YELLOW ARC	GREEN ARC (NORMAL OPERATING RANGE)	RED ARC (UPR)	RED LINE (MAX)
Tachometer	----	----	----	2000 to 2400 RPM	2400* to 2700 RPM	---
Manifold Pressure	---	---	---	15 to 23 in.hg.	---	---
Cylinder Head Temperature	----	----	----	200 to 500°F	----	500°F
Oil Temperature	----	----	----	100 to 245°F	245* to 250°F	---
Oil Pressure	----	0 to 20 PSI	----	50 to 90 PSI	115* to 120 PSI	---
Fuel Quantity	0 (2.5 Gallons Unusable Each Tank)	----	0 to 8 Gallons	8 to 35 Gallons	----	---
Fuel Flow	----	----	----	0 to 18 GPH 24 GPH	----	---
Vacuum Gage	----	----	----	4.5 to 5.5 in.hg.	----	---

*Maximum operating limit is lower end of red arc.

Figure 2-3

WEIGHT LIMITS

Maximum Ramp Weight: 3110 POUNDS
Maximum Takeoff Weight: 3100 POUNDS
Maximum Landing Weight: 2950 POUNDS

Maximum Weight in Baggage Compartment:

Baggage Area A - Station 82 to 109: 120 POUNDS
..... Refer to note below.
Baggage Area B - Station 109 to 124: 80 POUNDS
..... Refer to note below.
Baggage Area C - Station 124 to 134: 80 POUNDS
..... Refer to note below.

NOTE

The maximum allowable combined weight capacity for baggage in areas A, B and C is 200 pounds. The maximum combined allowable weight capacity for baggage in areas B and C is 80 pounds.

CENTER OF GRAVITY LIMITS

Center of Gravity Range:

Forward: 33.0 inches aft of datum at 2250 pounds or less, with straight line variation to 35.5 inches aft of datum at 2700 pounds or less, with straight line variation to 40.9 inches aft of datum at 3100 pounds, continuing to aft limit at 3100 pounds.

Aft: 46.0 inches aft of datum at all weights.

Reference Datum: Front face of firewall

MANEUVER LIMITS

This airplane is certificated in the normal category. The normal category is applicable to aircraft intended for non aerobatic operations. These include any maneuvers incidental to normal flying, stalls (except whip stalls), lazy eights, chandelles, and turns in which the angle of bank is not more than 60°.

Aerobatic maneuvers, including spins, are not approved.

FLIGHT LOAD FACTOR LIMITS

Flight Load Factors (Maximum Takeoff Weight - 3100 POUNDS):

- *Flaps UP:+3.8g, -1.52g
- *Flaps FULL:+2.0g

* The design load factors are 150% of the above, and in all cases, the structure meets or exceeds design loads.

KINDS OF OPERATIONS LIMITS

The Cessna 182T Nav III airplane is approved for day and night, VFR and IFR operations. Flight into known icing conditions is prohibited.

The minimum equipment for approved operations required under the Operating Rules are defined by 14 CFR 91 and 14 CFR 135, as applicable.

The following Kinds of Operations Equipment List (KOEL) identifies the equipment required to be operational for airplane airworthiness in the listed kind of operations.

█

KINDS OF OPERATIONS EQUIPMENT LIST

System, Instrument, Equipment and/or Function	KIND OF OPERATION				COMMENTS
	VFR DAY	VFR NIGHT	IFR DAY	IFR NIGHT	
PLACARDS AND MARKINGS					
182T Nav III - GFC 700 AFCS POH/AFM	1	1	1	1	Accessible to pilot in flight.
Garmin G1000 Cockpit Reference Guide	1	1	1	1	Accessible to pilot in flight.
AIR CONDITIONING					
1 - Forward Avionics Fan	1	1	1	1	
2 - PFD Fan	0	0	0	0	
3 - MFD Fan	0	0	0	0	
4 - Aft Avionics Fan	1	1	1	1	
COMMUNICATIONS					
1 - VHF COM	0	0	1	1	
ELECTRICAL POWER					
1 - 24V Main Battery	1	1	1	1	
2 - 28V Alternator	1	1	1	1	
3 - 24V Standby Battery	0	*	*	*	* Refer to Note 1.
4 - Main Ammeter	1	1	1	1	
5 - Standby Ammeter	0	*	*	*	* Refer to Note 1.

NOTE

1. The European Aviation Safety Agency (EASA) requires the 24V Standby Battery and Standby Ammeter to successfully complete the pre-flight check before operating the airplane in VFR night, IFR day, or IFR night conditions in Europe. Correct operation of the 24V Standby Battery and Standby Ammeter is recommended for all other operations.

(Continued Next Page)

KINDS OF OPERATIONS EQUIPMENT LIST (Continued)

System, Instrument, Equipment and/or Function	KIND OF OPERATION				COMMENTS
	V F R D A Y	V F R N I G H T	I F R D A Y	I F R N I G H T	
EQUIPMENT AND FURNISHINGS					
1 - Seat Belt Assembly	1	1	1	1	Each Seat Occupant
2 - Shoulder Harness	1	1	1	1	Front Seat Occupants
FLIGHT CONTROLS					
1 - Flap Position Indicator	1	1	1	1	
2 - Flap Motor	1	1	1	1	
3 - Elevator Trim System	1	1	1	1	
4 - Elevator Trim Indicator	1	1	1	1	
5 - Rudder Trim System	1	1	1	1	
6 - Rudder Trim Indicator	1	1	1	1	
FUEL SYSTEM					
1 - Electric Fuel Pump	1	1	1	1	
2 - Fuel Quantity Indicator - L Tank	1	1	1	1	
3 - Fuel Quantity Indicator - R Tank	1	1	1	1	
ICE AND RAIN PROTECTION					
1 - Alternate Static Air Source	0	0	1	1	
2 - Alternate Induction Air System	0	0	1	1	
INDICATING/RECORDING SYSTEM					
1 - Stall Warning System	1	1	1	1	
2 - System Annunciator and Warning Displays	1	1	1	1	
LANDING GEAR					
1 - Wheel Fairings	0	0	0	0	Removable

(Continued Next Page)

KINDS OF OPERATIONS EQUIPMENT LIST (Continued)

System, Instrument, Equipment and/or Function	KIND OF OPERATION				COMMENTS
	VFR DAY	VFR NIGHT	IFR DAY	IFR NIGHT	
LIGHTING					
1 - PFD Bezel Lighting	0	0	0	1	
2 - PFD Backlighting	*	1	1	1	*Refer to Note 2.
3 - MFD Bezel Lighting	0	0	0	1	
4 - MFD Backlighting	*	1	1	1	*Refer to Note 3.
5 - Switch and Circuit Breaker Panel Lighting	0	1	0	1	
6 - Standby Airspeed Indicator Internal Lighting	0	1	0	1	
7 - Standby Altimeter Internal Lighting	0	1	0	1	
8 - Non-stabilized Magnetic Compass Internal Lighting	0	1	0	1	
9 - Standby Attitude Indicator Internal Lighting	0	1	0	1	
10 - Cockpit Flood Light	0	1	0	1	
11 - Aircraft Position (NAV) Lights	0	1	1	1	
12 - STROBE Light System	1	1	1	1	
13 - BEACON Light	0	0	0	0	
14 - TAXI Light	0	0	0	0	
15 - LAND (Landing) Light	0	1	0	1	Operations for hire only

NOTE

2. PFD backlighting is required for day VFR flight if MFD backlighting has failed. Display backup mode must be active so engine indicators are shown.
3. MFD backlighting is required for day VFR flight if PFD backlighting has failed. Display backup mode must be active so flight instruments are shown.

(Continued Next Page)

KINDS OF OPERATIONS EQUIPMENT LIST (Continued)

System, Instrument, Equipment and/or Function	KIND OF OPERATION				COMMENTS
	V F R	V F R N I G H T	I F R D A Y	I F R N I G H T	
NAVIGATION AND PITOT-STATIC SYSTEM					
1 - G1000 Airspeed Indicator	1	1	1	1	
2 - Standby Airspeed Indicator	0	0	1	1	
3 - G1000 Altimeter	1	1	1	1	
4 - Standby Altimeter	0	0	1	1	
5 - G1000 Vertical Speed Indicator	0	0	0	0	
6 - G1000 Attitude Indicator	0	0	1	1	
7 - Standby Attitude Indicator	0	0	1	1	
8 - G1000 Directional Indicator (HSI)	0	0	1	1	
9 - G1000 Turn Coordinator	0	0	1	1	
10 - Non-stabilized Magnetic Compass	1	1	1	1	
11 - VHF Navigation Radio (VOR/LOC/GS)	0	0	A/R	A/R	As Required Per Procedure.
12 - GPS Receiver/Navigator	0	0	A/R	A/R	As Required Per Procedure.
13 - Marker Beacon Receiver	0	0	A/R	A/R	As Required Per Procedure.
14 - Blind Altitude Encoder	A/R	A/R	1	1	As Required Per Regulations.
15 - Clock	0	0	1	1	
16 - GFC 700 AFCS	0	0	0	0	

(Continued Next Page)

KINDS OF OPERATIONS EQUIPMENT LIST (Continued)

System, Instrument, Equipment and/or Function	KIND OF OPERATION				COMMENTS
	V F R D A Y	V F R N I G H T	I F R D A Y	I F R N I G H T	
VACUUM					
1 - Engine Driven Vacuum Pump	0	0	1	1	
2 - Vacuum Indicator	0	0	1	1	
ENGINE FUEL AND CONTROL					
1 - Manifold Pressure Indicator	1	1	1	1	
2 - Fuel Flow Indicator	1	1	1	1	
ENGINE INDICATING					
1 - Tachometer (RPM)	1	1	1	1	Cylinder #3
2 - Cylinder Head Temperature (CHT) Indicator	1	1	1	1	
3 - Oil Pressure Indicator	1	1	1	1	
4 - Oil Temperature Indicator	1	1	1	1	
ENGINE OIL					
1 - Engine Crankcase Dipstick	1	1	1	1	

FUEL LIMITATIONS

Total Fuel: 92.0 U.S. Gallons (46.0 gallons per tank)
Usable Fuel: 87.0 U.S. Gallons (43.5 gallons per tank)
Unusable Fuel: 5.0 U.S. Gallons (2.5 gallons per tank)

NOTE

To ensure maximum fuel capacity and minimize crossfeeding when refueling, always park the airplane in a wings level, normal ground attitude and place the fuel selector in the LEFT or RIGHT position. Refer to Figure 1-1 for normal ground attitude definition.

Takeoff and land with the fuel selector valve handle in the BOTH position.

Maximum slip or skid duration with one tank dry: 30 seconds

Operation on either LEFT or RIGHT tank limited to level flight only.

With 1/4 tank or less, prolonged uncoordinated flight is prohibited when operating on either left or right tank.

Fuel remaining in the tank after the fuel quantity indicator reads 0 (red line) cannot be safely used in flight.

Approved Fuel Grades (and Colors):

- 100LL Grade Aviation Fuel (Blue)
- 100 Grade Aviation Fuel (Green)

FLAP LIMITATIONS

Approved Takeoff Range: UP to 20°
Approved Landing Range: UP to FULL

SYSTEM LIMITATIONS

AUX AUDIO SYSTEM

Use of the AUX AUDIO IN entertainment input is prohibited during takeoff and landing.

Use of the AUX AUDIO IN entertainment audio input and portable electronic devices (PED), such as cellular telephones, games, cassette, CD or MP3 players, is prohibited under IFR unless the operator of the airplane has determined that the use of the Aux Audio System and the connected portable electronic device(s) will not cause interference with the navigation or communication system of the airplane.

12V POWER SYSTEM

The 12 Volt Power System (POWER OUTLET 12V - 10A) is not certified for supplying power to flight-critical communications or navigation devices.

Use of the 12 Volt Power System is prohibited during takeoff and landing.

Use of the 12 Volt Power System is prohibited under IFR unless the operator of the airplane has determined that the use of the 12 VDC power supply and connected portable electronic device(s) will not cause interference with the navigation or communication systems of the airplane.

G1000 LIMITATIONS

The current Garmin G1000 Cockpit Reference Guide (CRG) Part Number and System Software Version that must be available to the pilot during flight are displayed on the MFD AUX group, SYSTEM STATUS page.

GPS based IFR enroute, oceanic and terminal navigation is prohibited unless the pilot verifies the currency of the database or verifies each selected waypoint for accuracy by reference to current approved data.

RNAV/GPS instrument approaches must be accomplished in accordance with approved instrument approach procedures that are retrieved from the G1000 navigation database. The G1000 database must incorporate the current update cycle.

Use of the NAVIGATION MAP page for pilotage navigation is prohibited. The Navigation Map is intended only to enhance situational awareness. Navigation is to be conducted using only current charts, data and authorized navigation facilities.

Use of the TRAFFIC MAP to maneuver the airplane to avoid traffic is prohibited. The Traffic Information System (TIS) is intended for advisory use only. TIS is intended only to help the pilot to visually locate traffic. It is the responsibility of the pilot to see and maneuver to avoid traffic.

Use of the TERRAIN PROXIMITY information for primary terrain avoidance is prohibited. The Terrain Proximity map is intended only to enhance situational awareness. It is the pilot's responsibility to provide terrain clearance at all times.

Navigation using the G1000 is not authorized north of 70° North latitude or south of 70° South latitude due to unsuitability of the magnetic fields near the Earth's poles. In addition, operations are not authorized in the following two regions:

1. North of 65° North latitude between longitude 75° W and 120° W (Northern Canada).
2. South of 55° South latitude between longitude 120° E and 165° E (region south of Australia and New Zealand).

(Continued Next Page)

G1000 LIMITATIONS (Continued)

The COM 1/2 (split COM) function of the Audio Panel is not approved for use. During COM 1/2 operation, transmission by one crew member inhibits reception by the other crew member.

The fuel quantity, fuel used and fuel remaining functions of the G1000 are supplemental information only and must be verified by the pilot.

GPS - WAAS (Serials 18281869 and 18281876 thru 18282021 and 18282023 thru 18282045 not incorporating SB08-34-01)

Use of the Garmin G1000 system for GPS or WAAS navigation under Instrument Flight Rules (IFR) requires that:

1. The airplane must be equipped with an approved and operational alternate means of navigation appropriate to the route being flown (NAV receiver, DME or ADF).
2. For flight planning purposes, if an alternate airport is required, it must have an approved instrument approach procedure, other than GPS or RNAV, that is anticipated to be operational and available at the estimated time of arrival. All equipment required for this procedure must be installed and operational.
3. For procedures requiring a prediction of GPS Receiver Autonomous Integrity Monitoring (RAIM) capability for TSO-C129a (non-WAAS) equipment (e.g. oceanic operations, U.S. RNAV routes, European BRNAV and PRNAV, etc.), the Garmin WAAS Fault Detection/Exclusion Prediction program (006-A0154-01 or later approved version) should be used to confirm the availability of RAIM for the intended route and time of flight. Generic prediction tools do not provide an accurate indication of RAIM availability for the Garmin G1000 system.
4. When flight planning an LNAV/VNAV or LPV approach, the Garmin WAAS Fault Detection/Exclusion Prediction program (006-A0154-01 or later approved version) should be used in addition to any NOTAMS issued from the approach.

(Continued Next Page)

G1000 LIMITATIONS (Continued)

GARMIN GFC 700 AFCS

1. The GFC 700 AFCS preflight test must be successfully completed prior to use of the autopilot, flight director or manual electric trim.
2. A pilot, with the seat belt fastened, must occupy the left pilot's seat during all autopilot operations.
3. The autopilot must be off during all takeoff and landings.
4. Autopilot maximum engagement speed - 165 KIAS.
Autopilot minimum engagement speed - 70 KIAS.
Electric Trim maximum operating speed - 175 KIAS.
5. Maximum fuel imbalance with autopilot engaged - 90 pounds.
6. The autopilot must be disengaged below 200 feet AGL during approach operations and below 800 feet AGL during all other operations.
7. ILS approaches using the autopilot/flight director are limited to Category I approaches only.
8. Use of the autopilot is prohibited when the audio panel is inoperative (since the aural alert will not be provided when autopilot is disengaged).
9. Use of the autopilot is prohibited when conducting missed approach procedures until an established rate of climb that ensures all altitude requirements of the procedure will be met.

L3 COMMUNICATIONS WX 500 STORMSCOPE

Use of the WEATHER MAP (WX-500 Stormscope) for hazardous weather (thunderstorm) penetration is prohibited. LTNG information on the NAVIGATION MAP or WEATHER MAP is approved only as an aid to hazardous weather avoidance, not penetration.

(Continued Next Page)

G1000 LIMITATIONS (Continued)

TRAFFIC ADVISORY SYSTEM (TAS)

Use of the TRAFFIC MAP to maneuver the airplane to avoid traffic is prohibited. The Traffic Advisory System (TAS) is intended for advisory use only. TAS is intended only to help the pilot to visually locate traffic. It is the responsibility of the pilot to see and maneuver to avoid traffic.

TERRAIN AWARENESS AND WARNING SYSTEM (TAWS-B)

Use of the Terrain Awareness and Warning System (TAWS-B) to navigate to avoid terrain or obstacles is prohibited. TAWS-B is only approved as an aid to help the pilot to see-and-avoid terrain or obstacles.

TAWS-B must be inhibited when landing at a location not included in the airport database.

Use of TAWS-B is prohibited when operating using the QFE altimeter setting (altimeter indicates 0 feet altitude when the airplane is on the runway).

The pilot is authorized to deviate from the current ATC clearance only to the extent necessary to comply with TAWS-B warnings.

The geographic area of the TAWS-B database must match the geographic area in which the airplane is being operated.

PLACARDS

The following information must be displayed in the form of composite or individual placards.

1. In full view of the pilot: (The "DAY-NIGHT-VFR-IFR" entry, shown on the example below, will vary with installed equipment).

B6142

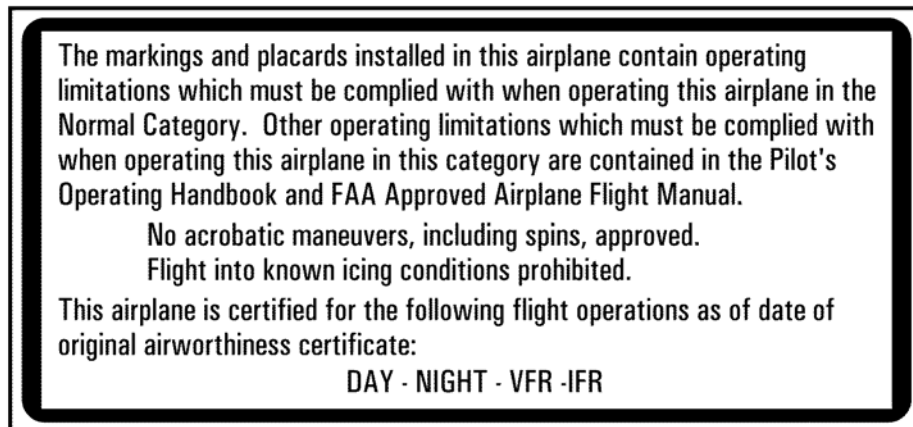

2. On control lock:

B6143

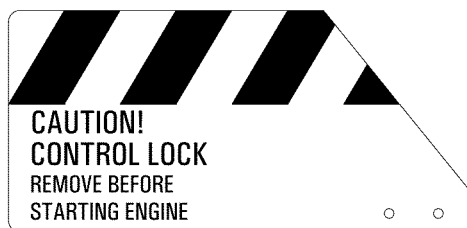

(Continued Next Page)

PLACARDS (Continued)

3. On the fuel selector valve:

B6144

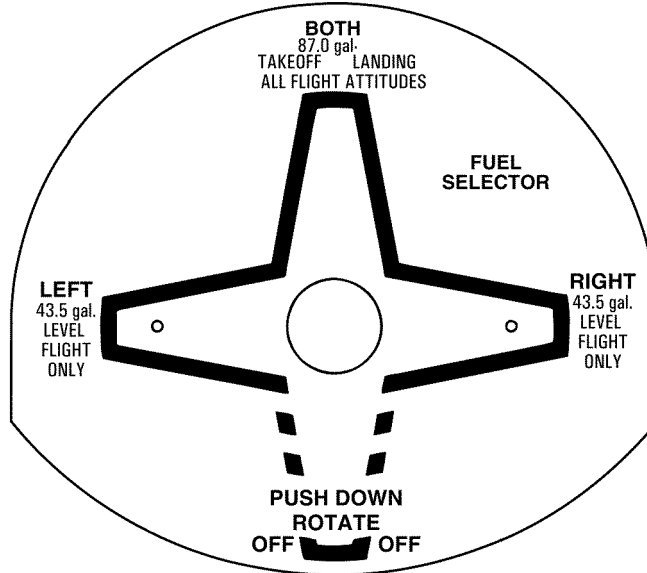

4. Near both fuel tank filler cap:

B6145

FUEL
100LL / 100 MIN. GRADE AVIATION GASOLINE
CAP. 43.5 U.S. GAL. (164 LITERS) USABLE
CAP. 37 U.S. GAL. (140 LITERS) USABLE TO LINE
OF HOLES INSIDE FILLER INDICATOR TAB.
CAP. 32 U.S. GAL. (121 LITERS) USABLE TO BOTTOM
OF FILLER INDICATOR TAB.

(Continued Next Page)

PLACARDS (Continued)

5. On flap control indicator:

B6146

UP to 10° 140 KIAS
(Initial flap range with Dark Blue color code; mechanical detent at 10° position)

10° to 20° 120 KIAS
(Intermediate flap range with Light Blue color code; mechanical detent at 20° position)

20° to FULL 100 KIAS
(Full flap range with White color code; mechanical stop at FULL position)

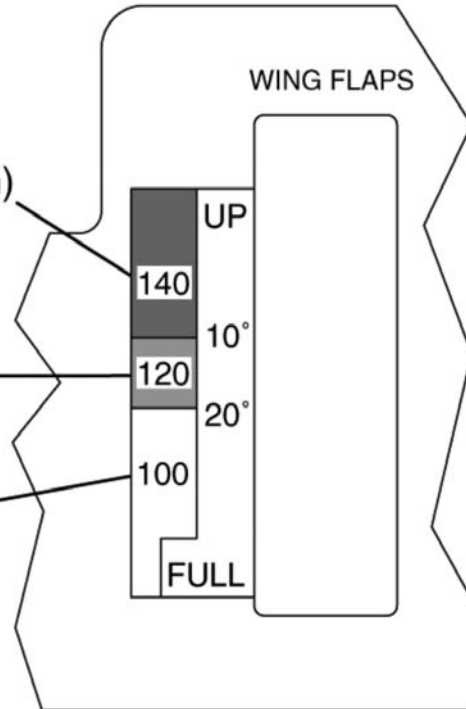

6. In baggage compartment:

B6147

**120 POUNDS MAXIMUM
BAGGAGE FWD OF BAGGAGE DOOR LATCH
AND 80 POUNDS MAXIMUM
BAGGAGE AFT OF BAGGAGE DOOR LATCH
MAXIMUM 200 POUNDS COMBINED**

**FOR ADDITIONAL LOADING INSTRUCTIONS
SEE WEIGHT AND BALANCE DATA**

(Continued Next Page)

PLACARDS (Continued)

7. A calibration card must be provided to indicate the accuracy of the magnetic compass in 30° increments.

B6148

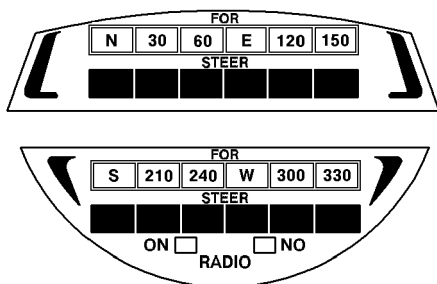

8. Molded on the oil filler cap/dipstick:

B6149

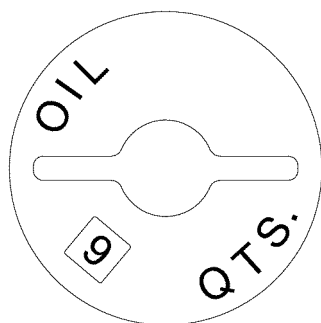

9. Silk-screened on the instrument panel directly above the PFD:

B6150

MANEUVERING SPEED: 110 KIAS

(Continued Next Page)

PLACARDS (Continued)

10. Silk-screened on the upper right instrument panel:

B6151

SMOKING PROHIBITED

11. On auxiliary power plug door and second placard on battery box:

B6152

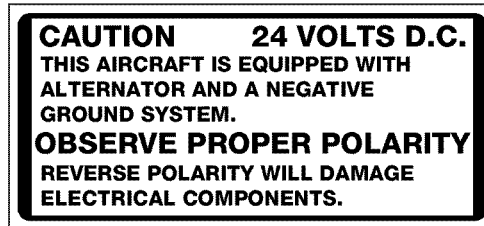

12. On the upper right side of the aft cabin partition:

B6153



OR

B7651



PLACARDS (Continued)

13. On the center overhead flood light control switch:

B6154

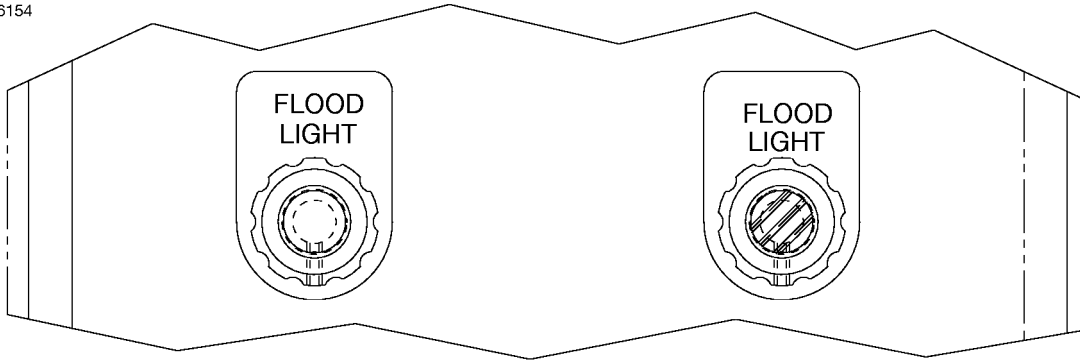

EMERGENCY PROCEDURES

TABLE OF CONTENTS

	Page
Introduction	3-5
Airspeeds For Emergency Operations.....	3-5
EMERGENCY PROCEDURES	3-6
ENGINE FAILURES	3-6
Engine Failure During Takeoff Roll	3-6
Engine Failure Immediately After Takeoff	3-6
Engine Failure During Flight (Restart Procedures)	3-7
FORCED LANDINGS	3-8
Emergency Landing Without Engine Power	3-8
Precautionary Landing With Engine Power.....	3-8
Ditching	3-9
FIRES	3-10
During Start On Ground	3-10
Engine Fire In Flight	3-11
Electrical Fire In Flight.....	3-11
Cabin Fire	3-12
Wing Fire.....	3-13
ICING	3-14
Inadvertent Icing Encounter During Flight.....	3-14
STATIC SOURCE BLOCKAGE	3-15
(Erroneous Instrument Reading Suspected).....	3-15
EXCESSIVE FUEL VAPOR	3-15
Fuel Flow Stabilization Procedures	3-15

(Continued Next Page)

TABLE OF CONTENTS (Continued)

	Page
ABNORMAL LANDINGS	3-16
Landing With A Flat Main Tire	3-16
Landing With A Flat Nose Tire	3-16
ELECTRICAL POWER SUPPLY SYSTEM MALFUNCTIONS ...	3-17
High Volts Annunciator Comes On or M BATT AMPS More Than 40	3-17
LOW VOLTS Annunciator Comes On Below 1000 RPM	3-19
LOW VOLTS Annunciator Comes On or Does Not Go Off at Higher RPM	3-19
AIR DATA SYSTEM FAILURE	3-21
Red X - PFD Airspeed Indicator	3-21
Red X - PFD Altitude Indicator	3-21
ATTITUDE AND HEADING REFERENCE SYSTEM (AHRS) FAILURE	3-21
Red X - PFD Attitude Indicator	3-21
Red X - Horizontal Situation Indicator (HSI)	3-21
AUTOPILOT OR ELECTRIC TRIM FAILURE	3-22
AP or PTRM Annunciator(s) Come On	3-22
DISPLAY COOLING ADVISORY	3-23
PFD1 COOLING or MFD1 COOLING Annunciator(s) Come On	3-23
VACUUM SYSTEM FAILURE	3-23
LOW VACUUM Annunciator Comes On	3-23
HIGH CARBON MONOXIDE (CO) LEVEL ADVISORY	3-24
CO LVL HIGH Annunciator Comes On	3-24
CO LVL HIGH Annunciator Remains On	3-24

(Continued Next Page)

TABLE OF CONTENTS (Continued)

	Page
AMPLIFIED EMERGENCY PROCEDURES	3-25
Engine Failure	3-25
Maximum Glide	3-26
Forced Landings	3-27
Landing Without Elevator Control	3-28
Fires	3-28
Emergency Operation In Clouds	3-29
Executing A 180° Turn In Clouds (AHRS FAILED)	3-29
Emergency Descent Through Clouds (AHRS FAILED)	3-30
Recovery From Spiral Dive In The Clouds (AHRS FAILED)	3-31
Inadvertent Flight Into Icing Conditions	3-31
Static Source Blocked	3-32
Spins	3-32
Rough Engine Operation Or Loss Of Power	3-33
Spark Plug Fouling	3-33
Magneto Malfunction	3-33
Engine-Driven Fuel Pump Failure	3-33
Excessive Fuel Vapor	3-34
Low Oil Pressure	3-34
Electrical Power Supply System Malfunctions	3-35
Excessive Rate Of Charge	3-35
Insufficient Rate Of Charge	3-36
High Carbon Monoxide (CO) Level Annunciation	3-38
Other Emergencies	3-38
Windshield Damage	3-38

INTRODUCTION

Section 3 provides checklist and amplified procedures for coping with emergencies that may occur. Emergencies caused by airplane or engine malfunctions are extremely rare if proper preflight inspections and maintenance are practiced. Enroute weather emergencies can be minimized or eliminated by careful flight planning and good judgment when unexpected weather is encountered. However, should an emergency arise, the basic guidelines described in this section should be considered and applied as necessary to correct the problem. In any emergency situation, the most important task is continued control of the airplane and maneuver to execute a successful landing.

Emergency procedures associated with optional or supplemental equipment are found in Section 9, Supplements.

AIRSPEEDS FOR EMERGENCY OPERATIONS

ENGINE FAILURE AFTER TAKEOFF

Wing Flaps UP	75 KIAS
Wing Flaps 10° - FULL	70 KIAS

MANEUVERING SPEED

3100 POUNDS	110 KIAS
2600 POUNDS	101 KIAS
2100 POUNDS	91 KIAS

MAXIMUM GLIDE

3100 POUNDS	76 KIAS
2600 POUNDS	70 KIAS
2100 POUNDS	58 KIAS

PRECAUTIONARY LANDING WITH ENGINE POWER.70 KIAS

LANDING WITHOUT ENGINE POWER

Wing Flaps UP	75 KIAS
Wing Flaps 10° - FULL	70 KIAS

EMERGENCY PROCEDURES

Procedures in the Emergency Procedures Checklist portion of this section shown in **bold faced** type are immediate action items which should be committed to memory.

ENGINE FAILURES

ENGINE FAILURE DURING TAKEOFF ROLL

1. **Throttle Control - IDLE (pull full out)**
2. **Brakes - APPLY**
3. Wing Flaps - RETRACT
4. Mixture Control - IDLE CUTOFF (pull full out)
5. MAGNETOS Switch - OFF
6. STBY BATT Switch - OFF
7. MASTER Switch (ALT and BAT) - OFF

ENGINE FAILURE IMMEDIATELY AFTER TAKEOFF

1. **Airspeed - 75 KIAS - Flaps UP**
70 KIAS - Flaps 10° - FULL
2. Mixture Control - IDLE CUTOFF (pull full out)
3. FUEL SELECTOR Valve - PUSH DOWN and ROTATE to OFF
4. MAGNETOS Switch - OFF
5. Wing Flaps - AS REQUIRED (FULL recommended)
6. STBY BATT Switch - OFF
7. MASTER Switch (ALT and BAT) - OFF
8. Cabin Door - UNLATCH
9. Land - STRAIGHT AHEAD

(Continued Next Page)

ENGINE FAILURES (Continued)

ENGINE FAILURE DURING FLIGHT (Restart Procedures)

1. **Airspeed - 76 KIAS (best glide speed)**
2. **FUEL SELECTOR Valve - BOTH**
3. **FUEL PUMP Switch - ON**
4. **Mixture Control - RICH (if restart has not occurred)**
5. **MAGNETOS Switch - BOTH (or START if propeller is stopped)**

NOTE

If the propeller is windmilling, engine will restart automatically within a few seconds. If propeller has stopped (possible at low speeds), turn MAGNETOS switch to START, advance throttle slowly from idle and lean the mixture from full rich as required to obtain smooth operation.

6. **FUEL PUMP Switch - OFF**

NOTE

If the indicated fuel flow (FFLOW GPH) immediately drops to zero, a sign of failure of the engine-driven fuel pump, return the FUEL PUMP switch to the ON position.

FORCED LANDINGS

EMERGENCY LANDING WITHOUT ENGINE POWER

1. Pilot and Passenger Seat Backs - MOST UPRIGHT POSITION
2. Seats and Seat Belts - SECURE
3. Airspeed - 75 KIAS - Flaps UP
70 KIAS - Flaps 10° - FULL
4. Mixture Control - IDLE CUTOFF (pull full out)
5. FUEL SELECTOR Valve - PUSH DOWN and ROTATE to OFF
6. MAGNETOS Switch - OFF
7. Wing Flaps - AS REQUIRED (FULL recommended)
8. STBY BATT Switch - OFF
9. MASTER Switch (ALT and BAT) - OFF (when landing is assured)
10. Doors - UNLATCH PRIOR TO TOUCHDOWN
11. Touchdown - SLIGHTLY TAIL LOW
12. Brakes - APPLY HEAVILY

PRECAUTIONARY LANDING WITH ENGINE POWER

1. Pilot and Passenger Seat Backs - MOST UPRIGHT POSITION
2. Seats and Seat Belts - SECURE
3. Airspeed - 75 KIAS
4. Wing Flaps - 20°
5. Selected Field - FLY OVER (noting terrain and obstructions)
6. Wing Flaps - FULL (on final approach)
7. Airspeed - 70 KIAS
8. STBY BATT Switch - OFF
9. MASTER Switch (ALT and BAT) - OFF (when landing assured)
10. Doors - UNLATCH PRIOR TO TOUCHDOWN
11. Touchdown - SLIGHTLY TAIL LOW
12. Mixture Control - IDLE CUTOFF (pull full out)
13. MAGNETOS Switch - OFF
14. Brakes - APPLY HEAVILY

(Continued Next Page)

FORCED LANDINGS (Continued)

DITCHING

1. Radio - TRANSMIT MAYDAY on 121.5 MHz, (give location, intentions and SQUAWK 7700)
2. Heavy Objects (in baggage area) - SECURE OR JETTISON (if possible)
3. Pilot and Passenger Seat Backs - MOST UPRIGHT POSITION
4. Seats and Seat Belts - SECURE
5. Wing Flaps - 20° to FULL
6. Power - ESTABLISH 300 FT/MIN DESCENT AT 65 KIAS

NOTE

If no power is available, approach at 70 KIAS with Flaps UP or at 65 KIAS with Flaps 10°.

7. Approach -High Winds, Heavy Seas - INTO THE WIND
Light Winds, Heavy Swells - PARALLEL TO SWELLS
8. Cabin Doors - UNLATCH
9. Touchdown - LEVEL ATTITUDE AT ESTABLISHED RATE OF DESCENT
10. Face - CUSHION AT TOUCHDOWN (with folded coat)
11. ELT - ACTIVATE
12. Airplane - EVACUATE THROUGH CABIN DOORS

NOTE

If necessary, open window and flood cabin to equalize pressure so doors can be opened.

13. Life Vests and Raft - INFLATE WHEN CLEAR OF AIRPLANE

FIRES

DURING START ON GROUND

1. **MAGNETOS Switch - START (continue cranking to start the engine)**

IF ENGINE STARTS

2. Power - 1800 RPM (for a few minutes)
3. Engine - SHUTDOWN (inspect for damage)

IF ENGINE FAILS TO START

2. **Throttle Control - FULL (push full in)**
3. **Mixture Control - IDLE CUTOFF (pull full out)**
4. **MAGNETOS Switch - START (continue cranking)**
5. **FUEL SELECTOR Valve - PUSH DOWN and ROTATE to OFF**
6. **FUEL PUMP Switch - OFF**
7. **MAGNETOS Switch - OFF**
8. **STBY BATT Switch - OFF**
9. **MASTER Switch (ALT and BAT) - OFF**
10. Engine - SECURE
11. Parking Brake - RELEASE
12. Fire Extinguisher - OBTAIN (have ground attendants obtain if not installed)
13. Airplane - EVACUATE
14. Fire - EXTINGUISH (using fire extinguisher, wool blanket, or dirt)
15. Fire Damage - INSPECT (repair or replace damaged components and/or wiring before conducting another flight)

(Continued Next Page)

FIRES (Continued)

ENGINE FIRE IN FLIGHT

1. **Mixture Control - IDLE CUTOFF (pull full out)**
2. **FUEL SELECTOR Valve - PUSH DOWN and ROTATE to OFF**
3. **FUEL PUMP Switch - OFF**
4. **MASTER Switch (ALT and BAT) - OFF**
5. Cabin Vents - OPEN (as needed)
6. CABIN HT and CABIN AIR Control Knobs - OFF (push full in)
7. Airspeed - 100 KIAS (If fire is not extinguished, increase glide speed to find an airspeed, within airspeed limitations, which will provide an incombustible mixture)
8. Forced Landing - EXECUTE (refer to EMERGENCY LANDING WITHOUT ENGINE POWER)

ELECTRICAL FIRE IN FLIGHT

1. **STBY BATT Switch - OFF**
2. **MASTER Switch (ALT and BAT) - OFF**
3. **Cabin Vents - CLOSED (to avoid drafts)**
4. **CABIN HT and CABIN AIR Control Knobs - OFF (push full in) (to avoid drafts)**
5. **Fire Extinguisher - ACTIVATE (if available)**
6. AVIONICS Switch (BUS 1 and BUS 2) - OFF
7. All Other Switches (except MAGNETOS switch) - OFF

WARNING

AFTER THE FIRE EXTINGUISHER HAS BEEN USED, MAKE SURE THAT THE FIRE IS EXTINGUISHED BEFORE EXTERIOR AIR IS USED TO REMOVE SMOKE FROM THE CABIN.

8. Cabin Vents - OPEN (when sure that fire is completely extinguished)
9. CABIN HT and CABIN AIR Control Knobs - ON (pull full out) (when sure that fire is completely extinguished)

(Continued Next Page)

FIRES (Continued)

ELECTRICAL FIRE IN FLIGHT (Continued)

IF FIRE HAS BEEN EXTINGUISHED AND ELECTRICAL POWER IS NECESSARY FOR CONTINUED FLIGHT TO NEAREST SUITABLE AIRPORT OR LANDING AREA

10. Circuit Breakers - CHECK (for OPEN circuit(s), do not reset)
11. MASTER Switch (ALT and BAT) - ON
12. STBY BATT Switch - ARM
13. AVIONICS Switch (BUS 1) - ON
14. AVIONICS Switch (BUS 2) - ON

CABIN FIRE

1. STBY BATT Switch - OFF
2. MASTER Switch (ALT and BAT) - OFF
3. Cabin Vents - CLOSED (to avoid drafts)
4. CABIN HT and CABIN AIR Control Knobs - OFF (push full in) (to avoid drafts)
5. Fire Extinguisher - ACTIVATE (if available)

WARNING

AFTER THE FIRE EXTINGUISHER HAS BEEN USED, MAKE SURE THAT THE FIRE IS EXTINGUISHED BEFORE EXTERIOR AIR IS USED TO REMOVE SMOKE FROM THE CABIN.

6. Cabin Vents - OPEN (when sure that fire is completely extinguished)
7. CABIN HT and CABIN AIR Control Knobs - ON (pull full out) (when sure that fire is completely extinguished)
8. Land the airplane as soon as possible to inspect for damage.

FIRES (Continued)

WING FIRE

1. **LAND and TAXI Light Switches - OFF**
2. **NAV Light Switch - OFF**
3. **STROBE Light Switch - OFF**
4. **PITOT HEAT Switch - OFF**

NOTE

Perform a sideslip to keep the flames away from the fuel tank and cabin. Land as soon as possible using flaps only as required for final approach and touchdown.

ICING

INADVERTENT ICING ENCOUNTER DURING FLIGHT

1. **PITOT HEAT Switch - ON**
2. **Turn back or change altitude (to obtain an outside air temperature that is less conducive to icing)**
3. **CABIN HT Control Knob - ON (pull full out)**
4. **DEFROST Control Knob - ON (rotate clockwise) (to obtain maximum defroster airflow)**
5. Increase engine speed to minimize ice build-up on propeller blades. If excessive vibration is noted, momentarily reduce engine speed to 2200 RPM with the propeller control, and then rapidly move the control forward.

NOTE

Cycling the RPM flexes the propeller blades and high RPM increases centrifugal force, causing ice to shed more rapidly.

6. Watch for signs of induction air filter icing. A loss of manifold pressure could be caused by ice blocking the air intake filter. Adjust the throttle as necessary to hold manifold pressure. Adjust mixture as necessary for any change in power settings.
7. Plan a landing at the nearest airport. With an extremely rapid ice build-up, select a suitable off airport landing site.
8. With an ice accumulation of 0.25 inch or more on the wing leading edges, be prepared for significantly higher power requirements, higher approach and stall speeds, and a longer landing roll.
9. Leave wing flaps retracted. With a severe ice build-up on the horizontal tail, the change in wing wake airflow direction caused by wing flap extension could result in a loss of elevator effectiveness.
10. Open left window and, if practical, scrape ice from a portion of the windshield for visibility in the landing approach.
11. Perform a landing approach using a forward slip, if necessary, for improved visibility.
12. Approach at 80 to 90 KIAS depending upon the amount of ice accumulation.
13. Perform landing in level attitude.
14. Missed approaches should be avoided whenever possible because of severely reduced climb capability.

STATIC SOURCE BLOCKAGE (ERRONEOUS INSTRUMENT READING SUSPECTED)

1. **ALT STATIC AIR Valve - ON (pull full out)**
2. Cabin Vents - CLOSED
3. CABIN HT and CABIN AIR Control Knobs - ON (pull full out)
4. Airspeed - Refer to Section 5, Figure 5-1 (Sheet 2) Airspeed Calibration, Alternate Static Source correction chart.
5. Altitude - Refer to Section 5, Figure 5-2, Altimeter Correction, Alternate Static Source correction chart.

EXCESSIVE FUEL VAPOR

FUEL FLOW STABILIZATION PROCEDURES

(If flow fluctuations of 1 GPH or more, or power surges occur.)

1. FUEL PUMP Switch - ON
2. Mixture Control - ADJUST (as necessary for smooth engine operation)
3. Fuel Selector Valve - SELECT OPPOSITE TANK (if vapor symptoms continue)
4. FUEL PUMP Switch - OFF (after fuel flow has stabilized)

ABNORMAL LANDINGS

LANDING WITH A FLAT MAIN TIRE

1. Approach - NORMAL
2. Wing Flaps - FULL
3. Touchdown - GOOD MAIN TIRE FIRST (hold airplane off flat tire as long as possible with aileron control)
4. Directional Control - MAINTAIN (using brake on good wheel as required)

LANDING WITH A FLAT NOSE TIRE

1. Approach - NORMAL
2. Wing Flaps - AS REQUIRED
 - 120 to 140 KIAS - Flaps UP to 10°
 - 100 to 120 KIAS - Flaps 10° to 20°
 - Below 100 KIAS - Flaps FULL
3. Touchdown - ON MAINS (hold nosewheel off the ground as long as possible)
4. When nosewheel touches down, maintain full up elevator as airplane slows to stop.

ELECTRICAL POWER SUPPLY SYSTEM MALFUNCTIONS

HIGH VOLTS ANNUNCIATOR COMES ON OR M BATT AMPS MORE THAN 40

1. MASTER Switch (ALT Only) - OFF
2. Electrical Load - REDUCE IMMEDIATELY as follows:
 - a. AVIONICS Switch (BUS 1) - OFF
 - b. PITOT HEAT Switch - OFF
 - c. BEACON Light Switch - OFF
 - d. LAND Light Switch - OFF (use as required for landing)
 - e. TAXI Light Switch - OFF
 - f. NAV Light Switch - OFF
 - g. STROBE Light Switch - OFF
 - h. CABIN PWR 12V Switch - OFF

NOTE

- The main battery supplies electrical power to the main and essential buses until M BUS VOLTS decreases below 20 volts. When M BUS VOLTS falls below 20 volts, the standby battery system will automatically supply electrical power to the essential bus for at least 30 minutes.
- Select COM1 MIC and NAV1 on the audio panel and tune to the active frequency before setting AVIONICS BUS 2 to OFF. If COM2 MIC and NAV2 are selected when AVIONICS BUS 2 is set to OFF, the COM and NAV radios cannot be tuned.

(Continued Next Page)

ELECTRICAL POWER SUPPLY SYSTEM
MALFUNCTIONS (Continued)

HIGH VOLTS ANNUNCIATOR COMES ON OR M BATT
AMPS MORE THAN 40 (Continued)

- i. COM1 and NAV1 - TUNE TO ACTIVE FREQUENCY
- j. COM1 MIC and NAV1 - SELECT (COM2 MIC and NAV2 will be inoperative once AVIONICS BUS 2 is selected to OFF)

NOTE

When AVIONICS BUS 2 is set to OFF, the following items will not operate:

Autopilot	Audio Panel
COMM 2	NAV 2
Transponder	MFD

- k. AVIONICS Switch (BUS 2) - OFF (KEEP ON if in clouds)
3. Land as soon as practical.

NOTE

Make sure a successful landing is possible before extending flaps. The flap motor is a large electrical load during operation.

(Continued Next Page)

ELECTRICAL POWER SUPPLY SYSTEM MALFUNCTIONS (Continued)

LOW VOLTS ANNUNCIATOR COMES ON BELOW 1000 RPM

1. Throttle Control - 1000 RPM
2. LOW VOLTS Annunciator - CHECK OFF

LOW VOLTS ANNUNCIATOR REMAINS ON AT 1000 RPM

3. Authorized maintenance personnel must do electrical system inspection prior to next flight.

LOW VOLTS ANNUNCIATOR COMES ON OR DOES NOT GO OFF AT HIGHER RPM

1. MASTER Switch (ALT Only) - OFF
2. ALT FIELD Circuit Breaker - CHECK IN
3. MASTER Switch (ALT and BAT) - ON
4. LOW VOLTS Annunciator - CHECK OFF
5. M BUS VOLTS - CHECK 27.5 V (minimum)
6. M BATT AMPS - CHECK CHARGING (+)

IF LOW VOLTS ANNUNCIATOR REMAINS ON

7. MASTER Switch (ALT Only) - OFF
8. Electrical Load - REDUCE IMMEDIATELY as follows:
 - a. AVIONICS Switch (BUS 1) - OFF
 - b. PITOT HEAT Switch - OFF
 - c. BEACON Light Switch - OFF
 - d. LAND Light Switch - OFF (use as required for landing)
 - e. TAXI Light Switch - OFF
 - f. NAV Light Switch - OFF
 - g. STROBE Light Switch - OFF
 - h. CABIN PWR 12V Switch - OFF

(Continued Next Page)

ELECTRICAL POWER SUPPLY SYSTEM MALFUNCTIONS

(Continued)

IF LOW VOLTS ANNUNCIATOR REMAINS ON (Continued)

NOTE

- The main battery supplies electrical power to the main and essential buses until M BUS VOLTS decreases below 20 volts. When M BUS VOLTS falls below 20 volts, the standby battery system will automatically supply electrical power to the essential bus for at least 30 minutes.
- Select COM1 MIC and NAV1 on the audio panel and tune to the active frequency before setting AVIONICS BUS 2 to OFF. If COM2 MIC and NAV2 are selected when AVIONICS BUS 2 is set to OFF, the COM and NAV radios cannot be tuned.
 - i. COM1 and NAV1 - TUNE TO ACTIVE FREQUENCY
 - j. COM1 MIC and NAV1 - SELECT (COM2 MIC and NAV2 will be inoperative once AVIONICS BUS 2 is selected to OFF)

NOTE

When AVIONICS BUS 2 is set to OFF, the following items will not operate:

Autopilot	Audio Panel
COMM 2	NAV 2
Transponder	MFD

- k. AVIONICS Switch (BUS 2) - OFF (KEEP ON if in clouds)
9. Land as soon as practical.

NOTE

Make sure a successful landing is possible before extending flaps. The flap motor is a large electrical load during operation.

AIR DATA SYSTEM FAILURE

RED X - PFD AIRSPEED INDICATOR

1. ADC/AHRS Circuit Breakers - CHECK IN (ESS BUS and AVN BUS 1). If open, reset (close) circuit breaker. If circuit breaker opens again, do not reset.
2. Standby Airspeed Indicator - USE FOR AIRSPEED INFORMATION

RED X - PFD ALTITUDE INDICATOR

1. ADC/AHRS Circuit Breakers - CHECK IN (ESS BUS and AVN BUS 1). If open, reset (close) circuit breaker. If circuit breaker opens again, do not reset.
2. Standby Altimeter - CHECK current barometric pressure SET. USE FOR ALTITUDE INFORMATION.

ATTITUDE AND HEADING REFERENCE SYSTEM (AHRS) FAILURE

RED X - PFD ATTITUDE INDICATOR

1. ADC/AHRS Circuit Breakers - CHECK IN (ESS BUS and AVN BUS 1). If open, reset (close) circuit breaker. If circuit breaker opens again, do not reset.
2. Standby Attitude Indicator - USE FOR ATTITUDE INFORMATION

RED X - HORIZONTAL SITUATION INDICATOR (HSI)

1. ADC/AHRS Circuit Breakers - CHECK IN (ESS BUS and AVN BUS 1). If open, reset (close) circuit breaker. If circuit breaker opens again, do not reset.
2. Non-Stabilized Magnetic Compass - USE FOR HEADING INFORMATION

AUTOPILOT OR ELECTRIC TRIM FAILURE

AP OR PTRM ANNUNCIATOR(S) COME ON

1. **Control Wheel - GRASP FIRMLY (regain control of airplane)**
2. **A/P TRIM DISC Button - PRESS and HOLD (throughout recovery)**
3. **Elevator and Rudder Trim Controls - ADJUST MANUALLY (as necessary)**
4. **AUTO PILOT Circuit Breaker - OPEN (pull out)**
5. **A/P TRIM DISC Button - RELEASE**

WARNING

FOLLOWING AN AUTOPILOT, AUTOTRIM OR MANUAL ELECTRIC TRIM SYSTEM MALFUNCTION, DO NOT ENGAGE THE AUTOPILOT UNTIL THE CAUSE OF THE MALFUNCTION HAS BEEN CORRECTED.

DISPLAY COOLING ADVISORY

PFD1 COOLING OR MFD1 COOLING ANNUNCIATOR(S) COME ON

1. CABIN HT Control Knob - REDUCE (push in) (minimum preferred)
2. Forward Avionics Fan - CHECK (feel for airflow from screen on glareshield)

IF FORWARD AVIONICS FAN HAS FAILED

3. STBY BATT Switch - OFF (unless needed for emergency power)

IF PFD1 COOLING OR MFD1 COOLING ANNUNCIATOR DOES NOT GO OFF WITHIN 3 MINUTES OR IF BOTH PFD1 COOLING AND MFD1 COOLING ANNUNCIATORS COME ON

3. STBY BATT Switch - OFF (land as soon as practical)

VACUUM SYSTEM FAILURE

LOW VACUUM ANNUNCIATOR COMES ON

1. Vacuum Indicator (VAC) - CHECK EIS SYSTEM PAGE (make sure vacuum pointer is in green band limits)

CAUTION

IF VACUUM POINTER IS OUT OF THE GREEN BAND DURING FLIGHT OR THE GYRO FLAG IS SHOWN ON THE STANDBY ATTITUDE INDICATOR, THE STANDBY ATTITUDE INDICATOR MUST NOT BE USED FOR ATTITUDE INFORMATION.

HIGH CARBON MONOXIDE (CO) LEVEL ADVISORY

CO LVL HIGH ANNUNCIATOR COMES ON

1. **CABIN HT Control Knob - OFF (push full in)**
2. **CABIN AIR Control Knob - ON (pull full out)**
3. **Cabin Vents - OPEN**
4. Cabin Windows - OPEN (175 KIAS maximum windows open speed)

CO LVL HIGH ANNUNCIATOR REMAINS ON

5. Land as soon as practical.

AMPLIFIED EMERGENCY PROCEDURES

The following Amplified Emergency Procedures provide additional information beyond that in the Emergency Procedures Checklists portion of this section. These procedures also include information not readily adaptable to a checklist format, and material to which a pilot could not be expected to refer in resolution of a specific emergency. This information should be reviewed in detail prior to flying the airplane, as well as reviewed on a regular basis to keep pilot's knowledge of procedures fresh.

ENGINE FAILURE

If an engine failure occurs during the takeoff roll, stop the airplane on the remaining runway. Those extra items on the checklist will provide added safety after a failure of this type.

If an engine failure occurs immediately after takeoff, in most cases, the landing should be planned straight ahead with only small changes in direction to avoid obstructions. Altitude and airspeed are seldom sufficient to execute the 180° gliding turn necessary to return to the runway. The checklist procedures assume that adequate time exists to secure the fuel and ignition systems prior to touchdown.

After an engine failure in flight, the most important task is to continue flying the airplane. The best glide speed, as shown in Figure 3-1, should be established as quickly as possible. While gliding toward a suitable landing area, an effort should be made to identify the cause of the failure. If time permits, an engine restart should be attempted as shown in the checklist. If the engine cannot be restarted, a forced landing without power must be completed.

MAXIMUM GLIDE

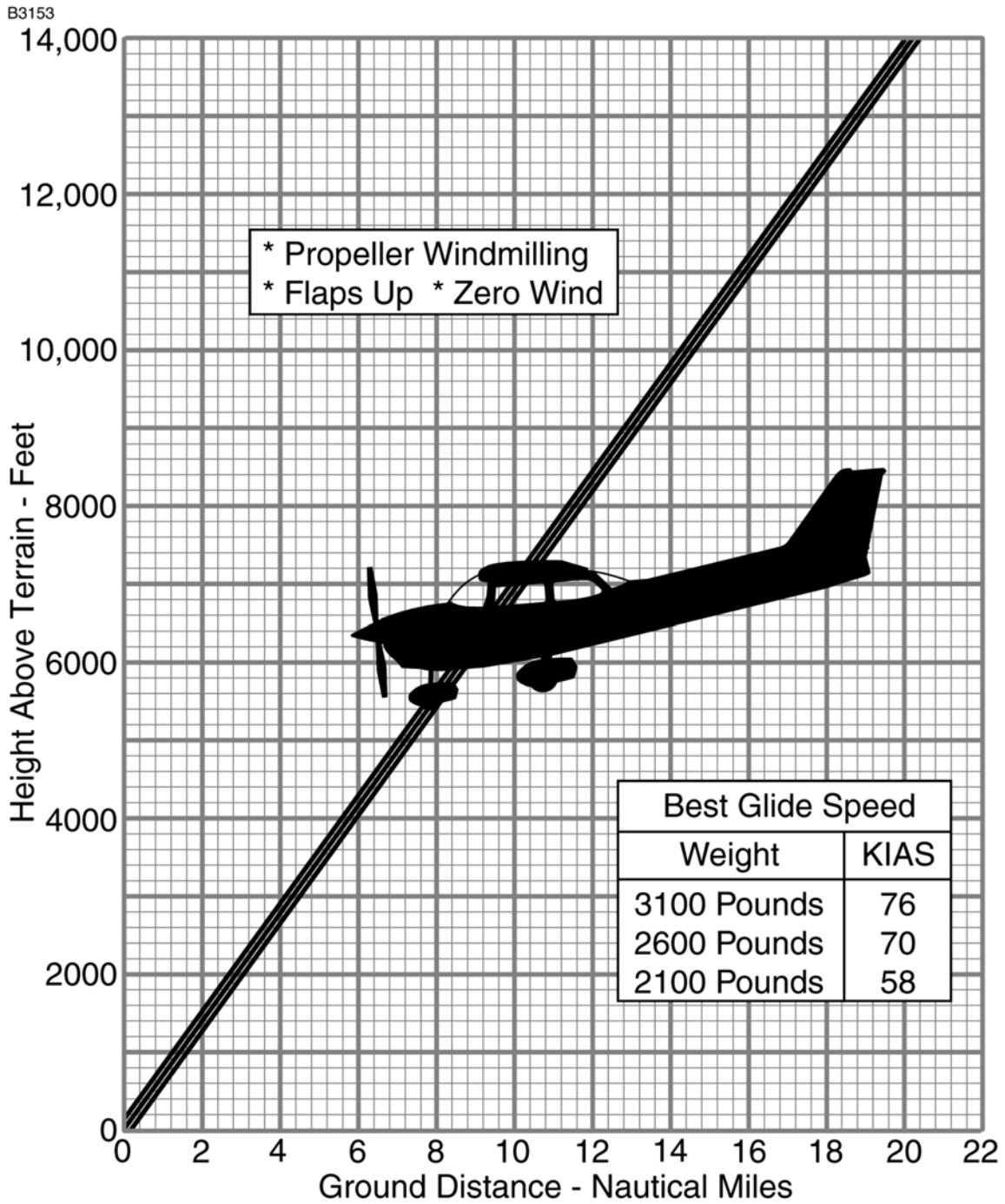

Figure 3-1

FORCED LANDINGS

If all attempts to restart the engine fail and a forced landing is imminent, select a suitable field and prepare for the landing as discussed under the Emergency Landing Without Engine Power checklist. Transmit Mayday message on 121.5 MHz giving location, intentions and squawk 7700.

Before attempting an off airport landing with engine power available, one should fly over the landing area at a safe, but low altitude, to inspect the terrain for obstructions and surface conditions, proceeding as discussed in the Precautionary Landing With Engine Power checklist.

Prepare for ditching by securing or jettisoning heavy objects located in the baggage area and collect folded coats for protection of occupants' face at touchdown. Transmit Mayday messages on 121.5 MHz giving location, intentions and squawk 7700. Avoid a landing flare because of the difficulty in judging height over a water surface. The checklist assumes the availability of power to make a precautionary water landing. If power is not available, use of the airspeeds noted with minimum flap extension will provide a more favorable attitude for a power off ditching.

In a forced landing situation, do not turn off the MASTER switch, AVIONICS switch or STBY BATT switch until a landing is assured. Premature deactivation of the switches will disable all airplane electrical systems.

Before completing a forced landing, especially in remote and mountainous areas, activate the ELT by setting the cockpit-mounted switch to the ON position. For complete information on ELT operation, refer to Section 9, Supplements.

LANDING WITHOUT ELEVATOR CONTROL

Trim for horizontal flight with an airspeed of approximately 80 KIAS by using throttle and elevator trim controls. Then **do not change the elevator trim control setting**; control the glide angle by adjusting power.

During the landing flare (round-out), the nose will come down when power is reduced and the airplane may touch down on the nosewheel before the main wheels. When in the flare, the elevator trim control should be adjusted toward the full nose up position and the power adjusted at the same time so that the airplane will rotate to a horizontal attitude for touchdown. Close the throttle at touchdown.

FIRES

Improper starting procedures involving the excessive use of auxiliary fuel pump operation can cause engine flooding and subsequent collection of fuel on the parking ramp as the excess fuel drains overboard from the intake manifolds. This is sometimes experienced in difficult starts in cold weather where engine preheat service is not available. If this occurs, the airplane should be pushed away from the fuel puddle before another engine start is attempted. Otherwise, there is a possibility of raw fuel accumulations in the exhaust system igniting during an engine start, causing a long flame from the tailpipe, and possibly igniting the collected fuel on the pavement. If a fire occurs, proceed according to the checklist.

Although engine fires are extremely rare in flight, if a fire is encountered, the steps of the appropriate checklist should be followed. After completion of the checklist procedure, execute a forced landing. Do not attempt to restart the engine.

The first sign of an electrical fire is usually the smell of burning insulation. The checklist procedure should result in the elimination of the fire.

EMERGENCY OPERATION IN CLOUDS

If the engine-driven vacuum pump fails in flight, the standby attitude indicator will not be accurate. The pilot must then rely on the attitude and heading information (from the AHRS) shown on the PFD indicators. With valid HDG or GPS/NAV inputs, autopilot operation will not be affected.

If the AHRS unit fails in flight (red X's shown through the PFD attitude and heading indicators), the pilot must rely on the standby attitude indicator and non-stabilized magnetic compass for attitude and heading information.

The autopilot will not operate if the AHRS unit fails. The pilot must manually fly the airplane without AHRS input. Refer to Section 7, Airplane and Systems Description, for additional details on autopilot operations.

The following instructions assume that the pilot is not very proficient at instrument flying and is flying the airplane without the autopilot engaged.

EXECUTING A 180° TURN IN CLOUDS (AHRS FAILED)

Upon inadvertently entering the clouds, an immediate turn to reverse course and return to VFR conditions should be made as follows:

AHRS FAILURE

1. Note the non-stabilized magnetic compass heading.
2. Set rudder trim to the neutral position.
3. Using the standby attitude indicator, initiate a 15° bank left turn. Keep feet off rudder pedals. Maintain altitude and 15° bank angle. Continue the turn for 60 seconds, then roll back to level flight.
4. When the compass card becomes sufficiently stable, check the accuracy of the turn by verifying that the compass heading approximates the reciprocal of the original heading.
5. If necessary, adjust the heading by keeping the wings level and using the rudder to make skidding turns (the compass will read more accurately) to complete the course reversal.
6. Maintain altitude and airspeed by cautious application of elevator control. Keep the roll pointer and index aligned and steer only with rudder.

(Continued Next Page)

EMERGENCY OPERATION IN CLOUDS (Continued)

EMERGENCY DESCENT THROUGH CLOUDS (AHRS FAILED)

When returning to VFR flight after a 180° turn is not practical, a descent through the clouds to VFR conditions below may be appropriate. If possible, obtain an ATC clearance for an emergency descent through the clouds.

AHRS FAILURE

Choose an easterly or westerly heading to minimize non-stabilized magnetic compass card sensitivity. Occasionally check the compass heading and make minor corrections to hold an approximate course. The autopilot will not operate if the AHRS unit fails. The pilot must manually fly the airplane without AHRS input.

Before descending into the clouds, prepare for a stabilized descent as follows:

1. Apply full rich mixture.
2. Set rudder trim to neutral position.
3. Turn pitot heat on.
4. Set power for a 500 to 800 feet per minute rate of descent.
5. Set the elevator trim for a stabilized descent at 80 KIAS.
6. Use the standby attitude indicator roll pointer and index to keep wings level.
7. Check trend of compass card movement and make cautious corrections with rudder to stop the turn.
8. Upon breaking out of clouds, resume normal cruising flight.

(Continued Next Page)

EMERGENCY OPERATION IN CLOUDS (Continued)

RECOVERY FROM SPIRAL DIVE IN THE CLOUDS (AHRS FAILED)

AHRS FAILURE

If a spiral is entered while in the clouds, continue as follows:

1. Retard throttle to idle position.
2. Remove feet from rudder pedals.
3. Stop turn by carefully leveling the wings using aileron control to align the roll index and roll pointer of the standby attitude indicator.
4. Cautiously apply elevator back pressure to slowly reduce the airspeed to 80 KIAS.
5. Adjust the elevator trim control to maintain an 80 KIAS glide.
6. Set rudder trim to neutral position.
7. Use aileron control to maintain wings level (keep roll pointer and index aligned) and constant heading.
8. Resume EMERGENCY DESCENT THROUGH THE CLOUDS procedure.
9. Upon breaking out of clouds, resume normal cruising flight.

INADVERTENT FLIGHT INTO ICING CONDITIONS

Flight into icing conditions is prohibited and extremely dangerous. An inadvertent encounter with these conditions can be resolved using the checklist procedures. The best action is to turn back or change altitude to escape icing conditions. Set the PITOT HEAT switch to the ON position until safely out of icing conditions.

During these encounters, an unexplained loss of manifold pressure could be caused by ice blocking the air intake filter or in extremely rare instances ice completely blocking the fuel injection air reference tubes. In either case, the throttle should be positioned to hold manifold pressure (in some instances, the throttle may need to be retarded for maximum power). Adjust mixture as necessary for any change in power settings.

STATIC SOURCE BLOCKED

If erroneous readings of the static source instruments (airspeed, altimeter and vertical speed) are suspected, the alternate static source air valve (ALT STATIC AIR) should be pulled ON, thereby supplying static pressure to these instruments from the cabin.

When the ALT STATIC AIR valve is ON, the maximum airspeed variation from normal static source operation is 5 knots and the maximum altimeter variation is 80 feet with all windows closed. Refer to Section 5, Figure 5-1 (Sheet 2), Airspeed Calibration, and Figure 5-2, Altimeter Correction tables, for Alternate Static Source for additional details.

SPINS

Intentional spins are prohibited in this airplane, but should an inadvertent spin occur, the following recovery procedure should be used:

1. RETARD THROTTLE TO IDLE POSITION.
2. PLACE AILERONS IN NEUTRAL POSITION.
3. APPLY AND **HOLD** FULL RUDDER OPPOSITE TO THE DIRECTION OF ROTATION.
4. JUST **AFTER** THE RUDDER REACHES THE STOP, MOVE THE CONTROL WHEEL **BRISKLY** FORWARD FAR ENOUGH TO BREAK THE STALL. Full down elevator may be required at aft center of gravity loadings to assure optimum recoveries.
5. **HOLD** THESE CONTROL INPUTS UNTIL ROTATION STOPS. Premature relaxation of the control inputs may extend the recovery.
6. AS ROTATION STOPS, NEUTRALIZE RUDDER, AND MAKE A SMOOTH RECOVERY FROM THE RESULTING DIVE.

NOTE

If the rate of the spin makes determining the direction of rotation difficult, the magenta turn rate indicator at the top of the HSI compass card will show the rate and direction of the turn. The HSI compass card will rotate in the opposite direction. Hold opposite rudder to the turn vector direction.

ROUGH ENGINE OPERATION OR LOSS OF POWER

SPARK PLUG FOULING

A slight engine roughness in flight may be caused by one or more spark plugs becoming fouled by carbon or lead deposits. This may be verified by turning the MAGNETOS switch momentarily from BOTH to either L or R position. An obvious power loss in single magneto operation is evidence of spark plug or magneto trouble. Since spark plugs are the more likely cause, lean the mixture to the recommended lean setting for cruising flight. If the problem does not clear up in several minutes, determine if a richer mixture setting will produce smoother operation. If not, proceed to the nearest airport for repairs using the BOTH position of the MAGNETOS switch unless extreme roughness makes the use of a single MAGNETO position necessary.

MAGNETO MALFUNCTION

Sudden engine roughness or misfiring is usually a sign of a magneto problem. Changing the MAGNETOS switch from BOTH to the L and R switch positions will identify which magneto is malfunctioning. Select different power settings and enrichen the mixture to determine if continued operation on BOTH magnetos is possible. If not, change to the good magneto and continue to the nearest airport for repairs.

ENGINE-DRIVEN FUEL PUMP FAILURE

Failure of the engine-driven fuel pump will be shown by a sudden reduction in the fuel flow indication (FFLOW GPH) **immediately before a loss of power** while operating from a fuel tank containing adequate fuel.

If the engine-driven fuel pump fails, immediately set the FUEL PUMP switch to the ON position to restore the engine power. The flight should be terminated as soon as practical and the engine-driven fuel pump repaired.

(Continued Next Page)

ROUGH ENGINE OPERATION OR LOSS OF POWER

(Continued)

EXCESSIVE FUEL VAPOR

Fuel vapor in the fuel injection system is most likely to occur on the ground, typically during prolonged taxi operations, when operating at higher altitudes and/or in unusually warm temperatures.

Excessive fuel vapor accumulation is shown by fuel flow indicator (FFLOW GPH) fluctuations greater than 1 gal./hr. This condition, with leaner mixtures or with larger fluctuations, can result in power surges, and if not corrected, may cause power loss.

To slow vapor formation and stabilize fuel flow on the ground or in the air, set the FUEL PUMP switch to the ON position and adjust the mixture as required for smooth engine operation. If vapor symptoms continue, select the opposite fuel tank. When fuel flow stabilizes, set the FUEL PUMP switch to the OFF position and adjust the mixture as desired.

LOW OIL PRESSURE

If the low oil pressure annunciator (OIL PRESS) comes on, check the oil pressure indicator (OIL PRES on ENGINE page or OIL PSI on SYSTEM page) to confirm low oil pressure condition. If oil pressure and oil temperature (OIL TEMP on ENGINE page or OIL °F on SYSTEM page) remain normal, it is possible that the oil pressure sending unit or relief valve is malfunctioning. Land at the nearest airport to determine the source of the problem.

If a total loss of oil pressure and a rise in oil temperature occur at about the same time, it could mean that the engine is about to fail. Reduce power immediately and select a field suitable for a forced landing. Use only the minimum power necessary to reach the landing site.

ELECTRICAL POWER SUPPLY SYSTEM MALFUNCTIONS

Malfunctions in the electrical power supply system can be detected through regular monitoring of the main battery ammeter (M BATT AMPS) and the main electrical bus voltmeter (M BUS VOLTS); however, the cause of these malfunctions is usually difficult to determine. A broken alternator drive belt, too much wear on the alternator brushes, or an error in wiring is most likely the cause of alternator failures, although other factors could cause the problem. A defective Alternator Control Unit (ACU) can also cause malfunctions. Problems of this nature constitute an electrical emergency and should be dealt with immediately. Electrical power malfunctions usually fall into two categories: excessive rate of charge and insufficient rate of charge. The following paragraphs describe the recommended remedy for each situation.

EXCESSIVE RATE OF CHARGE

After engine starting and heavy electrical usage at low engine speeds (such as extended taxiing), the battery condition will be low enough to accept above normal charging during the initial part of a flight. However, after thirty minutes of cruising flight, the main battery ammeter (M BATT AMPS) should be indicating less than 5 amps of charging (+) current. If the charging current remains above this value on a long flight, the battery electrolyte could overheat and evaporate.

Electronic components in the electrical system can be adversely affected by higher than normal voltage. The ACU includes an overvoltage sensor circuit which will automatically disconnect the alternator if the charge voltage increases to more than approximately 31.75 volts. If the overvoltage sensor circuit does not operate correctly, as shown by voltage more than 31.75 volts on the main battery bus voltmeter, the MASTER switch ALT section should be set to the OFF position. Unnecessary electrical equipment should be de-energized and the flight terminated as soon as practical.

(Continued Next Page)

ELECTRICAL POWER SUPPLY SYSTEM MALFUNCTIONS (Continued)

INSUFFICIENT RATE OF CHARGE

When the overvoltage sensor circuit, or other fault, opens the alternator (ALT FIELD) circuit breaker and de-energizes the alternator, a discharge (-) current will be shown on the main battery ammeter and the low voltage annunciator (LOW VOLTS) will come on. The ACU can de-energize the alternator due to minor disturbances in the electrical system, resulting in a nuisance opening of the ALT FIELD circuit breaker. If this happens, an attempt should be made to energize the alternator system.

To energize the alternator system

1. MASTER Switch (ALT Only) - OFF
2. ALT FIELD Circuit Breaker - CHECK IN
3. MASTER Switch (ALT Only) - ON

If the problem was a minor ACU disturbance in the electrical system, normal main battery charging will start. A charge (+) current will be shown on the main battery ammeter and the LOW VOLTS annunciator will go off.

If the LOW VOLTS annunciator comes on again, there is an alternator system problem. Do not repeat steps to energize the alternator system. The electrical load on the battery must be minimized (by de-energizing nonessential electrical equipment and avionics) because the battery can supply the electrical system for only a short time. Reduce electrical load as soon as possible to extend the life of the battery for landing. Land as soon as practical.

(Continued Next Page)

ELECTRICAL POWER SUPPLY SYSTEM MALFUNCTIONS (Continued)

INSUFFICIENT RATE OF CHARGE (Continued)

Main battery life can be extended by setting the MASTER switch (ALT and BAT) to OFF and operating the equipment on the ESS BUS from the standby battery. The standby battery is only capable of providing power for systems on the essential bus and cannot provide power for transponder (XPDR) operation. Main battery life should be extended, when practical, for possible later operation of the wing flaps and use of the landing light (at night).

NOTE

The LOW VOLTS annunciator can come on when the engine is operated at low RPM with a high electrical load. The LOW VOLTS annunciator will usually go off when the engine is operated at higher RPM for greater alternator system output. Make sure that the M BATT AMPS indication shows positive (+) current at the higher RPM.

HIGH CARBON MONOXIDE (CO) LEVEL ANNUNCIATION

Carbon monoxide (CO) is a colorless, odorless, tasteless product of an internal combustion engine and is always present in exhaust fumes. Even minute quantities of carbon monoxide breathed over a long period of time may lead to dire consequences. The symptoms of carbon monoxide poisoning are difficult to detect by the person affected and may include blurred thinking, a feeling of uneasiness, dizziness, headache, and loss of consciousness.

The cabin heater system operates by allowing ambient air to flow through an exhaust shroud where it is heated before being ducted into the cabin. If an exhaust leak, caused by a crack in the exhaust pipe, occurs in the area surrounded by this shroud it would allow exhaust fumes to mix with the heated ambient air being ducted into the cabin. Therefore, if anyone in the cabin smells exhaust fumes, experiences any of the symptoms mentioned above, or the CO LVL HIGH warning annunciation comes on when using the cabin heater, immediately turn off the cabin heater and perform the emergency items for HIGH CARBON MONOXIDE (CO) LEVEL.

When the CO detection system senses a CO level of 50 parts per million (PPM) by volume or greater, the alarm turns on a flashing warning annunciation CO LVL HIGH in the annunciation window on the PFD with a continuous tone until the PFD softkey below WARNING is pushed. It then remains on steady until the CO level drops below 50 PPM and automatically resets the alarm.

OTHER EMERGENCIES

WINDSHIELD DAMAGE

If a bird strike or other incident should damage the windshield in flight to the point of creating an opening, a significant loss in performance may be expected. This loss may be minimized in some cases (depending on amount of damage, altitude, etc.) by opening the side windows while the airplane is maneuvered for a landing at the nearest airport. If airplane performance or other adverse conditions prevent landing at an airport, prepare for an off airport landing in accordance with the Precautionary Landing With Engine Power or Ditching checklists.

NORMAL PROCEDURES

TABLE OF CONTENTS

	Page
Introduction	4-3
Airspeeds For Normal Operation	4-3
NORMAL PROCEDURES	4-4
Preflight Inspection	4-4
Cabin	4-5
Empennage	4-6
Right Wing Trailing Edge	4-6
Right Wing	4-7
Nose	4-8
Left Wing Leading Edge	4-9
Left Wing	4-10
Left Wing Trailing Edge	4-10
Before Starting Engine	4-11
Starting Engine (With Battery)	4-12
Starting Engine (With External Power)	4-13
Before Takeoff	4-15
Takeoff	4-18
Normal Takeoff	4-18
Short Field Takeoff	4-18
Enroute Climb	4-19
Normal Climb	4-19
Maximum Performance Climb	4-19
Cruise	4-19
Descent	4-20
Before Landing	4-21
Landing	4-21
Normal Landing	4-21
Short Field Landing	4-21
Balked Landing	4-22
After Landing	4-22
Securing Airplane	4-22

(Continued Next Page)

TABLE OF CONTENTS (Continued)

	Page
AMPLIFIED NORMAL PROCEDURES	4-23
Preflight Inspection	4-23
Starting Engine	4-25
Recommended Starter Duty Cycle	4-26
Leaning For Ground Operations	4-26
Taxiing	4-27
Before Takeoff	4-29
Warm Up	4-29
Magneto Check	4-29
Alternator Check	4-29
Elevator Trim	4-30
Landing Lights	4-30
Takeoff	4-30
Power Check	4-30
Wing Flap Settings	4-31
Crosswind Takeoff	4-31
Enroute Climb	4-32
Cruise	4-33
Leaning Using Exhaust Gas Temperature (EGT)	4-35
Fuel Savings Procedures For Normal Operations	4-38
Fuel Vapor Procedures	4-39
Stalls	4-40
Landing	4-41
Normal Landing	4-41
Short Field Landing	4-41
Crosswind Landing	4-42
Balked Landing	4-42
Cold Weather Operations	4-43
Starting	4-44
Winterization Kit	4-45
Hot Weather Operations	4-46
Noise Characteristics	4-46

INTRODUCTION

Section 4 provides procedures and amplified instructions for normal operations using standard equipment. Normal procedures associated with optional systems can be found in Section 9, Supplements.

AIRSPEEDS FOR NORMAL OPERATION

Unless otherwise noted, the following speeds are based on a maximum weight of 3100 pounds and may be used for any lesser weight.

TAKEOFF

Normal Climb	70 - 80 KIAS
Short Field Takeoff, Flaps 20°, Speed at 50 Feet	58 KIAS

ENROUTE CLIMB, FLAPS UP

Normal, Sea Level.	85 - 95 KIAS
Best Rate of Climb, Sea Level	80 KIAS
Best Rate of Climb, 10,000 Feet.	74 KIAS
Best Angle of Climb, Sea Level.	65 KIAS
Best Angle of Climb, 10,000 Feet	68 KIAS

LANDING APPROACH

Normal Approach, Flaps UP	70 - 80 KIAS
Normal Approach, Flaps FULL	60 - 70 KIAS
Short Field Approach, Flaps FULL	60 KIAS

BALKED LANDING

Maximum Power, Flaps 20°	55 KIAS
------------------------------------	---------

MAXIMUM RECOMMENDED TURBULENT AIR PENETRATION SPEED

3100 POUNDS	110 KIAS
2600 POUNDS	101 KIAS
2100 POUNDS	91 KIAS

MAXIMUM DEMONSTRATED CROSSWIND VELOCITY

Takeoff or Landing.	15 KNOTS
-----------------------------	----------

NORMAL PROCEDURES

PREFLIGHT INSPECTION

B3154

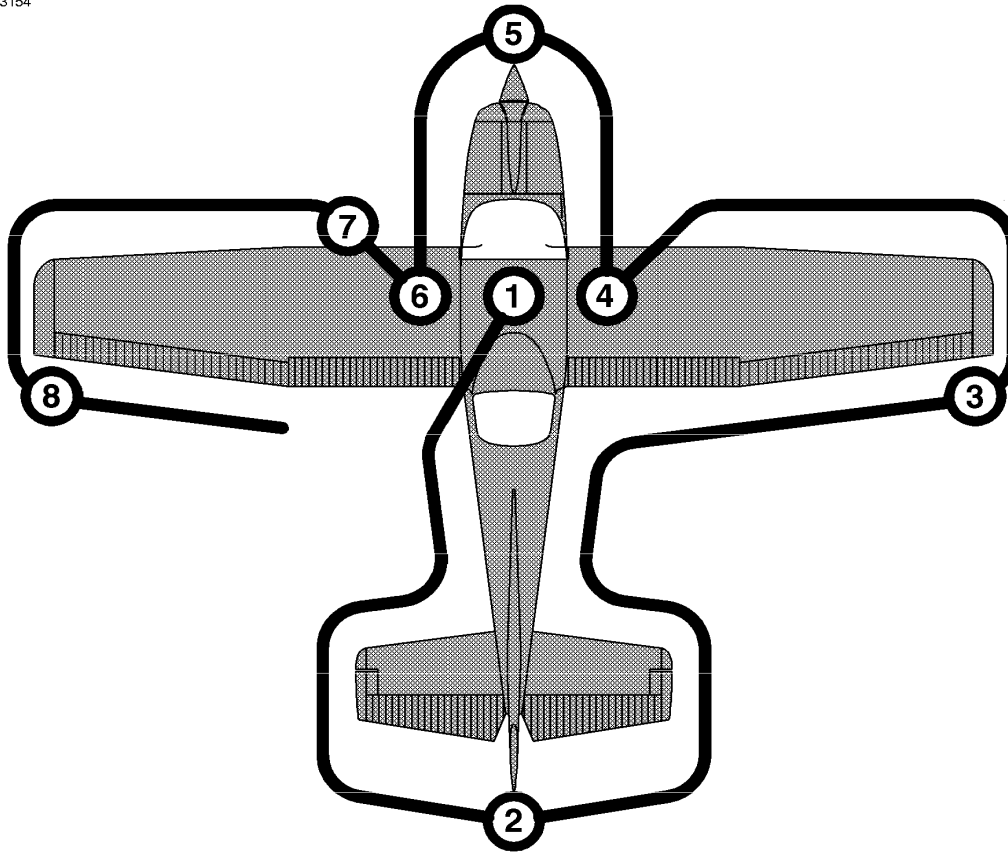

NOTE

Visually check airplane for general condition during walk-around inspection. Airplane should be parked in a normal ground attitude (refer to Figure 1-1) to make sure that fuel drain valves allow for accurate sampling. Use of the refueling steps and assist handles will simplify access to the upper wing surfaces for visual checks and refueling operations. In cold weather, remove even small accumulations of frost, ice or snow from wing, tail and control surfaces. Also, make sure that control surfaces contain no internal accumulations of ice or debris. Prior to flight, check that pitot heater is warm to touch within 30 seconds with battery and pitot heat switches on. If a night flight is planned, check operation of all lights, and make sure a flashlight is available.

Figure 4-1

PREFLIGHT INSPECTION (Continued)

① CABIN

1. Pitot Tube Cover - REMOVE (check for pitot blockage)
2. Pilot's Operating Handbook - ACCESSIBLE TO PILOT
3. Garmin G1000 Cockpit Reference Guide - ACCESSIBLE TO PILOT
4. Airplane Weight and Balance - CHECKED
5. Parking Brake - SET
6. Control Wheel Lock - REMOVE

WARNING

WHEN THE MASTER SWITCH IS ON, USING AN EXTERNAL POWER SOURCE, OR MANUALLY ROTATING THE PROPELLER, TREAT THE PROPELLER AS IF THE MAGNETOS SWITCH WERE ON. DO NOT STAND, NOR ALLOW ANYONE ELSE TO STAND, WITHIN THE ARC OF THE PROPELLER SINCE A LOOSE OR BROKEN WIRE, OR A COMPONENT MALFUNCTION, COULD CAUSE THE ENGINE TO START.

7. MAGNETOS Switch - OFF
8. AVIONICS Switch (BUS 1 and BUS 2) - OFF
9. MASTER Switch (ALT and BAT) - ON
10. Primary Flight Display (PFD) - CHECK (verify PFD is ON)
11. FUEL QTY (L and R) - CHECK
12. LOW FUEL L and LOW FUEL R Annunciators - CHECK (verify annunciators are not shown on PFD)
13. OIL PRESSURE Annunciator - CHECK (verify annunciator is shown)
14. LOW VACUUM Annunciator - CHECK (verify annunciator is shown)
15. AVIONICS Switch (BUS 1) - ON
16. Forward Avionics Fan - CHECK (verify fan is heard)

(Continued Next Page)

PREFLIGHT INSPECTION (Continued)

① **CABIN** (Continued)

17. AVIONICS Switch (BUS 1) - OFF
18. AVIONICS Switch (BUS 2) - ON
19. Aft Avionics Fan - CHECK (verify fan is heard)
20. AVIONICS Switch (BUS 2) - OFF
21. PITOT HEAT Switch - ON (carefully check that pitot tube is warm to the touch within 30 seconds)
22. PITOT HEAT Switch - OFF
23. Stall Warning System - CHECK (gently move the stall vane upward and verify that the stall warning horn is heard)
24. LOW VOLTS Annunciator - CHECK (verify annunciator is shown)
25. MASTER Switch (ALT and BAT) - OFF
26. Elevator and Rudder Trim Controls - TAKEOFF position
27. FUEL SELECTOR Valve - BOTH
28. ALT STATIC AIR Valve - OFF (push full in)
29. Fire Extinguisher - CHECK (verify gage pointer in green arc)

② **EMPENNAGE**

1. Baggage Compartment Door - CHECK (lock with key)
2. Rudder Gust Lock (if installed) - REMOVE
3. Tail Tiedown - DISCONNECT
4. Control Surfaces - CHECK (freedom of movement and security)
5. Trim Tabs - CHECK (security)
6. Antennas - CHECK (security of attachment and general condition)

③ **RIGHT WING Trailing Edge**

1. Flap - CHECK (security and condition)
2. Aileron - CHECK (freedom of movement and security)

(Continued Next Page)

PREFLIGHT INSPECTION (Continued)

④ RIGHT WING

1. Wing Tiedown - DISCONNECT
2. Fuel Tank Vent Opening - CHECK (verify opening is clear)
3. Main Wheel Tire - CHECK (proper inflation and general condition (weather checks, tread depth and wear, etc.))
4. Fuel Tank Sump Quick Drain Valves - DRAIN
Drain at least a cupful of fuel (using sampler cup) from each sump location to check for water, sediment, and proper fuel grade before each flight and after each refueling. If water is observed, take further samples until clear and then gently rock wings and lower tail to the ground to move any additional contaminants to the sampling points. Take repeated samples from **all** fuel drain points until **all** contamination has been removed. If contaminants are still present, refer to WARNING below and do not fly airplane.

NOTE

Collect all sampled fuel in a safe container. Dispose of the sampled fuel so that it does not cause a nuisance, hazard or damage to the environment.

WARNING

IF, AFTER REPEATED SAMPLING, EVIDENCE OF CONTAMINATION STILL EXISTS, THE AIRPLANE SHOULD NOT BE FLOWN. TANKS SHOULD BE DRAINED AND SYSTEM PURGED BY QUALIFIED MAINTENANCE PERSONNEL. ALL EVIDENCE OF CONTAMINATION MUST BE REMOVED BEFORE FURTHER FLIGHT.

5. Fuel Quantity - CHECK VISUALLY (for desired level)
6. Fuel Filler Cap - SECURE and VENT CLEAR

(Continued Next Page)

PREFLIGHT INSPECTION (Continued)

⑤ NOSE

1. Static Source Opening (right side of fuselage) - CHECK (verify opening is clear)
2. Fuel Strainer Quick Drain Valve (located on lower right side of engine cowling) - DRAIN

Drain at least a cupful of fuel (using sampler cup) from valve to check for water, sediment, and proper fuel grade before each flight and after each refueling. If water is observed, take further samples until clear and then gently rock wings and lower tail to the ground to move any additional contaminants to the sampling points. Take repeated samples from **all** fuel drain points, including the fuel return line and fuel selector, until **all** contamination has been removed. If contaminants are still present, refer to WARNING below and do not fly the airplane.

NOTE

Collect all sampled fuel in a safe container. Dispose of the sampled fuel so that it does not cause a nuisance, hazard, or damage to the environment.

WARNING

IF, AFTER REPEATED SAMPLING, EVIDENCE OF CONTAMINATION STILL EXISTS, THE AIRPLANE SHOULD NOT BE FLOWN. TANKS SHOULD BE DRAINED AND SYSTEM PURGED BY QUALIFIED MAINTENANCE PERSONNEL. ALL EVIDENCE OF CONTAMINATION MUST BE REMOVED BEFORE FURTHER FLIGHT.

3. Engine Cooling Air Inlets - CHECK (clear of obstructions)

(Continued Next Page)

PREFLIGHT INSPECTION (Continued)

⑤ **NOSE** (Continued)

- 4. Propeller and Spinner - CHECK (for nicks, security and no red oil leaks)

NOTE

Minor leaking of the blade seal area is possible on new propellers as the seals wear in. Any initial leakage will be visible as minor streaking on the blade or blades. Clean off oil residue and cycle propeller at least 5 times. Oil leakage should be reduced or completely stopped. If minor leaking continues after 20 hours of operation or increases remove propeller and have repaired.

- 5. Air Filter - CHECK (for restrictions by dust or other foreign matter)
- 6. Nosewheel Strut and Tire - CHECK (proper inflation of strut and general condition of tire (weather checks, tread depth and wear, etc.))
- 7. Engine Oil Dipstick/Filler Cap:
 - a. Oil level - CHECK
 - b. Dipstick/filler cap - SECURE

NOTE

Do not operate with less than 4 quarts. Fill to 9 quarts for extended flight.

- 8. Static Source Opening (left side of fuselage) - CHECK (verify opening is clear)

⑥ **LEFT WING Leading Edge**

- 1. Fuel Tank Vent Opening - CHECK (blockage)
- 2. Stall Warning Vane - CHECK (freedom of movement)
- 3. Landing/Taxi Light(s) - CHECK (condition and cleanliness of cover)

(Continued Next Page)

PREFLIGHT INSPECTION (Continued)

⑦ LEFT WING

1. Wing Tiedown - DISCONNECT
2. Fuel Quantity - CHECK VISUALLY (for desired level)
3. Fuel Filler Cap - SECURE and VENT CLEAR
4. Fuel Tank Sump Quick Drain Valves - DRAIN

Drain at least a cupful of fuel (using sampler cup) from each sump location to check for water, sediment, and proper fuel grade before each flight and after each refueling. If water is observed, take further samples until clear and then gently rock wings and lower tail to the ground to move any additional contaminants to the sampling points. Take repeated samples from **all** fuel drain points until **all** contamination has been removed. If contaminants are still present, refer to WARNING below and do not fly airplane.

NOTE

Collect all sampled fuel in a safe container. Dispose of the sampled fuel so that it does not cause a nuisance, hazard, or damage to the environment.

WARNING

IF, AFTER REPEATED SAMPLING, EVIDENCE OF CONTAMINATION STILL EXISTS, THE AIRPLANE SHOULD NOT BE FLOWN. TANKS SHOULD BE DRAINED AND SYSTEM PURGED BY QUALIFIED MAINTENANCE PERSONNEL. ALL EVIDENCE OF CONTAMINATION MUST BE REMOVED BEFORE FURTHER FLIGHT.

5. Main Wheel Tire - CHECK (proper inflation and general condition (weather checks, tread depth and wear, etc.))

⑧ LEFT WING Trailing Edge

1. Aileron - CHECK (freedom of movement and security)
2. Flap - CHECK (security and condition)

BEFORE STARTING ENGINE

1. Preflight Inspection - COMPLETE
2. Passenger Briefing - COMPLETE
3. Seats and Seat Belts - ADJUST and LOCK (verify inertia reel locking)
4. Brakes - TEST and SET
5. Circuit Breakers - CHECK IN
6. Electrical Equipment - OFF
7. AVIONICS Switch (BUS 1 and BUS 2) - OFF

CAUTION

THE AVIONICS SWITCH (BUS 1 AND BUS 2) MUST BE OFF DURING ENGINE START TO PREVENT POSSIBLE DAMAGE TO AVIONICS.

8. Cowl Flaps - OPEN
9. FUEL SELECTOR Valve - BOTH

STARTING ENGINE (With Battery)

1. Throttle Control - OPEN 1/4 INCH
2. Propeller Control - HIGH RPM (push full in)
3. Mixture Control - IDLE CUTOFF (pull full out)
4. STBY BATT Switch:
 - a. TEST - (hold for 20 seconds, verify that green TEST lamp does not go off)
 - b. ARM - (verify that PFD comes on)
5. Engine Indicating System - CHECK PARAMETERS (verify no red X's through ENGINE page indicators)
6. BUS E Volts - CHECK (verify 24 VOLTS minimum shown)
7. M BUS Volts - CHECK (verify 1.5 VOLTS or less shown)
8. BATT S Amps - CHECK (verify discharge shown (negative))
9. STBY BATT Annunciator - CHECK (verify annunciator is shown)
10. Propeller Area - CLEAR (verify that all people and equipment are at a safe distance from the propeller)
11. MASTER Switch (ALT and BAT) - ON
12. BEACON Light Switch - ON

NOTE

If engine is warm, omit priming procedure steps 13 thru 15 below.

13. FUEL PUMP Switch - ON
14. Mixture Control - SET to FULL RICH (full forward) until stable fuel flow is indicated (approximately 3 to 5 seconds), then set to IDLE CUTOFF (full aft) position.
15. FUEL PUMP Switch - OFF
16. MAGNETOS Switch - START (release when engine starts)
17. Mixture Control - ADVANCE SMOOTHLY TO RICH (when engine starts)

NOTE

If the engine is primed too much (flooded), place the mixture control in the IDLE CUTOFF position, open the throttle control 1/2 to full, and engage the starter motor (START). When the engine starts, advance the mixture control to the FULL RICH position and retard the throttle control promptly.

(Continued Next Page)

STARTING ENGINE (With Battery) (Continued)

18. Oil Pressure - CHECK (verify that oil pressure increases into the GREEN BAND range in 30 to 60 seconds)
19. AMPS (M BATT and BATT S) - CHECK (verify charge shown (positive))
20. LOW VOLTS Annunciator - CHECK (verify annunciator is not shown)
21. NAV Light Switch - ON as required
22. AVIONICS Switch (BUS 1 and BUS 2) - ON

STARTING ENGINE (With External Power)

1. Throttle Control - OPEN 1/4 INCH
2. Propeller Control - HIGH RPM (push full in)
3. Mixture Control - IDLE CUTOFF (pull full out)
4. STBY BATT Switch:
 - a. TEST - (hold for 20 seconds, verify green TEST lamp does not go off)
 - b. ARM - (verify that PFD comes on)
5. Engine Indication System - CHECK PARAMETERS (verify no red X's through ENGINE page indicators)
6. BUS E Volts - CHECK (verify 24 VOLTS minimum shown)
7. M BUS Volts - CHECK (verify 1.5 VOLTS or less shown)
8. BATT S Amps - CHECK (verify discharge shown (negative))
9. STBY BATT Annunciator - CHECK (verify annunciator is shown)
10. AVIONICS Switch (BUS 1 and BUS 2) - OFF
11. MASTER Switch (ALT and BAT) - OFF
12. Propeller Area - CLEAR (verify that all people and equipment are at a safe distance from the propeller)
13. External Power - CONNECT (to ground power receptacle)
14. MASTER Switch (ALT and BAT) - ON
15. BEACON Light Switch - ON
16. M BUS VOLTS - CHECK (verify that approximately 28 VOLTS is shown)

NOTE

If engine is warm, omit priming procedure steps 17 thru 19 below.

17. FUEL PUMP Switch - ON

(Continued Next Page)

STARTING ENGINE (With External Power) (Continued)

18. Mixture Control - SET to FULL RICH (full forward) until stable fuel flow is indicated (approximately 3 to 5 seconds), then set to IDLE CUTOFF (full aft) position.
19. FUEL PUMP Switch - OFF
20. MAGNETOS Switch - START (release when engine starts)
21. Mixture Control - ADVANCE SMOOTHLY TO RICH (when engine starts)

NOTE

If the engine is primed too much (flooded), place the mixture control in the IDLE CUTOFF position, open the throttle control 1/2 to full, and engage the starter motor (START). When the engine starts, advance the mixture control to the FULL RICH position and retard the throttle control promptly.

22. Oil Pressure - CHECK (verify oil pressure increases into the GREEN BAND range in 30 to 60 seconds)
23. Power - REDUCE TO IDLE
24. External Power - DISCONNECT FROM GROUND POWER (latch external power receptacle door)
25. Power - INCREASE (to approximately 1500 RPM for several minutes to charge battery)
26. AMPS (M BATT and BATT S) - CHECK (verify charge shown (positive))
27. LOW VOLTS Annunciator - CHECK (verify annunciator is not shown)
28. Internal Power - CHECK
 - a. MASTER Switch (ALT) - OFF
 - b. TAXI and LAND Light Switches - ON
 - c. Throttle Control - REDUCE TO IDLE
 - d. MASTER Switch (ALT and BAT) - ON
 - e. Throttle Control - INCREASE (to approximately 1500 RPM)
 - f. M BATT Ammeter - CHECK (verify battery charging, amps positive)
 - g. LOW VOLTS Annunciator - CHECK (verify annunciator is not shown)

(Continued Next Page)

STARTING ENGINE (With External Power) (Continued)

WARNING

IF M BATT AMMETER DOES NOT SHOW POSITIVE CHARGE (+ AMPS), OR LOW VOLTS ANNUNCIATOR DOES NOT GO OFF, REMOVE THE BATTERY FROM THE AIRPLANE AND SERVICE OR REPLACE THE BATTERY BEFORE FLIGHT.

29. NAV Light Switch - ON (as required)
30. AVIONICS Switch (BUS 1 and BUS 2) - ON

BEFORE TAKEOFF

1. Parking Brake - SET
2. Pilot and Passenger Seat Backs - MOST UPRIGHT POSITION
3. Seats and Seat Belts - CHECK SECURE
4. Cabin Doors - CLOSED and LOCKED
5. Flight Controls - FREE and CORRECT
6. Flight Instruments (PFD) - CHECK (no red X's)
7. Altimeters:
 - a. PFD (BARO) - SET
 - b. Standby Altimeter - SET
8. ALT SEL - SET
9. Standby Flight Instruments - CHECK
10. Fuel Quantity - CHECK (verify level is correct)

NOTE

Flight is not recommended when both fuel quantity indicators are in the yellow band range.

11. Mixture Control - RICH
12. FUEL SELECTOR Valve - SET BOTH
- 13. Autopilot - ENGAGE (push AP button on either PFD or MFD bezel)
- 14. Flight Controls - CHECK (verify autopilot can be overpowered in both pitch and roll axes)

(Continued Next Page)

BEFORE TAKEOFF (Continued)

15. A/P TRIM DISC Button - PRESS (verify autopilot disengages and aural alert is heard)
16. Flight Director - OFF (push FD button on either PFD or MFD bezel)
17. Elevator and Rudder Trim Controls - SET FOR TAKEOFF
18. Throttle Control - 1800 RPM
 - a. MAGNETOS Switch - CHECK (RPM drop should not exceed 175 RPM on either magneto or 50 RPM differential between magnetos)
 - b. Propeller Control - CYCLE (from high to low RPM; return to high RPM) (push full in)
 - c. VAC Indicator - CHECK
 - d. Engine Indicators - CHECK
 - e. Ammeters and Voltmeters - CHECK
19. Annunciators - CHECK (verify no annunciators are shown)
20. Throttle Control - CHECK IDLE
21. Throttle Control - 1000 RPM or LESS
22. Throttle Control Friction Lock - ADJUST
23. COM Frequency(s) - SET
24. NAV Frequency(s) - SET
25. FMS/GPS Flight Plan - AS DESIRED

NOTE

Check GPS availability on AUX-GPS STATUS page. No annunciation is provided for loss of GPS2.

26. XPDR - SET

(Continued Next Page)

BEFORE TAKEOFF (Continued)

27. CDI Softkey - SELECT NAV SOURCE

CAUTION

THE G1000 HSI SHOWS A COURSE DEVIATION INDICATOR FOR THE SELECTED GPS, NAV 1 OR NAV 2 NAVIGATION SOURCE. THE G1000 HSI DOES NOT PROVIDE A WARNING FLAG WHEN A VALID NAVIGATION SIGNAL IS NOT BEING SUPPLIED TO THE INDICATOR. WHEN A VALID NAVIGATION SIGNAL IS NOT BEING SUPPLIED, THE COURSE DEVIATION BAR (D-BAR) PART OF THE INDICATOR IS NOT SHOWN ON THE HSI COMPASS CARD. THE MISSING D-BAR IS CONSIDERED TO BE THE WARNING FLAG.

WARNING

WHEN THE AUTOPILOT IS ENGAGED IN NAV, APR OR BC OPERATING MODES, IF THE HSI NAVIGATION SOURCE IS CHANGED MANUALLY, USING THE CDI SOFTKEY, THE CHANGE WILL INTERRUPT THE NAVIGATION SIGNAL TO THE AUTOPILOT AND WILL CAUSE THE AUTOPILOT TO REVERT TO ROL MODE OPERATION. NO AURAL ALERT WILL BE PROVIDED. IN ROL MODE, THE AUTOPILOT WILL ONLY KEEP THE WINGS LEVEL AND WILL NOT CORRECT THE AIRPLANE HEADING OR COURSE. SET THE HDG BUG TO THE CORRECT HEADING AND SELECT THE CORRECT NAVIGATION SOURCE ON THE HSI, USING THE CDI SOFTKEY, BEFORE ENGAGING THE AUTOPILOT IN ANY OTHER OPERATING MODE.

- 28. CABIN PWR 12V Switch - OFF
- 29. Wing Flaps - UP - 20° (10° preferred)
- 30. Cowl Flaps - OPEN
- 31. Cabin Windows - CLOSED and LOCKED
- 32. STROBE Light Switch - ON
- 33. Brakes - RELEASE

TAKEOFF

NORMAL TAKEOFF

1. Wing Flaps - UP - 20° (10° preferred)
2. Throttle Control - FULL (push full in)
3. Propeller Control - 2400 RPM
4. Mixture Control - RICH (above 5000 feet pressure altitude, lean for maximum RPM)
5. Elevator Control - LIFT NOSEWHEEL (at 50 - 60 KIAS)
6. Climb Airspeed - 70 KIAS (FLAPS 20°)
80 KIAS (FLAPS UP)
7. Wing Flaps - RETRACT (at safe altitude)

SHORT FIELD TAKEOFF

1. Wing Flaps - 20°
2. Brakes - APPLY
3. Throttle Control - FULL (push full in)
4. Propeller Control - 2400 RPM
5. Mixture Control - RICH (above 5000 feet pressure altitude, lean for maximum RPM)
6. Brakes - RELEASE
7. Elevator Control - SLIGHTLY TAIL LOW
8. Climb Airspeed - 58 KIAS (until all obstacles are cleared)
9. Wing Flaps - RETRACT SLOWLY (when airspeed is more than 70 KIAS)

ENROUTE CLIMB

NORMAL CLIMB

1. Airspeed - 85 - 95 KIAS
2. Throttle Control - 23 in.hg. or FULL (if less than 23 in.hg.)
3. Propeller Control - 2400 RPM
4. Mixture Control - 15 GPH or FULL RICH (if less than 15 GPH)
5. FUEL SELECTOR Valve - BOTH
6. Cowl Flaps - OPEN (as required)

MAXIMUM PERFORMANCE CLIMB

1. Airspeed -80 KIAS at sea level
74 KIAS at 10,000 feet
2. Throttle Control - FULL (push full in)
3. Propeller Control - 2400 RPM
4. Mixture Control - FULL RICH (or SET to Maximum Power Fuel Flow Placard value for altitude in Amplified Normal Procedures)
5. FUEL SELECTOR Valve - BOTH
6. Cowl Flaps - OPEN

CRUISE

1. Power - 15 - 23 in.hg. at 2000 - 2400 RPM (no more than 80% power recommended)
2. Elevator and Rudder Trim Controls - ADJUST
3. Mixture Control - LEAN (for desired performance or economy)
4. Cowl Flaps - CLOSED
5. FMS/GPS - REVIEW and BRIEF (OBS/SUSP softkey operation for holding pattern procedure (IFR))

DESCENT

1. Power - AS DESIRED
2. Mixture - ADJUST (if necessary to make engine run smoothly)
3. Cowl Flaps - CLOSED
4. Altimeters:
 - a. PFD (BARO) - SET
 - b. Standby Altimeter - SET
5. ALT SEL - SET
6. CDI Softkey - SELECT NAV SOURCE
7. FMS/GPS - REVIEW and BRIEF (OBS/SUSP softkey operation for holding pattern procedure (IFR))

CAUTION

THE G1000 HSI SHOWS A COURSE DEVIATION INDICATOR FOR THE SELECTED GPS, NAV 1 OR NAV 2 NAVIGATION SOURCE. THE G1000 HSI DOES NOT PROVIDE A WARNING FLAG WHEN A VALID NAVIGATION SIGNAL IS NOT BEING SUPPLIED TO THE INDICATOR. WHEN A VALID NAVIGATION SIGNAL IS NOT BEING SUPPLIED, THE COURSE DEVIATION BAR (D-BAR) PART OF THE INDICATOR IS NOT SHOWN ON THE HSI COMPASS CARD. THE MISSING D-BAR IS CONSIDERED TO BE THE WARNING FLAG.

WARNING

WHEN THE AUTOPILOT IS ENGAGED IN NAV, APR OR BC OPERATING MODES, IF THE HSI NAVIGATION SOURCE IS CHANGED MANUALLY, USING THE CDI SOFTKEY, THE CHANGE WILL INTERRUPT THE NAVIGATION SIGNAL TO THE AUTOPILOT AND WILL CAUSE THE AUTOPILOT TO REVERT TO ROL MODE OPERATION. NO AURAL ALERT WILL BE PROVIDED. IN ROL MODE, THE AUTOPILOT WILL ONLY KEEP THE WINGS LEVEL AND WILL NOT CORRECT THE AIRPLANE HEADING OR COURSE. SET THE HDG BUG TO THE CORRECT HEADING AND SELECT THE CORRECT NAVIGATION SOURCE ON THE HSI, USING THE CDI SOFTKEY, BEFORE ENGAGING THE AUTOPILOT IN ANY OTHER OPERATING MODE.

8. FUEL SELECTOR Valve - BOTH
9. Wing Flaps - AS DESIRED (UP - 10° below 140 KIAS)
(10° - 20° below 120 KIAS)
(20° - FULL below 100 KIAS)

BEFORE LANDING

1. Pilot and Passenger Seat Backs - MOST UPRIGHT POSITION
2. Seats and Seat Belts - SECURED and LOCKED
3. FUEL SELECTOR Valve - BOTH
4. Mixture Control - RICH
5. Propeller Control - HIGH RPM (push full in)
6. LAND and TAXI Light Switches - ON
7. Autopilot - OFF
8. CABIN PWR 12V Switch - OFF

LANDING

NORMAL LANDING

1. Airspeed - 70 - 80 KIAS (Flaps UP)
2. Wing Flaps - AS DESIRED (UP - 10° below 140 KIAS)
(10° - 20° below 120 KIAS)
(20° - FULL below 100 KIAS)
3. Airspeed - 60 - 70 KIAS (Flaps FULL)
4. Elevator and Rudder Trim Controls - ADJUST
5. Touchdown - MAIN WHEELS FIRST
6. Landing Roll - LOWER NOSEWHEEL GENTLY
7. Braking - MINIMUM REQUIRED

SHORT FIELD LANDING

1. Airspeed - 70 - 80 KIAS (Flaps UP)
2. Wing Flaps - FULL (below 100 KIAS)
3. Airspeed - 60 KIAS (until flare)
4. Elevator and Rudder Trim Controls - ADJUST
5. Power - REDUCE TO IDLE (as obstacle is cleared)
6. Touchdown - MAIN WHEELS FIRST
7. Brakes - APPLY HEAVILY
8. Wing Flaps - UP

(Continued Next Page)

LANDING (Continued)

BALKED LANDING

1. Throttle Control - FULL (push full in) and 2400 RPM
2. Wing Flaps - RETRACT to 20°
3. Climb Speed - 55 KIAS
4. Wing Flaps - RETRACT SLOWLY (after reaching a safe altitude and 70 KIAS)
5. Cowl Flaps - OPEN

AFTER LANDING

1. Wing Flaps - UP
2. Cowl Flaps - OPEN

SECURING AIRPLANE

1. Parking Brake - SET
2. Throttle Control - IDLE (pull full out)
3. Electrical Equipment - OFF
4. AVIONICS Switch (BUS 1 and BUS 2) - OFF
5. Mixture Control - IDLE CUTOFF (pull full out)
6. MAGNETOS Switch - OFF
7. MASTER Switch (ALT and BAT) - OFF
8. STBY BATT Switch - OFF
9. Control Lock - INSTALL
10. FUEL SELECTOR Valve - LEFT or RIGHT (to prevent crossfeeding between tanks)

AMPLIFIED NORMAL PROCEDURES

PREFLIGHT INSPECTION

The preflight inspection, described in Figure 4-1 and adjacent checklist, is required prior to each flight. If the airplane has been in extended storage, has had recent major maintenance, or has been operated from rough runways, a more extensive exterior inspection is recommended.

Before every flight, check the condition of main and nose landing gear tires. Keep tires inflated to the pressure specified in Section 8, Airplane Handling, Service And Maintenance. Examine tire sidewalls for patterns of shallow cracks called weather checks. These cracks are evidence of tire deterioration caused by age, improper storage, or prolonged exposure to weather. Check the tread of the tire for depth, wear, and cuts. Replace the tire if fibers are visible.

After major maintenance has been performed, the flight and trim tab controls should be double checked for free and correct movement and security. The security of all inspection plates on the airplane should be checked following periodic inspections. If the airplane has been waxed or polished, check the external static pressure source hole for stoppage.

If the airplane has been kept in a crowded hangar, it should be checked for dents and scratches on wings, fuselage, and tail surfaces, damage to navigation, strobe lights, and avionics antennas. Check for damage to the nosewheel steering system, the result of exceeding nosewheel turning limits while towing.

(Continued Next Page)

PREFLIGHT INSPECTION (Continued)

Outside storage for long periods may result in dust and dirt accumulation on the induction air filter, obstructions in airspeed system lines, water contaminants in fuel tanks, and insect/bird/rodent nests in any opening. If any water is detected in the fuel system, the fuel tank sump quick drain valves, fuel return line quick drain valve, and fuel strainer quick drain valve should all be thoroughly drained again. The wings should then be gently rocked and the tail lowered to the ground to move any further contaminants to the sampling points. Repeated samples should then be taken at **all** quick drain points until **all** contamination has been removed. If, after repeated sampling, evidence of contamination still exists, the fuel tanks should be completely drained and the fuel system cleaned.

If the airplane has been stored outside in windy or gusty areas, or tied down adjacent to taxiing airplanes, special attention should be paid to control surface stops, hinges, and brackets to detect the presence of potential wind damage.

If the airplane has been operated from muddy fields or in snow or slush, check the main and nose gear wheel fairings for obstructions and cleanliness. Operation from a gravel or cinder field will require extra attention to propeller tips and abrasion on leading edges of the horizontal tail. Stone damage to the propeller can seriously reduce the fatigue life of the blades.

Airplanes that are operated from rough fields, especially at high altitudes, are subjected to abnormal landing gear abuse. Frequently check all components of the landing gear, shock strut, tires, and brakes. If the shock strut is insufficiently extended, undue landing and taxi loads will be subjected to the airplane structure.

To prevent loss of fuel in flight, make sure the fuel tank filler caps are tightly sealed after any fuel system check or servicing. Fuel system vents should also be inspected for obstructions, ice or water, especially after exposure to cold, wet weather.

STARTING ENGINE

In cooler weather, the engine compartment temperature drops off rapidly following engine shutdown and the injector nozzle lines remain nearly full of fuel.

In warmer weather, engine compartment temperatures may increase rapidly following engine shutdown, and fuel in the lines will vaporize and escape into the intake manifold. Hot weather starting procedures depend considerably on how soon the next engine start is attempted. Within the first 20 to 30 minutes after shutdown, the fuel manifold is adequately primed and the empty injector nozzle lines will fill before the engine dies. However, after approximately 30 minutes, the vaporized fuel in the manifold will have nearly dissipated and some slight priming could be required to refill the nozzle lines and keep the engine running after the initial start. Starting a hot engine is facilitated by advancing the mixture control promptly to 1/3 open when the engine starts, and then smoothly to full rich as power develops.

If the engine does not continue to run, set the FUEL PUMP switch to the ON position temporarily and adjust the throttle and/or mixture as necessary to keep the engine running. In the event of over priming or flooding, set the FUEL PUMP switch to OFF, open the throttle from 1/2 to full open, and continue cranking with the mixture in the idle CUTOFF position (pull full out). When the engine fires, smoothly advance the mixture control to full rich and retard the throttle to desired idle speed.

If the engine is under primed (most likely in cold weather with a cold engine), it will not start at all, and additional priming will be necessary.

After starting, if the oil pressure gage does not begin to show pressure within 30 seconds in warmer temperatures and approximately one minute in very cold weather, stop the engine and find the cause before continued operation. Lack of oil pressure can cause serious engine damage.

NOTE

Additional details concerning cold weather starting and operation may be found under COLD WEATHER OPERATION paragraphs in this section.

(Continued Next Page)

STARTING ENGINE (Continued)

RECOMMENDED STARTER DUTY CYCLE

Operate the starter motor for 10 seconds followed by a 20 second cool down period. This cycle can be repeated two additional times, followed by a ten minute cool down period before resuming cranking. After cool down, operate the starter motor again, three cycles of 10 seconds followed by 20 seconds of cool down. If the engine still does not start, try to find the cause.

LEANING FOR GROUND OPERATIONS

For all ground operations, after starting the engine and when the engine is running smoothly:

1. Set the throttle control to 1200 RPM.
2. Lean the mixture for maximum RPM.
3. Set the throttle control to an RPM appropriate for ground operations (800 to 1000 RPM recommended).

NOTE

If ground operation will be required after the BEFORE TAKEOFF checklist is completed, lean the mixture again (as described above) until ready for the TAKEOFF checklist.

(Continued Next Page)

TAXIING

When taxiing, it is important that speed and use of brakes be held to a minimum and that all controls be utilized (refer to Figure 4-2, Taxiing Diagram) to maintain directional control and balance.

Taxiing over loose gravel or cinders should be done at low engine speed to avoid abrasion and stone damage to the propeller tips.

NOTE

The LOW VOLTS annunciator may come on when the engine is operated at low RPM with a high load on the electrical system. If this is the case, the LOW VOLTS annunciator will go off when the engine is run at higher RPM to provide greater alternator system output. Verify that the M BATT AMPS indication shows positive (charging) current at the higher RPM.

(Continued Next Page)

TAXIING (Continued)

TAXIING DIAGRAM

B3155

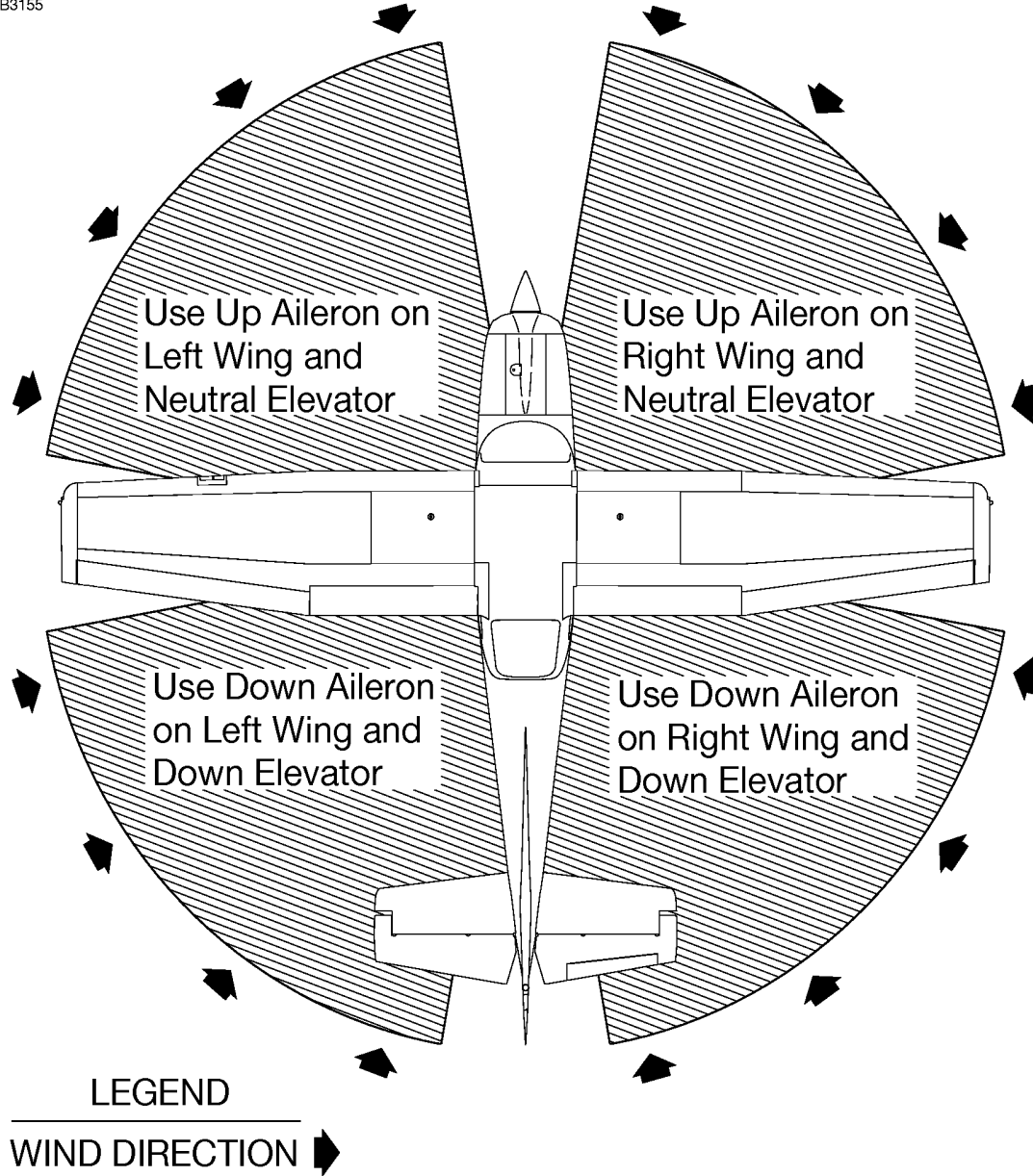

NOTE

Strong quartering tail winds require caution. Avoid sudden bursts of the throttle and sharp braking when the airplane is in this attitude. Use the steerable nosewheel and rudder to maintain direction.

Figure 4-2

BEFORE TAKEOFF

WARM UP

If the engine idles (approximately 650 RPM) and accelerates smoothly, the engine is warm enough for takeoff. Since the engine is closely cowled for efficient in-flight engine cooling, the cowl flaps should be open and the airplane pointed into the wind to avoid overheating during prolonged engine operation on the ground. Long periods of idling may cause fouled spark plugs.

MAGNETO CHECK

The magneto check must be made at 1800 RPM. Turn the MAGNETOS switch from the BOTH position to the R position. Note the new RPM, then turn the MAGNETOS switch back to the BOTH position to clear the spark plugs. Turn the MAGNETOS switch to the L position, note the new RPM, then turn the switch back to the BOTH position. RPM decrease should not be more than 175 RPM on either magneto or be greater than 50 RPM differential between magnetos. If there is a doubt concerning operation of the ignition system, RPM checks at higher engine speeds will usually confirm whether a deficiency exists.

No RPM drop may indicate a faulty ground to one magneto or magneto timing set in advance of the angle specified.

ALTERNATOR CHECK

Make sure that both the alternator and alternator control unit are operating properly before night or instrument flight, or flights where electrical power is essential. Check the electrical system during the MAGNETO check (1800 RPM) by setting all electrical equipment required for the flight to the ON position. When the alternator and alternator control unit are both operating properly, the ammeters will show zero or positive current (amps), the voltmeters should show between 27 to 29 volts, and no electrical system annunciators will appear. Reduce the electrical load before reducing engine speed so the battery will not discharge while the engine is at idle.

(Continued Next Page)

BEFORE TAKEOFF (Continued)

ELEVATOR TRIM

The elevator trim tab is in the takeoff position when the trim pointer is aligned with the index mark on the pedestal cover. Adjust the trim wheel during flight as necessary to make control wheel forces more neutral.

LANDING LIGHTS

It is recommended that only the taxi light be used to enhance the visibility of the airplane in the traffic pattern or enroute. This will extend the service life of the landing light.

TAKEOFF

POWER CHECK

It is important to check full throttle engine operation early in the takeoff roll. Any sign of rough engine operation or sluggish engine acceleration is good cause for discontinuing the takeoff. If this occurs, you are justified in making a thorough full throttle static run-up before another takeoff is attempted. The engine should run smoothly and turn approximately 2350 - 2400 RPM.

Full throttle run-ups over loose gravel are especially harmful to propeller tips. When takeoffs must be made over a gravel surface, advance the throttle slowly. This allows the airplane to start rolling before high RPM is developed, and the gravel will be blown behind the propeller rather than pulled into it.

Prior to takeoff from fields above 5000 feet pressure elevation, the mixture should be leaned to give maximum RPM at full throttle, with the airplane not moving. This mixture setting should provide a fuel flow that closely matches that shown on the Maximum Power Fuel Flow placard.

After full throttle is applied, adjust the throttle friction lock clockwise to prevent the throttle from moving back from a maximum power position. Similar friction lock adjustments should be made as required in other flight conditions to hold the throttle setting.

(Continued Next Page)

TAKEOFF (Continued)

WING FLAP SETTINGS

Normal takeoffs use wing flaps UP - 20° (10° preferred). Using 20° wing flaps reduces the ground roll and total distance over an obstacle by approximately 20 percent. **Flap deflections greater than 20° are not approved for takeoff.** If 20° wing flaps are used for takeoff, the flaps should stay at 20° until all obstacles are cleared and a safe flap retraction speed of 70 KIAS is reached. For a short field, 20° wing flaps and an obstacle clearance speed of 60 KIAS should be used.

Soft or rough field takeoffs are performed with 20° flaps by lifting the airplane off the ground as soon as practical in a slightly tail low attitude. If no obstacles are ahead, the airplane should be leveled off immediately to accelerate to a higher climb speed. When departing a soft field with an aft C.G. loading, the elevator trim control should be adjusted towards the nose down direction to give comfortable control wheel forces during the initial climb.

CROSSWIND TAKEOFF

Takeoffs under strong crosswind conditions normally are performed with the minimum flap setting necessary for the field length, to minimize the drift angle immediately after takeoff. With the ailerons partially deflected into the wind, the airplane is accelerated to a speed slightly higher than normal, then the elevator control is used to quickly, but carefully, lift the airplane off the ground and to prevent possible settling back to the runway while drifting. When clear of the ground, make a coordinated turn into the wind to correct for drift.

ENROUTE CLIMB

Normal enroute climbs are performed with flaps up, at 23 in.hg. manifold pressure or full throttle, whichever is less, 2400 RPM, and 85 to 95 KIAS for the best combination of performance, visibility, engine cooling, economy and passenger comfort (due to lower noise level). The mixture should be full rich during climb at altitudes up to 5000 feet pressure altitude.

If it is necessary to climb more rapidly to clear mountains or reach favorable winds at higher altitudes, the best rate of climb speed should be used with MCP. This speed is 80 KIAS at sea level, decreasing to 74 KIAS at 10,000 feet. For maximum power climb use full throttle and 2400 RPM with the mixture set in accordance with the Maximum Power Fuel Flow placard.

If an obstruction dictates the use of a steep climb angle, the best angle of climb speed should be used with flaps up and maximum power. This speed is 64 KIAS at sea level, increasing to 68 KIAS at 20,000 feet. This type of climb should be of the minimum duration and engine temperatures should be carefully monitored due to the low climb speed.

For maximum power, the mixture should be set in accordance with the Maximum Power Fuel Flow placard. The fuel flow values on the placard are minimum fuel flows.

MAXIMUM POWER FUEL FLOW	
ALTITUDE	FUEL FLOW
S.L.	20.5 GPH
2000 Feet	19.0 GPH
4000 Feet	17.5 GPH
6000 Feet	16.5 GPH
8000 Feet	15.5 GPH
10,000 Feet	14.5 GPH
12,000 Feet	13.5 GPH

CRUISE

Normal cruise is performed between 55% and 80% of the rated MCP. However, any power setting within the green arc ranges on the manifold pressure indicator and tachometer may be used. The power setting and corresponding fuel consumption for various altitudes can be determined by using the data in Section 5.

NOTE

Cruise flight should use 75% power as much as possible until the engine has operated for a total of 50 hours or oil consumption has stabilized. Operation at this higher power will ensure proper seating of the piston rings and is applicable to new engines, and engines in service following cylinder replacement or top overhaul of one or more cylinders.

The Cruise Performance charts in Section 5 provide the pilot with flight planning information for the Model 182T in still air with speed fairings installed. Power, altitude, and winds determine the time and fuel needed to complete any flight.

The Cruise Performance Table, Figure 4-3, shows the true airspeed and nautical miles per gallon during cruise for various altitudes and percent powers, and is based on standard conditions and zero wind. This table should be used as a guide, along with the available winds aloft information, to determine the most favorable altitude and power setting for a given trip. The selection of cruise altitude on the basis of the most favorable wind conditions and the use of low power settings are significant factors that should be considered on every trip to reduce fuel consumption.

In addition to power settings, proper leaning techniques also contribute to greater range and are figured into cruise performance tables. To achieve the recommended lean mixture fuel consumption figures shown in Section 5, the mixture should be leaned using the Exhaust Gas Temperature (EGT) indicator as noted.

(Continued Next Page)

CRUISE (Continued)

For reduced noise levels, it is desirable to select the lowest RPM in the green arc range for a given percent power that will provide smooth engine operation. The cowl flaps should be opened, if necessary, to maintain the cylinder head temperature at approximately two-thirds of the normal operating range (green band).

CRUISE PERFORMANCE TABLE

CONDITIONS:

Standard Conditions

Zero Wind

ALTITUDE FEET	80% POWER		75% POWER		65% POWER		55% POWER	
	KTAS	NMPG	KTAS	NMPG	KTAS	NMPG	KTAS	NMPG
4000	141	10.2	138	10.6	129	11.3	118	11.8
6000	144	10.4	140	10.8	131	11.4	120	12.0
8000	---	---	142	11.0	133	11.6	122	12.1
10,000	---	---	---	---	135	11.8	124	12.3

Figure 4-3

The Cruise Performance charts in Section 5 provide the pilot with cruise performance at maximum gross weight. When normal cruise is performed at reduced weights there is an increase in true airspeed. During normal cruise at power settings between 55% and 80%, the true airspeed will increase approximately 1 knot for every 150 pounds below maximum gross weight. During normal cruise at power settings below 70%, the true airspeed will increase approximately 1 knot for every 125 pounds below maximum gross weight.

The fuel injection system employed on this engine is considered to be non-icing. In the event that unusual conditions cause the intake air filter to become clogged or iced over, an alternate intake air door opens automatically for the most efficient use of either normal or alternate air, depending on the amount of filter blockage. Due to the lower intake pressure available through the alternate air door or a partially blocked filter, manifold pressure can decrease from a cruise power setting. This manifold pressure should be recovered by increasing the throttle setting or setting a higher RPM as necessary to maintain desired power.

(Continued Next Page)

CRUISE (Continued)

LEANING USING EXHAUST GAS TEMPERATURE (EGT)

The cruise performance data in this POH is based on the recommended lean mixture setting determined from the maximum or peak EGT at power settings of 80% MCP and lower. The 182T Nav III provides EGT indications for all (6) engine cylinders. The ability to monitor all cylinders is an aid in early identification and correction of fuel injection problems.

NOTE

All engine cylinders do not receive identical fuel/air mixtures (due to unequal intake pipe lengths, uneven intake air temperatures, fuel injection nozzle tolerances etc.). However, all cylinder EGTs should be within approximately 50°F of each other during normal operations. An EGT difference greater than 50°F between cylinders indicates that fuel injection system maintenance is necessary.

EGT is displayed on the EIS ENGINE and LEAN pages. The ENGINE page has a horizontal scale with a temperature indicator (inverted triangle) with a number representing the cylinder with the highest EGT.

The EIS LEAN page provides vertical bar graph displays showing EGT for all cylinders. The cylinder with the highest EGT is shown in cyan (light blue). The numerical value for the highest EGT is located below the bar. The EGT and Cylinder Head Temperature (CHT) value for any cylinder may be shown by using the CYL SLCT softkey to select the desired cylinder. After a short period without CYL SLCT softkey activity, automatic indication of the highest EGT and CHT will start again.

(Continued Next Page)

CRUISE (Continued)

LEANING USING EXHAUST GAS TEMPERATURE (EGT) (Continued)

To aid in leaning the mixture, push the ENGINE, LEAN and ASSIST softkeys, Δ PEAK °F will display below the EGT °F numerical value. Lean the mixture by slowly turning the mixture control knob in the counterclockwise direction while monitoring EGTs. As EGTs increase, continue to lean the mixture until the hottest (cyan) cylinder reaches peak EGT. This is identified by the EGT bar graph for that cylinder changing to cyan with a hollow bar at the top. Note the Δ PEAK °F and FFLOW GPH values for the first peaked cylinder. Peak EGT is represented by Δ PEAK 0°F, if Δ PEAK °F value is negative (-) the mixture can be on the lean side of peak. Enrichen the mixture by slowly turning the mixture control clockwise and monitor both fuel flow and EGTs until the leanest cylinder returns to peak EGT (Δ PEAK 0°F) or desired setting based on the Exhaust Gas Temperature (EGT) Table, Figure 4-4.

Δ PEAK °F values rich of peak will also be a negative (-) value (-50°F or -125°F). The lean assist system calculation is defined such that the peak EGT is the highest value and any lesser value is represented with a negative (-) value, whether on the lean or rich side of the peak.

NOTE

The 182T engine manufacturer, Textron Lycoming, has not approved operation of the engine at fuel flow rates (mixture settings) less than necessary to reach peak EGT in the leanest cylinder (the first cylinder to reach peak EGT). Use FULL RICH mixture when operating the engine above 80% power.

(Continued Next Page)

CRUISE (Continued)

LEANING USING EXHAUST GAS TEMPERATURE (EGT) (Continued)

EXHAUST GAS TEMPERATURE (EGT)

MIXTURE DESCRIPTION	EXHAUST GAS TEMPERATURE (EGT)
RECOMMENDED LEAN (Pilot's Operating Handbook)	50°F Rich of Peak EGT
BEST ECONOMY	Peak EGT
BEST POWER	125°F Rich of Peak EGT

Figure 4-4

Operation at peak EGT provides the best fuel economy. This results in approximately 4% greater range than shown in this POH accompanied by approximately a 3 knot decrease in speed.

Under some conditions, engine roughness may occur while operating at peak EGT. In this case, operate at the recommended lean mixture.

NOTE

- Any change in altitude or power setting will require a change in the recommended lean mixture setting and a recheck of the EGT setting.
- The EGT indicators take several seconds, after a mixture adjustment, to start to show EGT changes. Finding peak EGT and adjusting the mixture to the applicable setting should take approximately one minute when the adjustments are made carefully and accurately. Adjusting the mixture quickly is not recommended.

(Continued Next Page)

CRUISE (Continued)

FUEL SAVINGS PROCEDURES FOR NORMAL OPERATIONS

For best fuel economy during normal operations, the following procedures are recommended.

1. After engine start and for all ground operations, set the throttle to 1200 RPM and lean the mixture for maximum RPM. After leaning, set the throttle to the appropriate RPM for ground operations. Leave the mixture at this setting until beginning the BEFORE TAKEOFF checklist. After the BEFORE TAKEOFF checklist is complete, lean the mixture again as described above, until ready to perform the TAKEOFF checklist.
2. Adjust the mixture for placarded fuel flows during MCP climbs.
3. Lean the mixture at any altitude for RECOMMENDED LEAN or BEST ECONOMY fuel flows when using 80% or less power.

NOTE

Using the above recommended procedures can provide fuel savings in excess of 5% when compared to typical training operations at full rich mixture. In addition, the above procedures will minimize spark plug fouling since the reduction in fuel consumption results in a proportional reduction in tetraethyl lead passing through the engine.

(Continued Next Page)

CRUISE (Continued)

FUEL VAPOR PROCEDURES

The engine fuel system can cause fuel vapor formation on the ground during warm weather. This will generally occur when the outside ambient air temperature is above 80°F. Vapor formation may increase when the engine fuel flows are lower at idle and taxi engine speeds. The following procedures are recommended when engine idle speed and fuel flow fluctuations show that fuel vapor may be present:

1. With the mixture full rich, set the throttle at 1800 RPM to 2000 RPM. Maintain this power setting for 1 to 2 minutes or until smooth engine operation returns.
2. Retard the throttle to idle to verify normal engine operation.
3. Advance the throttle to 1200 RPM and lean the mixture as described under FUEL SAVINGS PROCEDURES FOR NORMAL OPERATIONS.
4. In addition to the above procedures, the auxiliary fuel pump may be turned ON with the mixture adjusted as required to aid vapor suppression during ground operations. The auxiliary fuel pump should be turned OFF prior to takeoff.
5. Just prior to TAKEOFF, apply full throttle for approximately 10 seconds to verify smooth engine operation for takeoff.

NOTE

When the engine is operated above 1800 RPM, the resulting increased fuel flow results in lower fuel temperatures throughout the engine fuel system. This increased flow purges the fuel vapor and the cooler fuel minimizes vapor formation.

(Continued Next Page)

CRUISE (Continued)

FUEL VAPOR PROCEDURES (Continued)

In addition to the previous procedures, the sections below should be reviewed, and where applicable, adhered to:

Section 3 -Take note of the excessive fuel vapor procedures in both the checklist and the amplified procedures sections.

Section 4 -Take note of the hot weather operational notes and procedures in both the checklist and the amplified procedures sections.

Section 7 -Take note of the altitude operational procedures and the section on auxiliary fuel pump operation.

STALLS

The stall characteristics are conventional and aural warning is provided by a stall warning horn which sounds between 5 and 10 knots above the stall in all configurations.

Power off stall speeds at maximum weight for both forward and aft C.G. positions are presented in Section 5.

LANDING

NORMAL LANDING

Normal landing approaches can be made with power on or power off with any flap setting within the flap airspeed limits. Surface winds and air turbulence are usually the primary factors in determining the most comfortable approach speeds. Steep slips with flap settings greater than 20° can cause a slight tendency for the elevator to oscillate under certain combinations of airspeed, sideslip angle, and center of gravity loadings.

Landing at slower speeds will result in shorter landing distances and minimum wear to tires and brakes. Power must be at idle as the main wheels touch the ground. The main wheels must touch the ground before the nosewheel. The nosewheel must be lowered to the runway carefully after the speed has diminished to avoid unnecessary nose gear loads. This procedure is very important for rough or soft field landings.

SHORT FIELD LANDING

For a short field landing in smooth air conditions, approach at 60 KIAS with FULL flaps using enough power to control the glide path. Slightly higher approach speeds should be used in turbulent air conditions. After all approach obstacles are cleared, smoothly reduce power and hold the approach speed by lowering the nose of the airplane. The main wheels must touch the ground before the nosewheel with power at idle. Immediately after the main wheels touch the ground, carefully lower the nosewheel and apply heavy braking as required. For maximum brake performance, retract the flaps, hold the control wheel full back, and apply maximum brake pressure without skidding the tires.

(Continued Next Page)

LANDING (Continued)

CROSSWIND LANDING

When landing in a strong crosswind, use the minimum flap setting required for the field length. If flap settings greater than 20° are used in sideslips with full rudder deflection, some elevator oscillation may be felt at normal approach speeds. However, this does not affect control of the airplane. Although the crab or combination method of drift correction may be used, the wing low method gives the best control. After touchdown, hold a straight course with the steerable nosewheel, with aileron deflection as applicable, and occasional braking if necessary.

The maximum allowable crosswind velocity is dependent upon pilot capability as well as airplane limitations. Operation in direct crosswinds of 15 knots has been demonstrated.

BALKED LANDING

In a balked landing (go-around) climb, reduce the flap setting to 20° immediately after full power is applied and climb at 55 KIAS. Above 5000 feet pressure altitude, lean the mixture to obtain maximum RPM. After clearing any obstacles, carefully retract the flaps and allow the airplane to accelerate to normal climb airspeed.

COLD WEATHER OPERATIONS

Special consideration should be given to the operation of the airplane fuel system during the winter season or prior to any flight in cold temperatures. Proper preflight draining of the fuel system is especially important and will eliminate any free water accumulation. The use of additives such as isopropyl alcohol or Diethylene Glycol Monomethyl Ether (DIEGME) may also be desirable. Refer to Section 8 for information on the proper use of additives.

Cold weather often causes conditions that require special care during airplane operations. **Even small accumulations of frost, ice, or snow must be removed, particularly from wing, tail and all control surfaces to assure satisfactory flight performance and handling.** Also, control surfaces must be free of any internal accumulations of ice or snow.

If snow or slush covers the takeoff surface, allowance must be made for takeoff distances which will be increasingly extended as the snow or slush depth increases. The depth and consistency of this cover can, in fact, prevent takeoff in many instances.



(Continued Next Page)

COLD WEATHER OPERATION (Continued)

STARTING

When air temperatures are below 20°F (-6°C), use an external preheater and an external power source whenever possible to obtain positive starting and to reduce wear and abuse to the engine and electrical system. Preheat will thaw the oil trapped in the oil cooler, which probably will be congealed prior to starting in extremely cold temperatures.

WARNING

WHEN TURNING THE PROPELLER BY HAND, TREAT IT AS IF THE MAGNETOS SWITCH IS IN THE ON POSITION. A LOOSE OR BROKEN GROUND WIRE ON EITHER MAGNETO COULD ENERGIZE THE ENGINE.

Prior to starting on cold mornings, it is advisable to turn the propeller manually through several engine compression cycles by hand to loosen the oil, so the engine cranks (motors) more easily and uses less battery power. When the propeller is turned manually, turn it in the opposite direction to normal engine rotation for greater safety. Opposite rotation disengages the magneto impulse couplings and prevents possible unwanted ignition.

When using an external power source, the MASTER switch ALT and BAT sections must be in the OFF position before connecting the external power source to the airplane receptacle. Refer to Section 7, External Power Receptacle, for external power source operations.

(Continued Next Page)

COLD WEATHER OPERATION (Continued)

STARTING (Continued)

Cold weather starting procedures are the same as the normal starting procedures. However, to conserve battery power the beacon light can be left off until the engine is started. Use caution to prevent inadvertent forward movement of the airplane during starting when parked on snow or ice.

During cold weather starting, when performing the Standby Battery energy level test, the test lamp may not illuminate and the BUS E volts may be less than 24 volts before turning on the MASTER (ALT and BAT) switch. After engine start, verify the S BATT ammeter shows a charge (positive) at 1000 RPM or greater. Prior to takeoff verify the S BATT ammeter shows a charge less than 0.4 amps.

NOTE

If the engine does not start during the first few attempts, or if engine firing diminishes in strength, the spark plugs may be frosted over. Preheat must be used before another start is attempted.

During cold weather operations, the oil temperature indicator may not be in the green band prior to takeoff if outside air temperatures are very cold. After a suitable warm up period (2 to 5 minutes at 1000 RPM), accelerate the engine several times to higher engine RPMs. If the engine accelerates smoothly and the oil pressure remains normal and steady, the airplane is ready for takeoff.

WINTERIZATION KIT

An optional winterization kit is available and may be utilized when cold weather operations are conducted. Refer to Section 9, Supplement 5 for installation and operational details.

HOT WEATHER OPERATIONS

Refer to the general warm temperature starting information under Starting Engine in this section. Avoid prolonged engine operation on the ground.

NOISE CHARACTERISTICS

The certified takeoff noise level for the Model 182T at 3100 pounds maximum weight is 77.7 dB(A) per 14 CFR 36 Appendix G (through Amendment 36-21) and 81.1 dB(A) per ICAO Annex 16 Chapter 10 (through Amendment 4). No determination has been made that the noise levels of this airplane are, or should be, acceptable or unacceptable for operation at, into, or out of, any airport.

The following procedures are suggested to minimize the effect of airplane noise on the public:

1. Pilots operating airplanes under VFR over outdoor assemblies of persons, recreational and park areas, and other noise sensitive areas should make every effort to fly not less than 2000 feet above the surface, weather permitting, even though flight at a lower level may be consistent with the provisions of government regulations.
2. During departure from or approach to an airport, climb after takeoff and descent for landing should be made so as to avoid prolonged flight at low altitude near noise sensitive areas.

NOTE

The above recommended procedures do not apply where they would conflict with Air Traffic Control clearances or instructions, or where, in the pilot's judgment, an altitude of less than 2000 feet is necessary to adequately exercise the duty to see and avoid other airplanes.

PERFORMANCE

TABLE OF CONTENTS

	Page
Introduction	5-3
Use of Performance Charts	5-3
Sample Problem	5-4
Takeoff	5-5
Cruise	5-6
Fuel Required	5-7
Landing	5-9
Demonstrated Operating Temperature	5-9
Airspeed Calibration - Normal Static Source	5-10
Airspeed Calibration - Alternate Static Source	5-11
Altimeter Correction - Alternate Static Source	5-12
Temperature Conversion Chart	5-13
Stall Speeds At 3100 Pounds	5-14
Crosswind Component	5-15
Short Field Takeoff Distance At 3100 Pounds	5-16
Short Field Takeoff Distance At 2700 Pounds	5-17
Short Field Takeoff Distance At 2300 Pounds	5-18
Maximum Rate Of Climb At 3100 Pounds	5-19
Time, Fuel And Distance To Climb - Maximum Rate of Climb	5-20
Time, Fuel And Distance To Climb - Normal Climb	5-21
Cruise Performance	5-22
Range Profile	5-33
Endurance Profile	5-35
Short Field Landing Distance At 2950 Pounds	5-37/5-38

INTRODUCTION

Performance data charts on the following pages are presented so that you may know what to expect from the airplane under various conditions and to facilitate the planning of flights in detail with reasonable accuracy. The data in the charts has been computed from actual flight tests with the airplane and engine in good condition and using average piloting techniques.

It should be noted that performance information presented in the range and endurance profile charts allows for 45 minutes reserve fuel at the specified power setting. Fuel flow data for cruise is based on the recommended lean mixture setting at all altitudes. Some indeterminate variables such as mixture leaning technique, fuel metering characteristics, engine and propeller condition, and air turbulence may account for variations of 10% or more in range and endurance. Therefore, it is important to utilize all available information to estimate the fuel required for the particular flight and to flight plan in a conservative manner.

USE OF PERFORMANCE CHARTS

Performance data is presented in tabular or graphical form to illustrate the effect of different variables. Sufficiently detailed information is provided in the tables so that conservative values can be selected and used to determine the particular performance figure with reasonable accuracy.

SAMPLE PROBLEM

The following sample flight problem utilizes information from the various charts to determine the predicted performance data for a typical flight. Assume the following information has already been determined:

AIRPLANE CONFIGURATION:

Takeoff weight	3100 Pounds
Usable fuel	87.0 Gallons

TAKEOFF CONDITIONS:

Field pressure altitude	1500 Feet
Temperature	28°C (16°C Above Standard)
Wind component along runway	12 Knot Headwind
Field length	3500 Feet

CRUISE CONDITIONS:

Total distance	450 Nautical Miles
Pressure altitude	7500 Feet
Temperature	16°C
Expected wind enroute	10 Knot Headwind

LANDING CONDITIONS:

Field pressure altitude	2000 Feet
Temperature	25°C
Field length	3000 Feet

(Continued Next Page)

SAMPLE PROBLEM (Continued)

TAKEOFF

The takeoff distance chart, Figure 5-6, should be consulted, keeping in mind that distances shown are based on the short field technique. Conservative distances can be established by reading the chart at the next higher value of weight, altitude and temperature. For example, in this particular sample problem, the takeoff distance information presented for a weight of 3100 pounds, pressure altitude of 2000 feet and a temperature of 30°C should be used and results in the following:

Ground roll	1055 Feet
Total distance to clear a 50-foot obstacle	2035 Feet

These distances are well within the available takeoff field length. However, a correction for the effect of wind may be made based on information presented in the note section of the takeoff chart. The correction for a 12 knot headwind is:

$$\frac{12 \text{ Knots}}{9 \text{ Knots}} \times 10\% = 13\% \text{ Decrease}$$

This results in the following distances, corrected for wind:

Ground roll, zero wind	1055 Feet
Decrease in ground roll (1055 feet X 13%)	<u>-137 Feet</u>
Corrected ground roll	918 Feet
Total distance to clear a 50-foot obstacle, zero wind	2035 Feet
Decrease in total distance (2035 feet X 13%)	<u>-265 Feet</u>
Corrected total distance to clear 50-foot obstacle	1770 Feet

(Continued Next Page)

SAMPLE PROBLEM (Continued)

CRUISE

The cruising altitude should be selected based on a consideration of trip length, winds aloft and the airplane's performance. A typical cruising altitude and the expected wind enroute have been given for this sample problem. However, the power setting selection for cruise must be determined based on several considerations. These include the cruise performance characteristics presented in Figure 5-9, the range profile chart presented in Figure 5-10, and the endurance profile chart presented in Figure 5-11.

The relationship between power and range is illustrated by the range profile chart. Considerable fuel savings and longer range result when lower power settings are used. For this sample problem, a cruise power of approximately 60% will be used.

The cruise performance chart, Figure 5-9, is entered at 8000 feet pressure altitude and 20°C above standard temperature. These values most nearly correspond to the planned altitude and expected temperature conditions. The engine speed chosen is 2400 RPM and 19 inches of manifold pressure, which results in the following:

Power	60%
True airspeed	130 Knots
Cruise fuel flow	10.7 GPH

(Continued Next Page)

SAMPLE PROBLEM (Continued)

FUEL REQUIRED

The total fuel requirement for the flight may be estimated using the performance information in Figure 5-8 and Figure 5-9. For this sample problem, the time, fuel and distance to climb may be determined from Figure 5-8 for normal climb. The difference between the values shown in the table for 2000 feet and 8000 feet results in the following:

Time: 11 Minutes
Fuel: 2.7 Gallons
Distance: 18 Nautical Miles

These values are for a standard temperature and are sufficiently accurate for most flight planning purposes. However, a further correction for the effect of temperature may be made as noted on the climb chart. The approximate effect of a nonstandard temperature is to increase the time, fuel and distance by 10% for each 10°C above standard temperature, due to the lower rate of climb. In this case, assuming a temperature 16°C above standard the correction would be:

$$\frac{16^{\circ}\text{C}}{10^{\circ}\text{C}} \times 10\% = 16\% \text{ Increase}$$

With this factor included, the fuel estimate would be calculated as follows:

Fuel to climb, standard temperature	2.7 Gallons
Increase due to non-standard temperature (2.7 X 16%)	<u>0.5 Gallons</u>
Corrected fuel to climb	3.2 Gallons

Using a similar procedure for the distance to climb results in 21 nautical miles.

The resultant cruise distance is:

Total distance	450 Nautical Miles
Climb distance	<u>-21 Nautical Miles</u>
Cruise distance	429 Nautical Miles

(Continued Next Page)

SAMPLE PROBLEM (Continued)

FUEL REQUIRED (Continued)

With an expected 10 knot headwind, the ground speed for cruise is predicted to be:

$$\begin{array}{r} 130 \text{ Knots} \\ -10 \text{ Knots} \\ \hline 120 \text{ Knots} \end{array}$$

Therefore, the time required for the cruise portion of the trip is:

$$\frac{429 \text{ Nautical Miles}}{120 \text{ Knots}} = 3.6 \text{ Hours}$$

The fuel required for cruise is:

$$3.6 \text{ hours} \times 10.7 \text{ gallons/hour} = 38.5 \text{ Gallons}$$

A 45-minute reserve requires:

$$\frac{45}{60} \times 10.7 \text{ gallons/hour} = 8.0 \text{ Gallons}$$

The total estimated fuel required is as follows:

Engine start, taxi, and takeoff	1.7 Gallons
Climb	3.2 Gallons
Cruise	38.5 Gallons
Reserve	<u>8.0</u> Gallons
Total fuel required	51.4 Gallons

Once the flight is underway, ground speed checks will provide a more accurate basis for estimating the time enroute and the corresponding fuel required to complete the trip with ample reserve.

(Continued Next Page)

SAMPLE PROBLEM (Continued)

LANDING

A procedure similar to takeoff should be used for estimating the landing distance at the destination airport. Figure 5-12 presents landing distance information for the short field technique. The distances corresponding to 2000 feet and 30°C are as follows:

- Ground roll 670 Feet
- Total distance to clear a 50-foot obstacle 1480 Feet

A correction for the effect of wind may be made based on information presented in the note section of the landing chart, using the same procedure as outlined for takeoff.

DEMONSTRATED OPERATING TEMPERATURE

Satisfactory engine cooling has been demonstrated for this airplane with an outside air temperature 23°C above standard. This is not to be considered as an operating limitation. Reference should be made to Section 2 for engine operating limitations.

AIRSPEED CALIBRATION

NORMAL STATIC SOURCE

CONDITIONS:

Power required for level flight or maximum power descent.

Flaps UP													
KIAS	55	60	70	80	90	100	110	120	130	140	150	160	
KCAS	61	65	73	82	90	99	108	117	126	136	146	156	
Flaps 20°													
KIAS	45	50	60	70	80	90	100	110	120	---	---	---	
KCAS	52	57	64	72	80	88	98	108	118	---	---	---	
Flaps FULL													
KIAS	40	50	60	70	80	90	95	---	---	---	---	---	
KCAS	51	56	63	71	80	89	94	---	---	---	---	---	

Figure 5-1 (Sheet 1 of 2)

AIRSPEED CALIBRATION ALTERNATE STATIC SOURCE

CONDITIONS:

Power required for level flight or maximum power descent.

Flaps UP													
KIAS	55	60	70	80	90	100	110	120	130	140	150	160	
ALT													
KIAS	53	58	70	81	91	101	111	121	131	141	151	161	
Flaps 20°													
KIAS	40	50	60	70	80	90	100	110	120	---	---	---	
ALT													
KIAS	42	52	60	70	79	89	99	110	120	---	---	---	
Flaps FULL													
KIAS	40	50	60	70	80	90	95	---	---	---	---	---	
ALT													
KIAS	35	45	55	66	77	87	93	---	---	---	---	---	

NOTE

Windows and ventilators closed, cabin heater, cabin air,
 and defroster on maximum.

Figure 5-1 (Sheet 2)

ALTIMETER CORRECTION

ALTERNATE STATIC SOURCE

CONDITIONS:

Power required for level flight or maximum power descent cruise configuration. Altimeter corrections for the takeoff configuration are less than 50 feet.

CONDITION Flaps UP	CORRECTION TO BE ADDED - FEET					
	KIAS - Alternate Static Source ON					
	60	80	100	120	140	160
Sea Level	30	10	-20	-30	-50	-50
2000 Feet	30	10	-20	-30	-50	-60
4000 Feet	30	10	-20	-40	-50	-60
6000 Feet	40	20	-20	-40	-60	-70
8000 Feet	40	20	-20	-40	-60	-70
10,000 Feet	50	20	-20	-50	-70	-70
12,000 Feet	50	20	-20	-50	-70	-70
14,000 Feet	50	20	-20	-50	-70	-80

CONDITION Flaps FULL	CORRECTION TO BE ADDED - FEET					
	KIAS - Alternate Static Source ON					
	60	80	100	120	140	160
Sea Level	40	20	10	---	---	---
2000 Feet	40	20	10	---	---	---
4000 Feet	40	20	10	---	---	---
6000 Feet	40	20	10	---	---	---
8000 Feet	40	20	10	---	---	---
10,000 Feet	50	20	10	---	---	---

NOTE

Add correction to desired altitude to obtain indicated altitude to fly. Windows and ventilators closed, cabin heater, cabin air, and defroster on maximum.

Figure 5-2

TEMPERATURE CONVERSION CHART

B3093

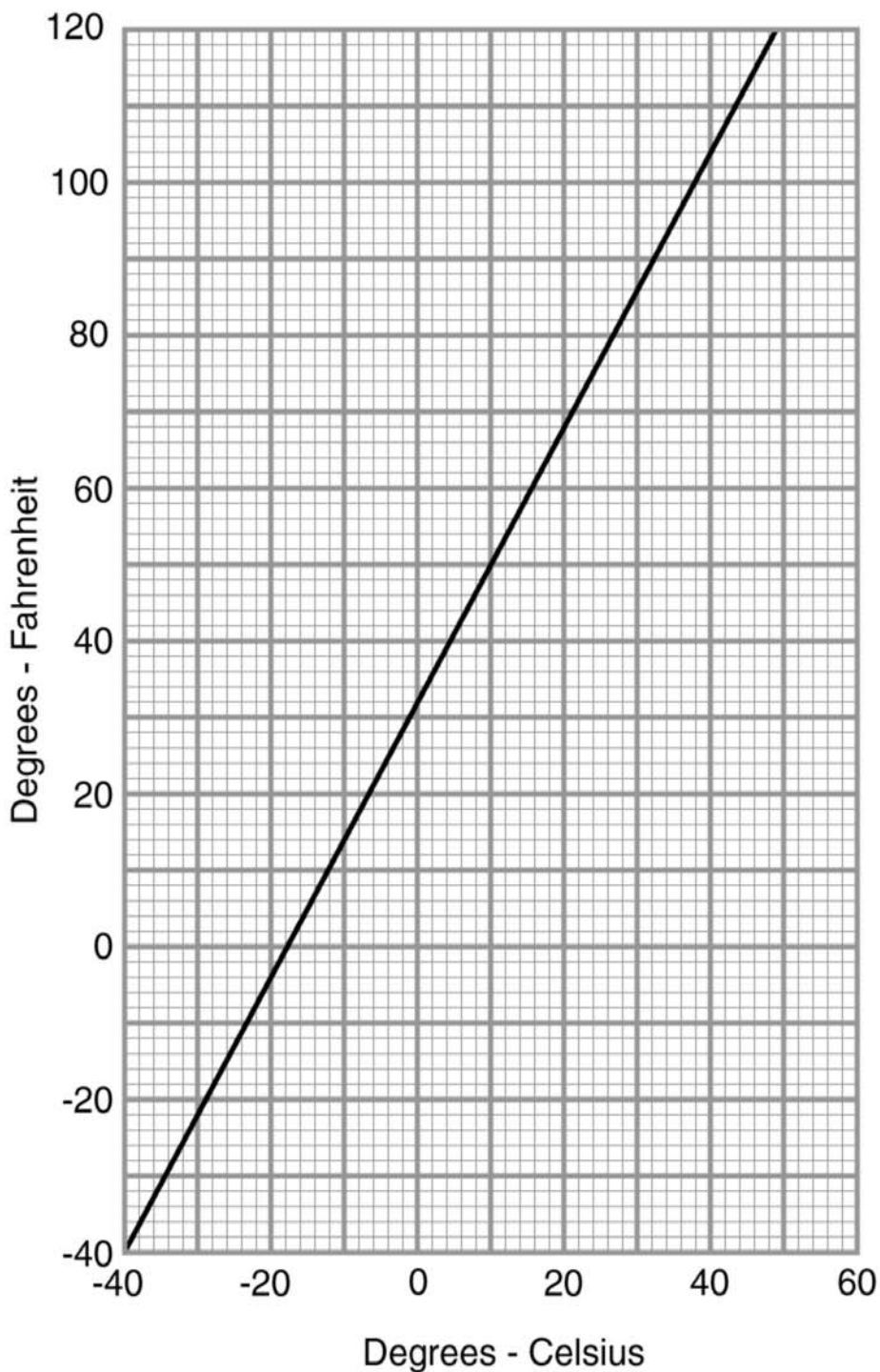

Figure 5-3

STALL SPEED AT 3100 POUNDS

CONDITIONS:
Power IDLE

MOST REARWARD CENTER OF GRAVITY

FLAP SETTING	ANGLE OF BANK							
	0°		30°		45°		60°	
	KIAS	KCAS	KIAS	KCAS	KIAS	KCAS	KIAS	KCAS
UP	50	54	54	58	59	64	71	76
20°	43	50	46	54	51	59	61	71
FULL	40	49	43	53	48	58	57	69

MOST FORWARD CENTER OF GRAVITY

FLAP SETTING	ANGLE OF BANK							
	0°		30°		45°		60°	
	KIAS	KCAS	KIAS	KCAS	KIAS	KCAS	KIAS	KCAS
UP	51	56	55	60	61	67	72	79
20°	44	52	47	56	52	62	62	74
FULL	41	50	44	54	49	59	58	71

NOTE

- Altitude loss during a stall recovery may be as much as 250 feet.
- KIAS values are approximate.

Figure 5-4

CROSSWIND COMPONENT

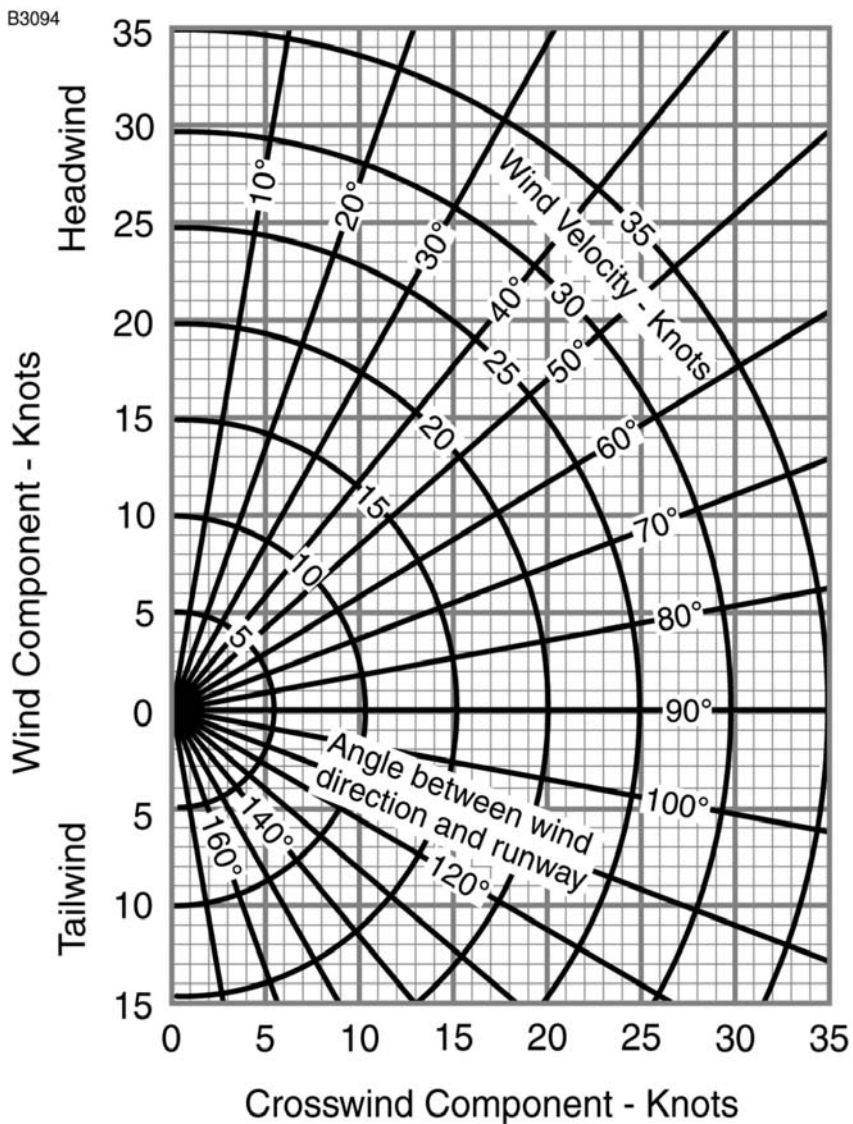

NOTE

Maximum demonstrated crosswind velocity is 15 knots (not a limitation).

Figure 5-5

SHORT FIELD TAKEOFF DISTANCE AT 3100 POUNDS

CONDITIONS:

Flaps 20°

2400 RPM, Full Throttle and mixture set prior to brake release.

Cowl Flaps OPEN

Paved, Level, Dry Runway

Lift Off: 49 KIAS

Zero Wind

Speed at 50 Feet: 58 KIAS

Pressure Altitude - Feet	0°C		10°C		20°C		30°C		40°C	
	Gnd Roll Feet	Total Feet To Clear 50 Foot Obst	Gnd Roll Feet	Total Feet To Clear 50 Foot Obst	Gnd Roll Feet	Total Feet To Clear 50 Foot Obst	Gnd Roll Feet	Total Feet To Clear 50 Foot Obst	Gnd Roll Feet	Total Feet To Clear 50 Foot Obst
Sea Level	715	1365	765	1460	825	1570	885	1680	945	1800
1000	775	1490	835	1600	900	1720	965	1845	1030	1980
2000	850	1635	915	1760	980	1890	1055	2035	1130	2190
3000	925	1800	995	1940	1070	2090	1150	2255	1235	2435
4000	1015	1990	1090	2150	1175	2325	1260	2515	1355	2720
5000	1110	2210	1195	2395	1290	2595	1385	2820	1485	3070
6000	1220	2470	1315	2690	1415	2930	1520	3200	1635	3510
7000	1340	2785	1445	3045	1560	3345	1675	3685	---	---
8000	1480	3175	1595	3500	1720	3880	---	---	---	---

NOTE

- Short field technique as specified in Section 4.
- Prior to takeoff, the mixture should be leaned to the Maximum Power Fuel Flow schedule in a full throttle, static run-up.
- Decrease distances 10% for each 9 knots headwind. For operation with tail winds up to 10 knots, increase distances by 10% for each 2 knots.
- Where distance value have been deleted, climb performance after lift-off is less than 150 FPM at takeoff speed.
- For operation on dry, grass runway, increase distances by 15% of the "ground roll" figure.

Figure 5-6 (Sheet 1 of 3)

SHORT FIELD TAKEOFF DISTANCE AT 2700 POUNDS

CONDITIONS:

Flaps 20°

2400 RPM, Full Throttle and mixture set prior to brake release.

Cowl Flaps OPEN

Paved, Level, Dry Runway

Zero Wind

Lift Off: 45 KIAS

Speed at 50 Feet: 54 KIAS

Pressure Altitude - Feet	0°C		10°C		20°C		30°C		40°C	
	Gnd Roll Feet	Total Feet To Clear 50 Foot Obst	Gnd Roll Feet	Total Feet To Clear 50 Foot Obst	Gnd Roll Feet	Total Feet To Clear 50 Foot Obst	Gnd Roll Feet	Total Feet To Clear 50 Foot Obst	Gnd Roll Feet	Total Feet To Clear 50 Foot Obst
Sea Level	520	995	560	1065	600	1135	645	1215	690	1295
1000	565	1080	610	1155	655	1235	700	1320	750	1410
2000	615	1180	665	1260	710	1350	765	1445	820	1545
3000	675	1285	725	1380	775	1480	835	1585	895	1695
4000	735	1410	790	1510	850	1625	910	1740	975	1870
5000	805	1550	865	1665	930	1790	1000	1920	1070	2065
6000	880	1705	950	1840	1020	1980	1095	2135	1175	2300
7000	965	1890	1040	2040	1120	2205	1200	2380	1290	2575
8000	1060	2100	1145	2275	1230	2465	1320	2675	1420	2910

NOTE

- Short field technique as specified in Section 4.
- Prior to takeoff, the mixture should be leaned to the Maximum Power Fuel Flow schedule in a full throttle, static run-up.
- Decrease distances 10% for each 9 knots headwind. For operation with tail winds up to 10 knots, increase distances by 10% for each 2 knots.
- For operation on dry, grass runway, increase distances by 15% of the "ground roll" figure.

Figure 5-6 (Sheet 2)

SHORT FIELD TAKEOFF DISTANCE AT 2300 POUNDS

CONDITIONS:

Flaps 20°

2400 RPM, Full Throttle and mixture set prior to brake release.

Cowl Flaps OPEN

Paved, Level, Dry Runway

Lift Off: 42 KIAS

Zero Wind

Speed at 50 Feet: 50 KIAS

Pressure Altitude - Feet	0°C		10°C		20°C		30°C		40°C	
	Gnd Roll Feet	Total Feet To Clear 50 Foot Obst	Gnd Roll Feet	Total Feet To Clear 50 Foot Obst	Gnd Roll Feet	Total Feet To Clear 50 Foot Obst	Gnd Roll Feet	Total Feet To Clear 50 Foot Obst	Gnd Roll Feet	Total Feet To Clear 50 Foot Obst
Sea Level	365	705	390	750	420	800	450	850	480	905
1000	395	765	425	815	455	870	490	925	520	985
2000	430	830	460	885	495	940	530	1005	565	1070
3000	470	900	505	960	540	1025	580	1090	620	1165
4000	510	980	550	1045	590	1115	630	1190	675	1270
5000	555	1065	600	1140	640	1220	690	1305	735	1390
6000	610	1165	655	1250	700	1335	755	1430	805	1530
7000	665	1275	715	1370	770	1470	825	1570	885	1685
8000	730	1405	785	1510	845	1620	905	1735	970	1865

NOTE

- Short field technique as specified in Section 4.
- Prior to takeoff, the mixture should be leaned to the Maximum Power Fuel Flow schedule in a full throttle, static run-up.
- Decrease distances 10% for each 9 knots headwind. For operation with tail winds up to 10 knots, increase distances by 10% for each 2 knots.
- For operation on dry, grass runway, increase distances by 15% of the "ground roll" figure.

Figure 5-6 (Sheet 3)

MAXIMUM RATE OF CLIMB AT 3100 POUNDS

CONDITIONS:

Flaps UP

2400 RPM, Full Throttle and mixture set to Maximum Power Fuel Flow Placard.

Cowl Flaps OPEN

Pressure Altitude - Feet	Climb Speed - KIAS	Rate of Climb - FPM			
		-20°C	0°C	20°C	40°C
Sea Level	80	1055	980	905	835
2000	79	945	875	805	735
4000	78	840	770	705	635
6000	77	735	670	605	535
8000	75	625	560	495	430
10,000	74	520	455	390	330
12,000	73	410	350	285	225
14,000	72	310	250	190	130

Figure 5-7

**TIME, FUEL AND DISTANCE TO CLIMB
AT 3100 POUNDS**

MAXIMUM RATE OF CLIMB

CONDITIONS:

Flaps UP
2400 RPM, Full Throttle and mixture set to Maximum Power Fuel Flow
Placard.
Cowl Flaps OPEN
Standard Temperature

Pressure Altitude Feet	Climb Speed KIAS	Rate of Climb FPM	From Sea Level		
			Time Minutes	Fuel Used Gallons	Distance NM
Sea Level	80	925	0	0.0	0
2000	79	835	2	0.8	3
4000	78	750	5	1.5	7
6000	77	660	8	2.3	11
8000	75	565	11	3.2	16
10,000	74	470	15	4.2	21
12,000	73	375	20	5.2	29
14,000	72	285	26	6.5	38

NOTE

- Add 1.7 gallons of fuel for engine start, taxi and takeoff allowance.
- Increase time, fuel and distance by 10% for each 10°C above standard temperature.
- Distances shown are based on zero wind.

Figure 5-8 (Sheet 1 of 2)

TIME, FUEL AND DISTANCE TO CLIMB AT 3100 POUNDS

NORMAL CLIMB - 90 KIAS

CONDITIONS:

Flaps UP
 2400 RPM, Full Throttle and mixture set to Maximum Power Fuel Flow
 Placard.
 Cowl Flaps OPEN
 Standard Temperature

Pressure Altitude Feet	Climb Speed KIAS	Rate of Climb FPM	From Sea Level		
			Time Minutes	Fuel Used Gallons	Distance NM
Sea Level	90	665	0	0.0	0
2000	90	625	3	0.8	5
4000	90	580	6	1.6	10
6000	90	540	10	2.5	16
8000	90	455	14	3.5	23
10,000	90	370	19	4.6	31

NOTE

- Add 1.7 gallons of fuel for engine start, taxi and takeoff allowance.
- Increase time, fuel and distance by 10% for each 10°C above standard temperature.
- Distances shown are based on zero wind.

Figure 5-8 (Sheet 2)

CRUISE PERFORMANCE
PRESSURE ALTITUDE SEA LEVEL

CONDITIONS:

3100 Pounds

Recommended Lean Mixture

Cowl Flaps CLOSED

RPM	MP	20°C BELOW STANDARD TEMP -5°C			STANDARD TEMPERATURE 15°C			20°C ABOVE STANDARD TEMP 35°C		
		% MCP	KTAS	GPH	% MCP	KTAS	GPH	% MCP	KTAS	GPH
2400	27	---	---	---	---	---	---	---	---	---
	26	---	---	---	---	---	---	82	140	14.3
	25	84	134	14.5	81	136	14.0	78	138	13.5
	24	79	132	13.6	76	133	13.2	74	135	12.8
	23	74	129	12.8	71	130	12.4	69	131	12.1
	22	69	126	12.1	67	127	11.7	65	127	11.4
	21	65	122	11.4	62	122	11.1	60	123	10.8
	20	60	118	10.7	58	118	10.4	56	118	10.2
2300	27	---	---	---	---	---	---	84	141	14.5
	26	---	---	---	82	137	14.2	79	139	13.7
	25	80	133	13.9	78	135	13.4	75	136	13.0
	24	76	130	13.2	73	132	12.7	71	132	12.3
	23	71	127	12.4	69	128	12.0	67	129	11.7
	22	67	124	11.7	65	124	11.4	62	125	11.1
	21	62	120	11.1	60	120	10.8	58	121	10.5
	20	58	116	10.4	56	116	10.2	54	116	9.9
2200	27	---	---	---	83	137	14.4	80	139	13.9
	26	82	133	14.2	79	135	13.6	76	136	13.2
	25	77	131	13.4	75	133	12.9	72	134	12.6
	24	73	129	12.7	71	130	12.3	68	130	11.9
	23	69	126	12.0	66	126	11.7	64	126	11.3
	22	65	122	11.4	62	122	11.1	60	123	10.8
	21	60	118	10.8	58	119	10.5	56	118	10.2
	20	56	114	10.2	54	114	9.9	52	114	9.7

NOTE

- Maximum cruise power is 80% MCP. Power settings above 80% are listed to aid interpolation.
- For best economy, operate at peak EGT.

Figure 5-9 (Sheet 1 of 11)

CRUISE PERFORMANCE
PRESSURE ALTITUDE SEA LEVEL

CONDITIONS:
 3100 Pounds
 Recommended Lean Mixture
 Cowl Flaps CLOSED

RPM	MP	20°C BELOW STANDARD TEMP -5°C			STANDARD TEMPERATURE 15°C			20°C ABOVE STANDARD TEMP 35°C		
		% MCP	KTAS	GPH	% MCP	KTAS	GPH	% MCP	KTAS	GPH
2100	27	82	133	14.2	79	135	13.7	76	136	13.2
	26	78	131	13.4	75	133	13.0	73	134	12.6
	25	74	129	12.8	71	130	12.4	69	130	12.0
	24	70	126	12.1	67	127	11.8	65	127	11.4
	23	66	123	11.5	63	123	11.2	61	123	10.9
	22	61	119	10.9	59	120	10.6	57	120	10.4
	21	57	115	10.4	55	116	10.1	54	115	9.9
	20	53	111	9.8	51	111	9.6	50	111	9.3
2000	27	78	131	13.4	75	133	13.0	72	134	12.6
	26	74	129	12.8	71	130	12.4	69	131	12.0
	25	70	126	12.2	67	127	11.8	65	127	11.5
	24	66	123	11.6	64	124	11.3	62	124	11.0
	23	62	120	11.0	60	120	10.7	58	121	10.5
	22	58	116	10.5	56	117	10.2	54	116	10.0
	21	54	113	10.0	53	112	9.7	51	112	9.5
	20	51	108	9.4	49	108	9.2	47	108	9.0

NOTE

- Maximum cruise power is 80% MCP. Power settings above 80% are listed to aid interpolation.
- For best economy, operate at peak EGT.

Figure 5-9 (Sheet 2)

CRUISE PERFORMANCE
PRESSURE ALTITUDE 2000 FEET

CONDITIONS:

3100 Pounds

Recommended Lean Mixture

Cowl Flaps CLOSED

RPM	MP	20°C BELOW			STANDARD			20°C ABOVE		
		STANDARD TEMP -9°C			TEMPERATURE 11°C			STANDARD TEMP 31°C		
		% MCP	KTAS	GPH	% MCP	KTAS	GPH	% MCP	KTAS	GPH
2400	26	---	---	---	---	---	---	---	---	---
	25	---	---	---	83	140	14.4	80	142	13.9
	24	81	136	14.1	79	138	13.6	76	139	13.2
	23	77	133	13.3	74	134	12.8	71	135	12.4
	22	72	130	12.5	69	131	12.1	67	131	11.7
	21	67	126	11.8	65	126	11.4	63	127	11.1
	20	62	122	11.0	60	122	10.7	58	122	10.5
2300	26	---	---	---	---	---	---	82	143	14.2
	25	83	137	14.4	80	139	13.9	77	140	13.4
	24	78	134	13.6	76	136	13.1	73	137	12.7
	23	74	131	12.8	71	133	12.4	69	133	12.0
	22	69	128	12.1	67	128	11.7	65	129	11.4
	21	65	124	11.4	62	124	11.1	60	125	10.8
	20	60	120	10.7	58	120	10.5	56	120	10.2
2200	26	---	---	---	81	139	14.1	78	140	13.6
	25	80	135	13.8	77	137	13.3	74	138	12.9
	24	75	132	13.1	73	134	12.6	70	134	12.3
	23	71	129	12.4	69	130	12.0	66	130	11.6
	22	67	126	11.7	64	126	11.4	62	127	11.0
	21	62	122	11.1	60	122	10.8	58	122	10.5
	20	58	118	10.5	56	118	10.2	54	118	9.9

NOTE

- Maximum cruise power is 80% MCP. Power settings above 80% are listed to aid interpolation.
- For best economy, operate at peak EGT.

Figure 5-9 (Sheet 3)

CRUISE PERFORMANCE
PRESSURE ALTITUDE 2000 FEET

CONDITIONS:
 3100 Pounds
 Recommended Lean Mixture
 Cowl Flaps CLOSED

RPM	MP	20°C BELOW			STANDARD			20°C ABOVE		
		STANDARD TEMP -9°C			TEMPERATURE 11°C			STANDARD TEMP 31°C		
		% MCP	KTAS	GPH	% MCP	KTAS	GPH	% MCP	KTAS	GPH
2100	26	80	135	13.9	77	137	13.4	75	138	12.9
	25	76	133	13.1	73	134	12.7	71	134	12.3
	24	72	130	12.5	69	131	12.1	67	131	11.7
	23	68	127	11.8	65	127	11.5	63	127	11.2
	22	64	123	11.2	61	123	10.9	59	124	10.6
	21	59	119	10.6	57	119	10.4	55	119	10.1
	20	55	115	10.1	53	115	9.8	52	115	9.6
2000	26	76	133	13.1	73	134	12.7	71	134	12.3
	25	72	130	12.5	69	131	12.1	67	131	11.8
	24	68	127	11.9	66	127	11.5	64	128	11.2
	23	64	124	11.3	62	124	11.0	60	124	10.7
	22	60	120	10.8	58	120	10.5	56	120	10.2
	21	56	116	10.2	54	116	10.0	53	116	9.7
	20	52	112	9.7	51	112	9.4	49	111	9.2

NOTE

- Maximum cruise power is 80% MCP. Power settings above 80% are listed to aid interpolation.
- For best economy, operate at peak EGT.

Figure 5-9 (Sheet 4)

CRUISE PERFORMANCE
PRESSURE ALTITUDE 4000 FEET

CONDITIONS:

3100 Pounds

Recommended Lean Mixture

Cowl Flaps CLOSED

RPM	MP	20°C BELOW			STANDARD			20°C ABOVE		
		STANDARD TEMP -13°C			TEMPERATURE 7°C			STANDARD TEMP 27°C		
		% MCP	KTAS	GPH	% MCP	KTAS	GPH	% MCP	KTAS	GPH
2400	25	---	---	---	---	---	---	83	146	14.4
	24	84	140	14.6	81	142	14.0	78	143	13.6
	23	79	138	13.7	76	139	13.2	74	139	12.8
	22	74	134	12.9	72	135	12.5	69	135	12.1
	21	70	130	12.1	67	131	11.7	65	131	11.4
	20	65	126	11.4	62	126	11.1	60	126	10.8
2300	25	---	---	---	83	143	14.3	80	144	13.8
	24	81	138	14.0	78	140	13.5	75	141	13.1
	23	76	135	13.2	74	137	12.8	71	137	12.4
	22	72	132	12.5	69	133	12.1	67	133	11.7
	21	67	128	11.7	65	128	11.4	62	129	11.1
	20	62	124	11.1	60	124	10.7	58	124	10.5
2200	25	82	139	14.2	79	141	13.7	77	142	13.2
	24	78	136	13.4	75	138	13.0	72	138	12.6
	23	73	133	12.7	71	134	12.3	68	134	11.9
	22	69	130	12.0	66	130	11.7	64	130	11.3
	21	65	126	11.4	62	126	11.0	60	126	10.7
	20	60	122	10.7	58	122	10.4	56	121	10.2

NOTE

- Maximum cruise power is 80% MCP. Power settings above 80% are listed to aid interpolation.
- For best economy, operate at peak EGT.

Figure 5-9 (Sheet 5)

CRUISE PERFORMANCE
PRESSURE ALTITUDE 4000 FEET

CONDITIONS:
 3100 Pounds
 Recommended Lean Mixture
 Cowl Flaps CLOSED

RPM	MP	20°C BELOW STANDARD TEMP -13°C			STANDARD TEMPERATURE 7°C			20°C ABOVE STANDARD TEMP 27°C		
		%	KTAS	GPH	%	KTAS	GPH	%	KTAS	GPH
		MCP			MCP			MCP		
2100	25	78	137	13.5	75	138	13.0	73	138	12.6
	24	74	134	12.8	71	135	12.4	69	135	12.0
	23	70	131	12.2	67	131	11.8	65	131	11.4
	22	66	127	11.5	63	127	11.2	61	127	10.9
	21	61	123	10.9	59	123	10.6	57	123	10.3
	20	57	119	10.3	55	119	10.1	53	118	9.8
2000	25	74	134	12.8	71	135	12.4	69	135	12.1
	24	70	131	12.2	68	131	11.8	65	132	11.5
	23	66	127	11.6	64	128	11.3	62	128	11.0
	22	62	124	11.0	60	124	10.7	58	124	10.4
	21	58	120	10.5	56	120	10.2	54	120	9.9
	20	54	116	9.9	52	115	9.7	51	115	9.4

NOTE

- Maximum cruise power is 80% MCP. Power settings above 80% are listed to aid interpolation.
- For best economy, operate at peak EGT.

Figure 5-9 (Sheet 6)

CRUISE PERFORMANCE
PRESSURE ALTITUDE 6000 FEET

CONDITIONS:

3100 Pounds

Recommended Lean Mixture

Cowl Flaps CLOSED

RPM	MP	20°C BELOW STANDARD TEMP -17°C			STANDARD TEMPERATURE 3°C			20°C ABOVE STANDARD TEMP 23°C		
		%	KTAS	GPH	%	KTAS	GPH	%	KTAS	GPH
		MCP			MCP			MCP		
2400	23	82	142	14.2	79	143	13.6	76	144	13.2
	22	77	138	13.3	74	139	12.8	72	139	12.4
	21	72	135	12.5	69	135	12.1	67	135	11.7
	20	67	130	11.7	65	130	11.4	62	131	11.1
	19	62	126	11.0	60	126	10.7	58	125	10.4
2300	23	79	140	13.6	76	141	13.1	73	141	12.7
	22	74	136	12.8	71	137	12.4	69	137	12.0
	21	69	132	12.1	67	133	11.7	64	133	11.4
	20	65	128	11.4	62	128	11.0	60	128	10.7
	19	60	124	10.7	58	123	10.4	56	123	10.1
2200	23	76	137	13.1	73	138	12.6	70	138	12.3
	22	71	134	12.4	69	134	12.0	66	135	11.6
	21	67	130	11.7	64	130	11.3	62	130	11.0
	20	62	126	11.0	60	126	10.7	58	125	10.4
	19	58	121	10.4	56	121	10.1	54	120	9.9
2100	23	72	135	12.5	69	135	12.1	67	135	11.7
	22	68	131	11.8	65	131	11.5	63	131	11.1
	21	63	127	11.2	61	127	10.9	59	127	10.6
	20	59	123	10.6	57	122	10.3	55	122	10.0
	19	55	118	10.0	53	118	9.8	51	117	9.5
2000	23	68	131	11.9	66	132	11.5	63	132	11.2
	22	64	127	11.3	62	128	11.0	60	128	10.7
	21	60	124	10.7	58	123	10.4	56	123	10.2
	20	56	119	10.2	54	119	9.9	52	118	9.7
	19	52	115	9.6	50	114	9.4	48	113	9.1

NOTE

- Maximum cruise power is 80% MCP. Power settings above 80% are listed to aid interpolation.
- For best economy, operate at peak EGT.

Figure 5-9 (Sheet 7)

CRUISE PERFORMANCE
PRESSURE ALTITUDE 8000 FEET

CONDITIONS:
 3100 Pounds
 Recommended Lean Mixture
 Cowl Flaps CLOSED

RPM	MP	20°C BELOW STANDARD TEMP -21°C			STANDARD TEMPERATURE -1°C			20°C ABOVE STANDARD TEMP 19°C		
		% MCP	KTAS	GPH	% MCP	KTAS	GPH	% MCP	KTAS	GPH
2400	21	74	139	12.9	72	139	12.5	69	140	12.1
	20	69	134	12.1	67	135	11.7	65	135	11.4
	19	64	130	11.4	62	130	11.0	60	130	10.7
	18	59	125	10.6	57	124	10.3	55	124	10.1
2300	21	72	136	12.5	69	137	12.0	67	137	11.7
	20	67	132	11.7	64	132	11.3	62	132	11.0
	19	62	128	11.0	60	127	10.7	58	127	10.4
	18	57	122	10.3	55	122	10.1	53	121	9.8
2200	21	69	134	12.0	66	134	11.6	64	134	11.3
	20	64	130	11.3	62	130	11.0	60	129	10.7
	19	60	125	10.7	57	125	10.4	55	124	10.1
	18	55	120	10.1	53	119	9.8	51	119	9.5
2100	21	65	131	11.5	63	131	11.2	61	131	10.8
	20	61	127	10.9	59	126	10.6	57	126	10.3
	19	57	122	10.3	55	121	10.0	53	121	9.7
	18	52	117	9.7	50	116	9.4	49	115	9.2
2000	21	62	128	11.0	60	127	10.7	58	127	10.4
	20	58	123	10.4	56	123	10.1	54	122	9.9
	19	54	118	9.9	52	118	9.6	50	117	9.4

NOTE

- Maximum cruise power is 80% MCP. Power settings above 80% are listed to aid interpolation.
- For best economy, operate at peak EGT.

Figure 5-9 (Sheet 8)

CRUISE PERFORMANCE
PRESSURE ALTITUDE 10,000 FEET

CONDITIONS:
3100 Pounds
Recommended Lean Mixture
Cowl Flaps CLOSED

RPM	MP	20°C BELOW STANDARD TEMP -25°C			STANDARD TEMPERATURE -5°C			20°C ABOVE STANDARD TEMP 15°C		
		%	KTAS	GPH	%	KTAS	GPH	%	KTAS	GPH
		MCP			MCP			MCP		
2400	20	72	139	12.5	69	139	12.1	67	139	11.7
	19	67	134	11.7	64	134	11.3	62	134	11.0
	18	62	129	11.0	59	129	10.6	57	128	10.3
2300	21	74	141	12.8	71	141	12.4	69	142	12.0
	20	69	136	12.1	66	137	11.7	64	136	11.3
	19	64	132	11.3	62	132	11.0	60	131	10.7
	18	59	126	10.6	57	126	10.3	55	125	10.1
2200	20	66	134	11.6	64	134	11.3	62	133	10.9
	19	62	129	11.0	59	129	10.6	57	128	10.4
	18	57	124	10.3	55	123	10.0	53	123	9.8
2100	20	63	131	11.2	61	130	10.8	59	130	10.5
	19	59	126	10.5	56	125	10.2	54	125	10.0
	18	54	121	9.9	52	120	9.7	50	119	9.4
2000	20	60	127	10.7	58	127	10.4	55	126	10.1
	19	56	122	10.1	54	122	9.8	52	121	9.6
	18	51	117	9.6	50	116	9.3	48	115	9.0

NOTE

- Maximum cruise power is 80% MCP. Power settings above 80% are listed to aid interpolation.
- For best economy, operate at peak EGT.

Figure 5-9 (Sheet 9)

CRUISE PERFORMANCE
PRESSURE ALTITUDE 12,000 FEET

CONDITIONS:
 3100 Pounds
 Recommended Lean Mixture
 Cowl Flaps CLOSED

RPM	MP	20°C BELOW STANDARD TEMP -29°C			STANDARD TEMPERATURE -9°C			20°C ABOVE STANDARD TEMP 11°C		
		%	KTAS	GPH	%	KTAS	GPH	%	KTAS	GPH
		MCP			MCP			MCP		
2400	18	64	133	11.3	61	133	10.9	59	133	10.6
	17	59	127	10.5	56	127	10.2	54	126	10.0
	16	53	121	9.8	51	120	9.6	50	119	9.3
2300	18	61	131	10.9	59	130	10.6	57	130	10.3
	17	56	125	10.2	54	124	10.0	52	123	9.7
	16	52	118	9.6	50	118	9.3	48	117	9.0
2200	18	59	128	10.6	57	128	10.3	55	127	10.0
	17	54	122	9.9	52	121	9.7	50	121	9.4
2100	18	56	125	10.2	54	124	9.9	52	123	9.6
	17	52	119	9.6	50	118	9.3	48	117	9.1
2000	19	57	126	10.4	55	125	10.1	53	125	9.8
	18	53	121	9.8	51	120	9.5	49	119	9.3

NOTE

- Maximum cruise power is 80% MCP. Power settings above 80% are listed to aid interpolation.
- For best economy, operate at peak EGT.

Figure 5-9 (Sheet 10)

CRUISE PERFORMANCE
PRESSURE ALTITUDE 14,000 FEET

CONDITIONS:
3100 Pounds
Recommended Lean Mixture
Cowl Flaps CLOSED

RPM	MP	20°C BELOW STANDARD TEMP -33°C			STANDARD TEMPERATURE -13°C			20°C ABOVE STANDARD TEMP 7°C		
		% MCP	KTAS	GPH	% MCP	KTAS	GPH	% MCP	KTAS	GPH
		2400	16	56	126	10.1	53	125	9.8	51
	15	50	118	9.4	48	117	9.1	47	116	8.9
2300	16	53	123	9.8	51	122	9.6	50	121	9.3
2200	16	51	120	9.6	49	119	9.3	48	118	9.0
2100	16	49	116	9.2	47	115	8.9	45	114	8.7

NOTE

- Maximum cruise power is 80% MCP. Power settings above 80% are listed to aid interpolation.
- For best economy, operate at peak EGT.

Figure 5-9 (Sheet 11)

RANGE PROFILE
45 MINUTES RESERVE
64 GALLONS USABLE FUEL

CONDITIONS:
 3100 Pounds
 Normal Climb to 10,000 feet then, Maximum Performance Climb, with Placard
 Mixture
 Recommended Lean Mixture for Cruise
 Standard Temperature
 Zero Wind

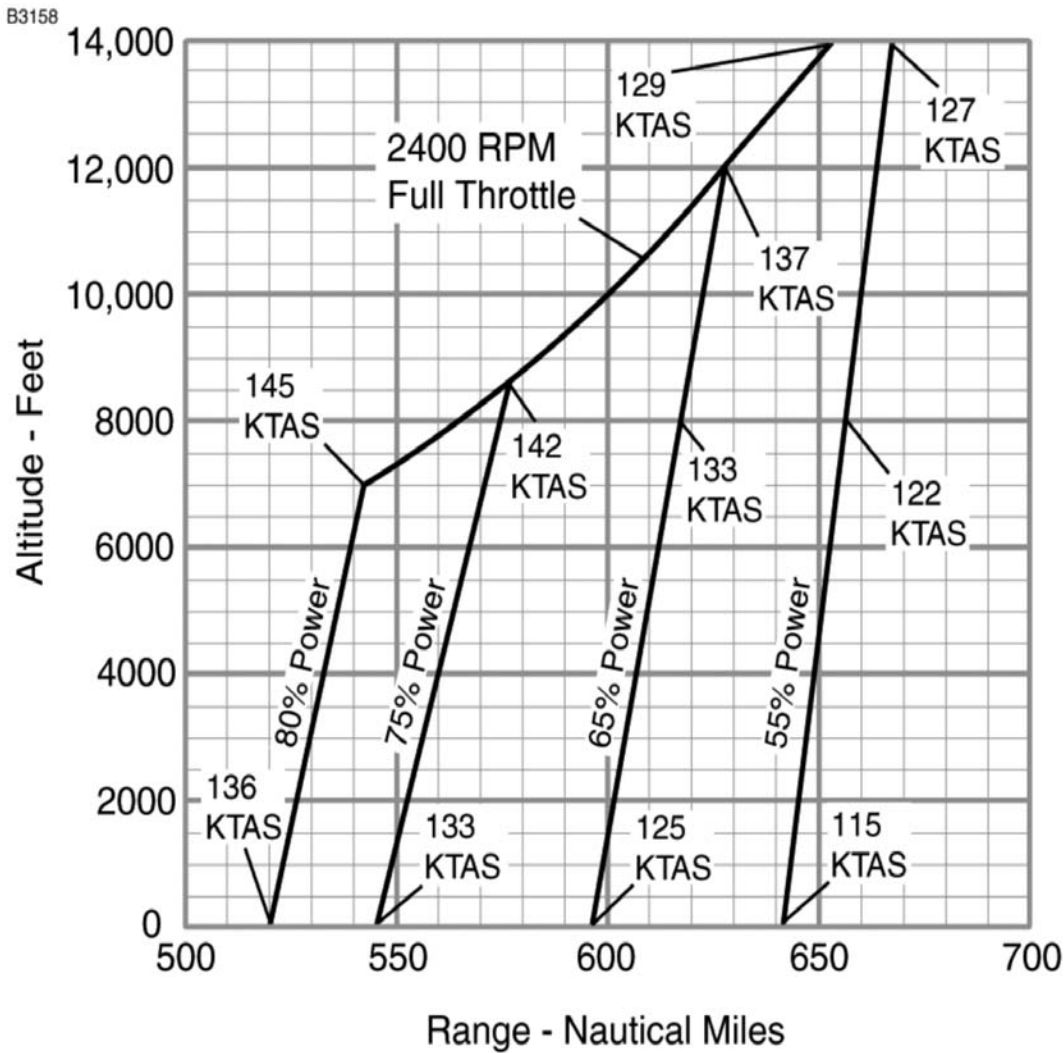

NOTE

This chart allows for the fuel used for engine start, taxi, takeoff and climb, and the distance during a normal climb up to 10,000 feet and maximum climb above 10,000 feet.

Figure 5-10 (Sheet 1 of 2)

RANGE PROFILE
45 MINUTES RESERVE
87 GALLONS USABLE FUEL

CONDITIONS:
3100 Pounds
Normal Climb to 10,000 feet then, Maximum Performance Climb, with Placard Mixture
Recommended Lean Mixture for Cruise
Standard Temperature
Zero Wind

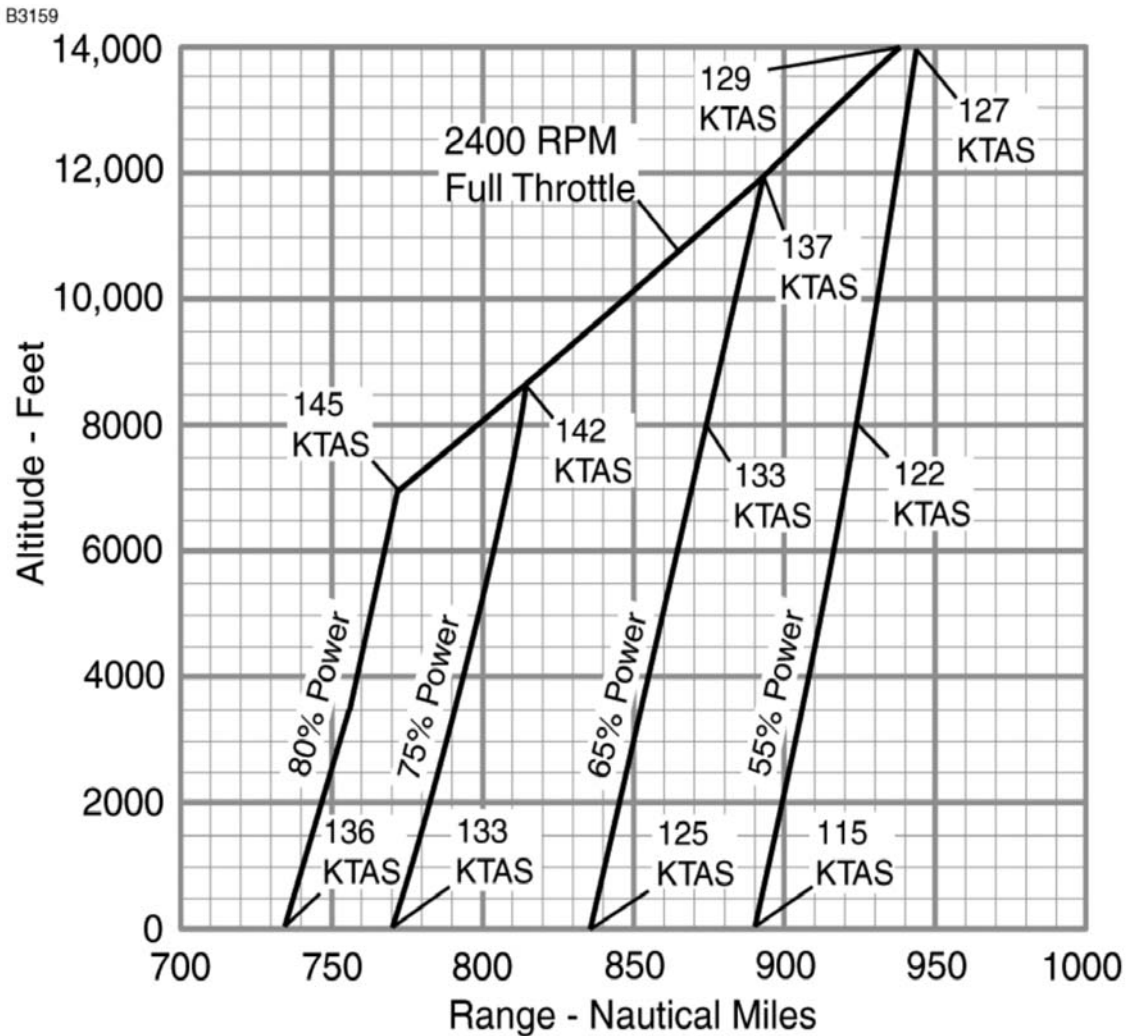

NOTE

This chart allows for the fuel used for engine start, taxi, takeoff and climb, and the distance during a normal climb up to 10,000 feet and maximum climb above 10,000 feet.

Figure 5-10 (Sheet 2)

ENDURANCE PROFILE

45 MINUTES RESERVE
64 GALLONS USABLE FUEL

CONDITIONS:
3100 Pounds
Normal Climb to 10,000 feet then, Maximum Performance Climb, with Placard Mixture
Recommended Lean Mixture for Cruise
Standard Temperature
Zero Wind

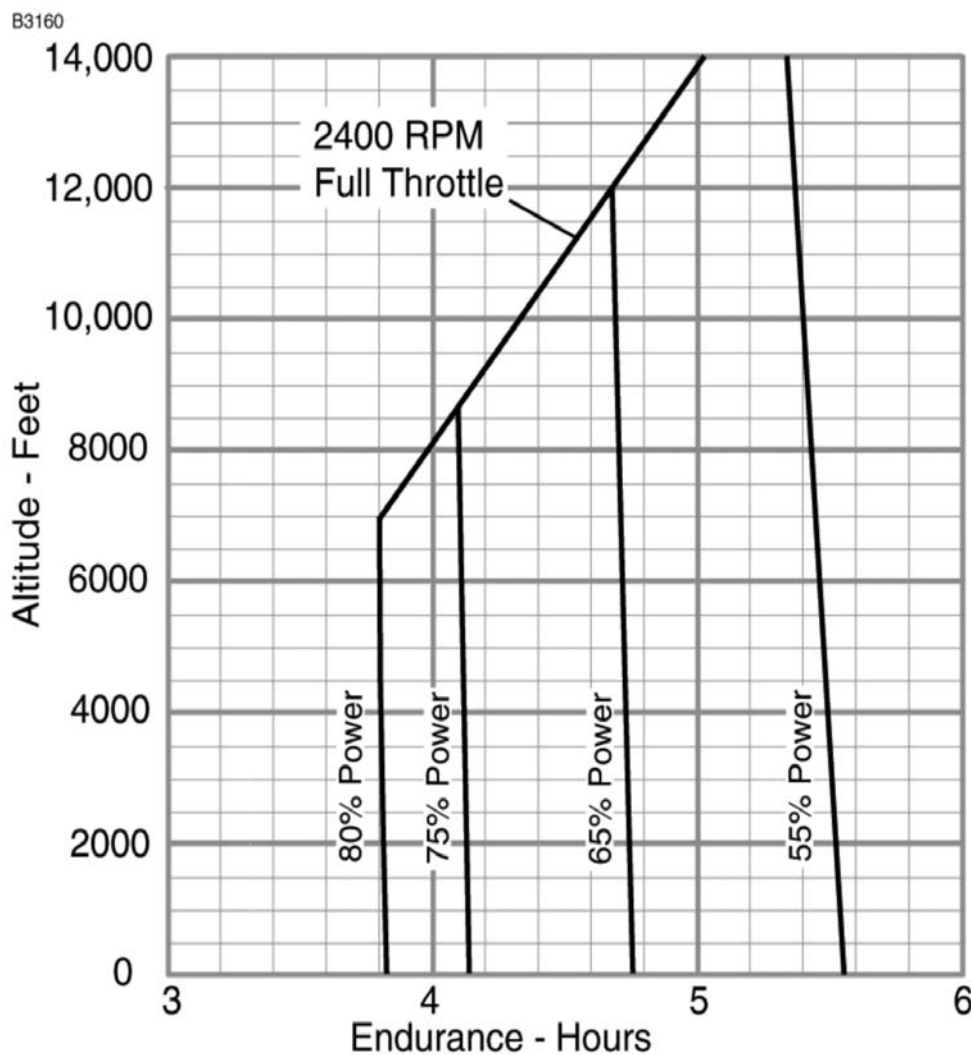

NOTE

This chart allows for the fuel used for engine start, taxi, takeoff and climb, and the distance during a normal climb up to 10,000 feet and maximum climb above 10,000 feet.

Figure 5-11 (Sheet 1 of 2)

ENDURANCE PROFILE
45 MINUTES RESERVE
87 GALLONS USABLE FUEL

CONDITIONS:
3100 Pounds
Normal Climb to 10,000 feet then, Maximum Performance Climb, with Placard
Mixture
Recommended Lean Mixture for Cruise
Standard Temperature
Zero Wind

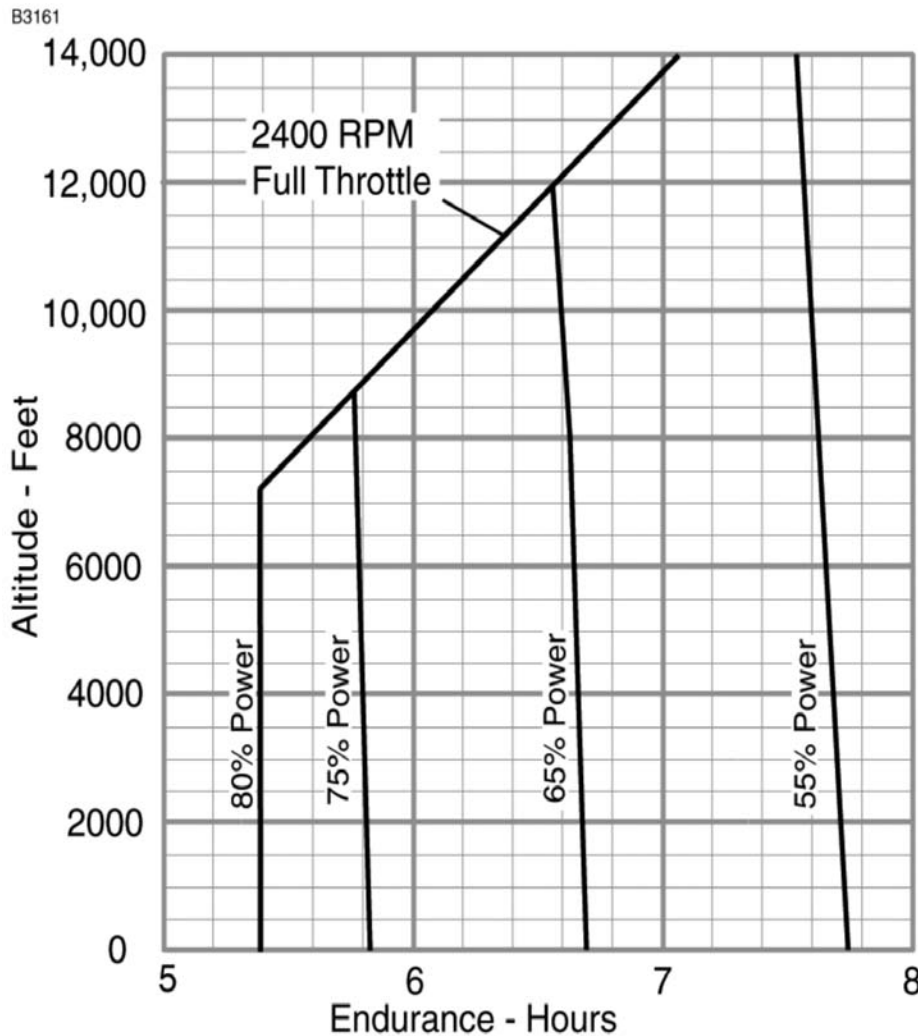

NOTE

This chart allows for the fuel used for engine start, taxi, takeoff and climb, and the distance during a normal climb up to 10,000 feet and maximum climb above 10,000 feet.

Figure 5-11 (Sheet 2)

SHORT FIELD LANDING DISTANCE AT 2950 POUNDS

CONDITIONS:

Flaps FULL
 Power IDLE
 Maximum Braking

Zero Wind
 Paved, Level, Dry Runway
 Speed at 50 ft: 60 KIAS

Pressure Altitude - Feet	0°C		10°C		20°C		30°C		40°C	
	Gnd Roll Feet	Total Feet To Clear 50 Foot Obst	Gnd Roll Feet	Total Feet To Clear 50 Foot Obst	Gnd Roll Feet	Total Feet To Clear 50 Foot Obst	Gnd Roll Feet	Total Feet To Clear 50 Foot Obst	Gnd Roll Feet	Total Feet To Clear 50 Foot Obst
Sea Level	560	1300	580	1335	600	1365	620	1400	640	1435
1000	580	1265	600	1365	620	1400	645	1440	665	1475
2000	600	1370	625	1405	645	1440	670	1480	690	1515
3000	625	1410	645	1445	670	1485	695	1525	715	1560
4000	650	1450	670	1485	695	1525	720	1565	740	1600
5000	670	1485	695	1525	720	1565	745	1610	770	1650
6000	700	1530	725	1575	750	1615	775	1660	800	1700
7000	725	1575	750	1615	780	1665	805	1710	830	1750
8000	755	1625	780	1655	810	1715	835	1760	865	1805

NOTE

- Short field technique as specified in Section 4.
- Decrease distances 10% for each 9 knots headwind. For operation with tail winds up to 10 knots, increase distances by 10% for each 2 knots.
- For operation on dry grass runway, increase distances by 45% of the “ground roll” figure.
- If landing with flaps up, increase the approach speed by 10 KIAS and allow for 40% longer distances.

Figure 5-12

WEIGHT AND BALANCE/ EQUIPMENT LIST

TABLE OF CONTENTS

	Page
Introduction	6-3
Airplane Weighing Procedures	6-3
Airplane Weighing Form	6-5
Sample Weight and Balance Record	6-7
Weight And Balance	6-8
Baggage Tiedown	6-9
Sample Loading Problem	6-11
Loading Graph	6-13
Loading Arrangements	6-14
Internal Cabin Dimensions	6-15
Center Of Gravity Moment Envelope	6-16
Center of Gravity Limits.	6-17/6-18
Comprehensive Equipment List	6-19

INTRODUCTION

This section describes the procedure for establishing the basic empty weight and moment of the airplane. Sample forms are provided for reference. Procedures for calculating the weight and moment for various operations are also provided. For additional information regarding Weight and Balance procedures, refer to the Aircraft Weight and Balance Handbook (FAA-H-8083-1). A comprehensive list of Cessna equipment available for this airplane is included at the back of this section.

Specific information regarding the weight, arm, moment and installed equipment for this airplane as delivered from the factory can be found in the plastic envelope in the back of this POH.

WARNING

IT IS THE RESPONSIBILITY OF THE PILOT TO MAKE SURE THE AIRPLANE IS LOADED PROPERLY. OPERATION OUTSIDE OF PRESCRIBED WEIGHT AND BALANCE LIMITATIONS COULD RESULT IN AN ACCIDENT AND SERIOUS OR FATAL INJURY.

AIRPLANE WEIGHING PROCEDURES

1. Preparation:
 - a. Inflate tires to recommended operating pressures.
 - b. Defuel airplane. Refer to the Maintenance Manual.
 - c. Service engine oil as required to obtain a normal full indication (approximately 8 quarts on dipstick).
 - d. Move sliding seats to the most forward position.
 - e. Raise flaps to the fully retracted position.
 - f. Place all control surfaces in neutral position.
 - g. Remove all non-required items from airplane.

(Continued Next Page)

AIRPLANE WEIGHING PROCEDURES (Continued)

2. Level:
 - a. Place scales under each wheel (minimum scale capacity, 1000 pounds).
 - b. Deflate the nose tire and/or lower or raise the nose strut to properly center the bubble in the level (Refer to Figure 6-1).
3. Weigh:
 - a. Weigh airplane in a closed hangar to avoid errors caused by air currents.
 - b. With the airplane level and brakes released, record the weight shown on each scale. Deduct the tare, if any, from each reading.
4. Measure:
 - a. Obtain measurement A by measuring horizontally (along the airplane centerline) from a line stretched between the main wheel centers to a plumb bob dropped from the firewall.
 - b. Obtain measurement B by measuring horizontally and parallel to the airplane centerline, from center of nosewheel axle, left side, to a plumb bob dropped from the line between the main wheel centers. Repeat on right side and average the measurements.
5. Using weights from step 3 and measurements from step 4, the Basic Empty Weight and C.G. can be determined by completing Figure 6-1 (Sheet 2).
6. Changes to the Airplane Weight and Balance due to alteration or repair must be documented in a permanent record within the POH similar to that shown in Figure 6-2.
7. A new Basic Empty Weight and CG Arm based on actual airplane weight (as weighed) is required after a major repair or alteration. It is recommended that the airplane be weighed to verify Basic Empty Weight and CG Arm at intervals not to exceed 5 years.

AIRPLANE WEIGHING FORM

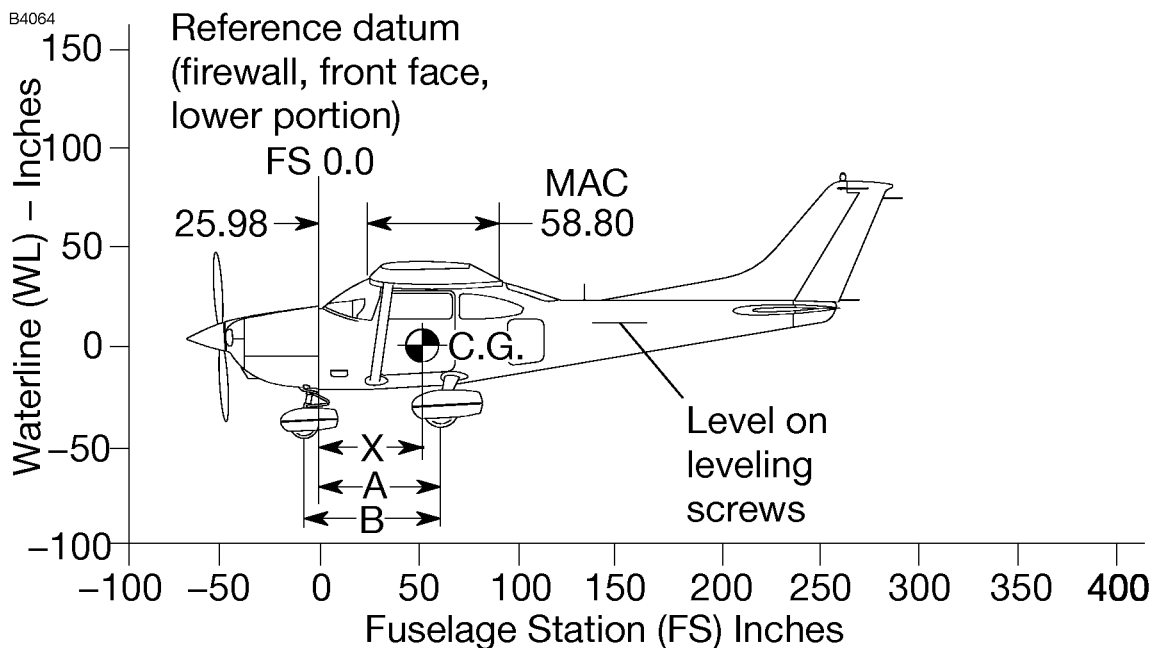

NOTE
It is the responsibility of the pilot to make sure that the airplane is loaded properly.

0785T1001

Figure 6-1 (Sheet 1 of 2)

AIRPLANE WEIGHING FORM

B4065

Locating CG with Airplane on Landing Gear

$$X \text{ (Inches Aft of Datum)} = A - \left[\frac{\text{Nosewheel Weight} \times B}{\text{Total Weight}^*} \right]$$

*(Nose + L + R Wheel Weights)

Locating Percent MAC

$$\text{CG Percent MAC} = \frac{(\text{CG Arm of Airplane}) - 25.98}{0.5880}$$

Measuring A and B

Leveling Provisions

Longitudinal – Left side of tailcone at FS 139.65 and 171.65

Measure A and B per pilot's operating handbook instructions to assist in locating CG with airplane weighed on landing gear.

Airplane as Weighed Table

Position	Scale reading	Scale drift	Tare	Net weight
Left Wheel				
Right Wheel				
Nose Wheel				
Airplane total as weighed				

Basic Empty Weight and Center-of-Gravity Table

Item	Weight Pounds	CG Arm (Inches)	Moment (Inch-Pounds /1000)
Airplane (calculated or as weighed) (includes all undrainable fluids and full oil)			
Drainable unusable fuel at 6.0 pounds per gallon – (5 gallons)	30.0	48.00	1.4
Basic Empty Weight			

Figure 6-1 (Sheet 2)

SAMPLE WEIGHT AND BALANCE RECORD

B3099

SAMPLE WEIGHT AND BALANCE RECORD

(Continuous history of changes in structure or equipment affecting weight and balance)

Airplane model		Serial number		Page number							
Date	Item no.	Description of article or modification	Weight change			Running basic empty weight					
			Removed (-)								
			Added (+)	Removed (-)	Running basic empty weight						
	In		WT. (lb.)	Arm (in.)	Moment /1000	WT. (lb.)	Arm (in.)	Moment /1000	WT. (lb.)	Arm (in.)	Moment /1000
		As delivered									

0585T1009

Figure 6-2

WEIGHT AND BALANCE

The following information will enable you to operate your Cessna within the prescribed weight and center of gravity limitations. To determine weight and balance, use the Sample Loading Problem (Figure 6-3), Loading Graph (Figure 6-4), and Center of Gravity Moment Envelope (Figure 6-7) as follows:

Enter the appropriate basic empty weight and moment/1000 from the weight and balance records for your airplane in the YOUR AIRPLANE column of the Sample Loading Problem.

NOTE

In addition to the basic empty weight and moment noted on these records, the C.G. arm (FS) is also shown, but need not be used on the Sample Loading Problem. The moment which is shown must be divided by 1000 and this value used as the moment/1000 on the loading problem.

Use the Loading Graph to determine the moment/1000 for each additional item to be carried; then list these on the loading problem.

NOTE

Loading Graph information for the pilot, passengers and baggage is based on seats positioned for average occupants and baggage loaded in the center of the baggage areas as shown on the Loading Arrangements diagram. For loadings which may differ from these, the Sample Loading Problem lists fuselage stations (FS) for these items to indicate their forward and aft C.G. range limitations (seat travel and baggage area limitation). Refer to Figures 6-5 and 6-6 for additional loading information. Additional moment calculations, based on the actual weight and C.G. arm (FS) of the item being loaded, must be made if the position of the load is different from that shown on the Loading Graph.

Total the weights and moments/1000 and plot these values on the Center of Gravity Moment Envelope to determine whether the point falls within the envelope, and if the loading is acceptable.

(Continued Next Page)

WEIGHT AND BALANCE (Continued)

BAGGAGE TIEDOWN

A nylon baggage net having four tiedown straps is provided as standard equipment to secure baggage in the area aft of the rear seat (baggage areas, A, B and C). Eight eyebolts serve as attaching points for the net. A placard on the baggage door defines the weight limitations in the baggage areas.

When baggage area A is utilized for baggage only, the four forward eyebolts should be used. When only baggage area B is used, the eyebolts just aft of the baggage door and the eyebolts above or below the shelf area may be used. When only baggage area C is utilized, the eyebolts above and below the shelf area should be used. When the cabin floor (baggage areas A and B) is utilized for baggage, the four forward eyebolts and the eyebolts mounted above or below the shelf area should be used. When there is baggage in areas B and C, the eyebolts just aft of the baggage door and the eyebolts above and below the shelf area should be used.

(Continued Next Page)

WEIGHT AND BALANCE (Continued)

BAGGAGE TIEDOWN (Continued)

When baggage is contained in all three areas, the two forward eyebolts on the cabin floor, the eyebolts just aft of the baggage door or the eyebolts at the bottom of the forward portion of the shelf area and the eyebolts near the upper forward surface of the shelf area should be used.

The rear bench seat can be removed to access the floorboard area of the rear cabin. Baggage may then be tied down using ten tiedown eyebolts to standard attach points located in the interior area of the airplane shown in Figure 6-6.

The maximum allowable floor loading of the rear cabin area is 200 pounds/square foot; however, when items with small or sharp support areas are carried, the installation of a plywood floor is recommended to protect the airplane structure.

The maximum rated load weight capacity for each of the ten tiedowns is 140 pounds. Rope, strap or cable used for tiedown should be rated at a minimum of ten times the load weight capacity of the tiedown fittings used. Weight and balance calculations for items in the area of the rear seat and baggage area can be figured on the Loading Graph using the lines labeled Rear Passengers or Cargo.

SAMPLE LOADING PROBLEM

ITEM DESCRIPTION	WEIGHT AND MOMENT TABULATION			
	SAMPLE AIRPLANE		YOUR AIRPLANE	
	Weight (lbs)	Moment (lb-ins/1000)	Weight (lbs)	Moment (lb-ins/1000)
1 - Basic Empty Weight (Use the data pertaining to your airplane as it is presently equipped. Includes unusable fuel and full oil)	1924	70.9		
2 - Usable Fuel (At 6 Lbs./Gal.)				
- Standard Fuel - 87 Gallons Maximum	522	24.3		
- Reduced Fuel - 64 Gallons				
3 - Pilot and Front Passenger (FS 32 to 50)	340	12.6		
4 - Rear Passengers (FS 74)	200	14.8		
Cargo - Replacing Rear Passenger Seat (FS 65 to 82)				
5 - *Baggage "A" (FS 82 to 109) 120 Pounds Maximum	100	9.7		
*Baggage "B" (FS 109 to 124) 80 Pounds Maximum	24	2.8		
*Baggage "C" (FS 124 to 134) 80 Pounds Maximum				
6 - RAMP WEIGHT AND MOMENT	3110	135.1		
7 - Fuel allowance for engine start, taxi and runup	-10.0	-0.5		
8 - TAKEOFF WEIGHT AND MOMENT (Subtract Step 7 from Step 6)	3100	134.6		

9 - Locate this point (3100 at 134.6) on the Center of Gravity Moment Envelope, and since this point falls within the envelope, the loading is acceptable, providing that flight time is allowed for fuel burn-off to a maximum of 2950 pounds before landing.

*The maximum allowable combined weight capacity for baggage in areas A, B and C is 200 pounds. The maximum allowable combined weight capacity in areas B and C is 80 pounds.

Figure 6-3 (Sheet 1 of 2)

LOADING GRAPH

B4066

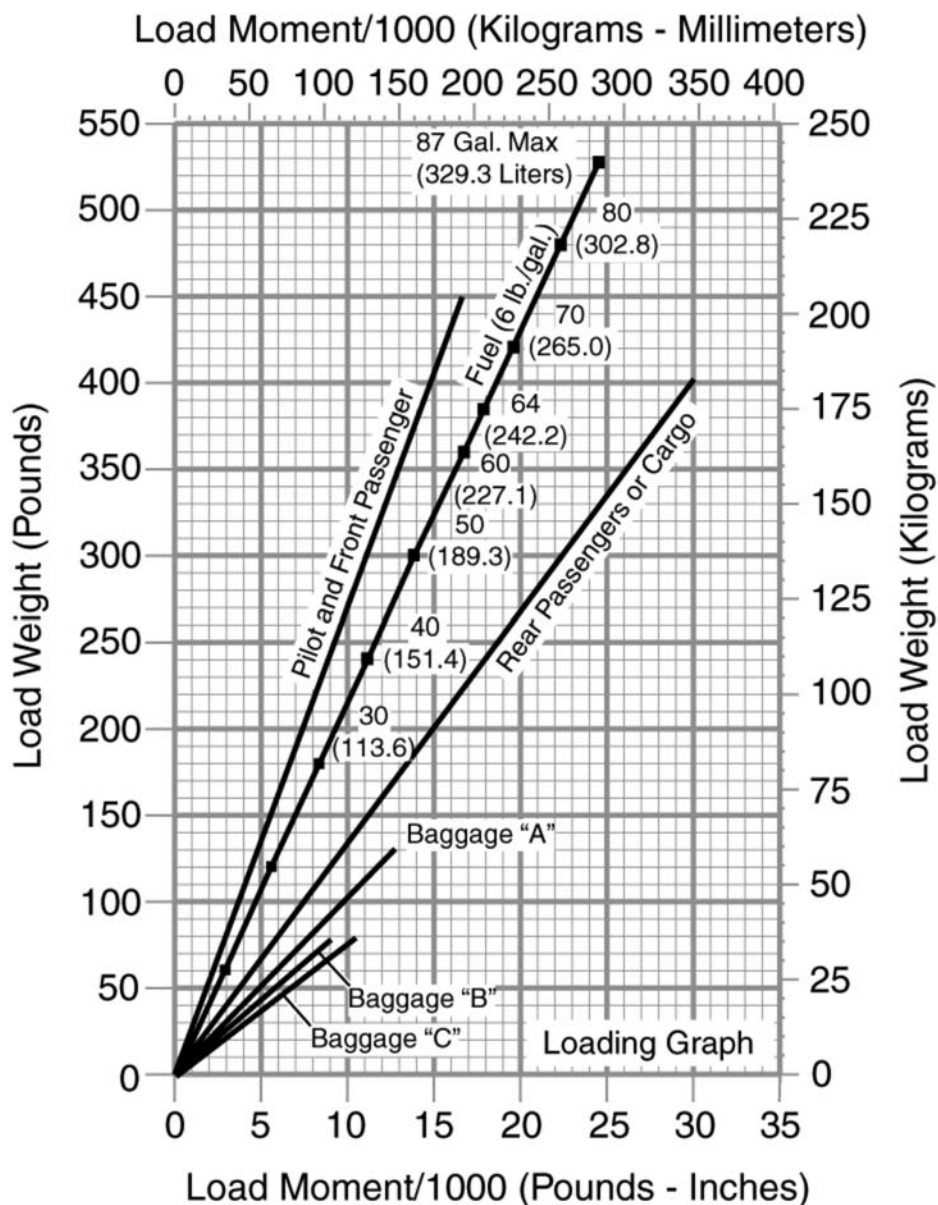

NOTE

Line representing adjustable seats shows the pilot and front seat passenger center of gravity on adjustable seats positioned for average occupant. Refer to the Loading Arrangements diagram for forward and aft limits of occupant C.G. range.

Figure 6-4

LOADING ARRANGEMENTS

B4067

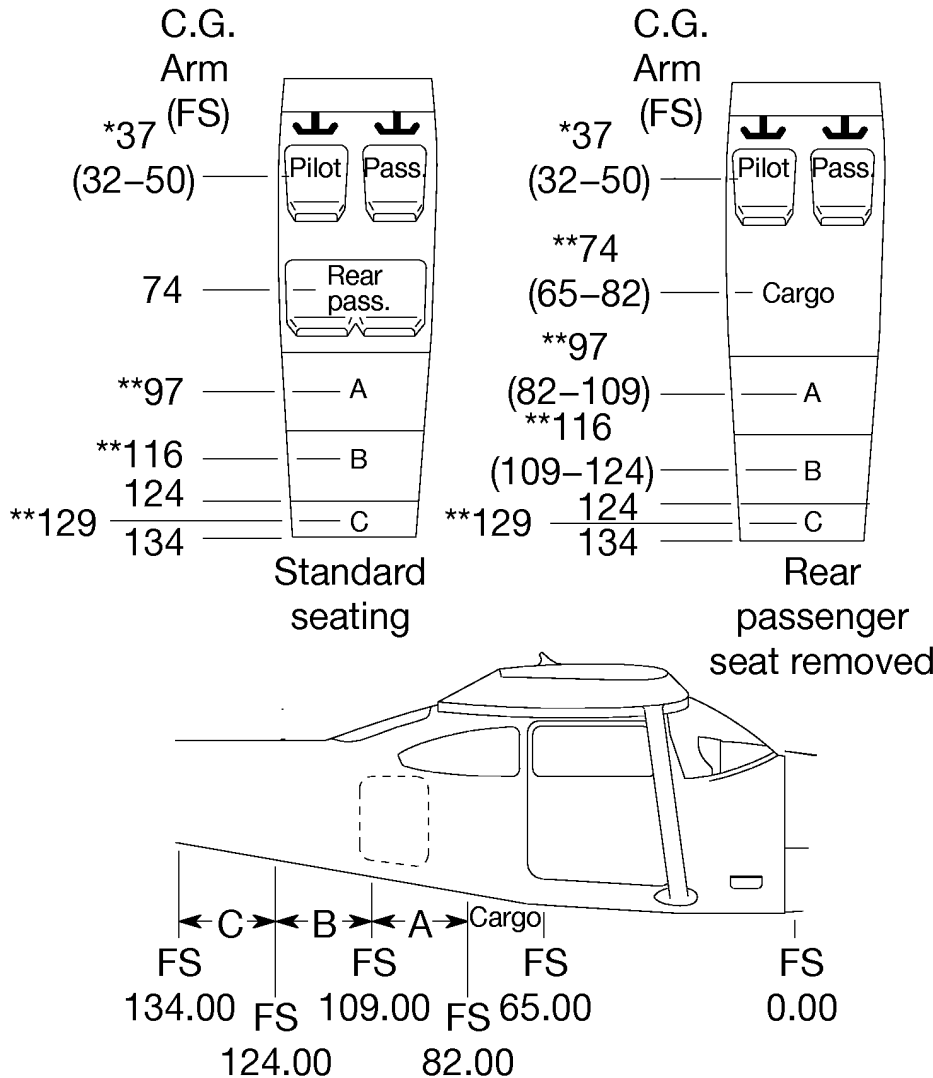

0785T1021

*Pilot or passenger center of gravity on adjustable seats positioned for average occupant. Numbers in parentheses indicate forward and aft limits of occupant center of gravity range.

*Arm measured to the center of the areas shown.

NOTE

- The usable fuel C.G. arm is located at FS 46.50.
- The aft baggage wall (approximate FS 134.00) can be used as a convenient interior reference point for determining the location of baggage area fuselage stations.

Figure 6-5

INTERNAL CABIN DIMENSIONS

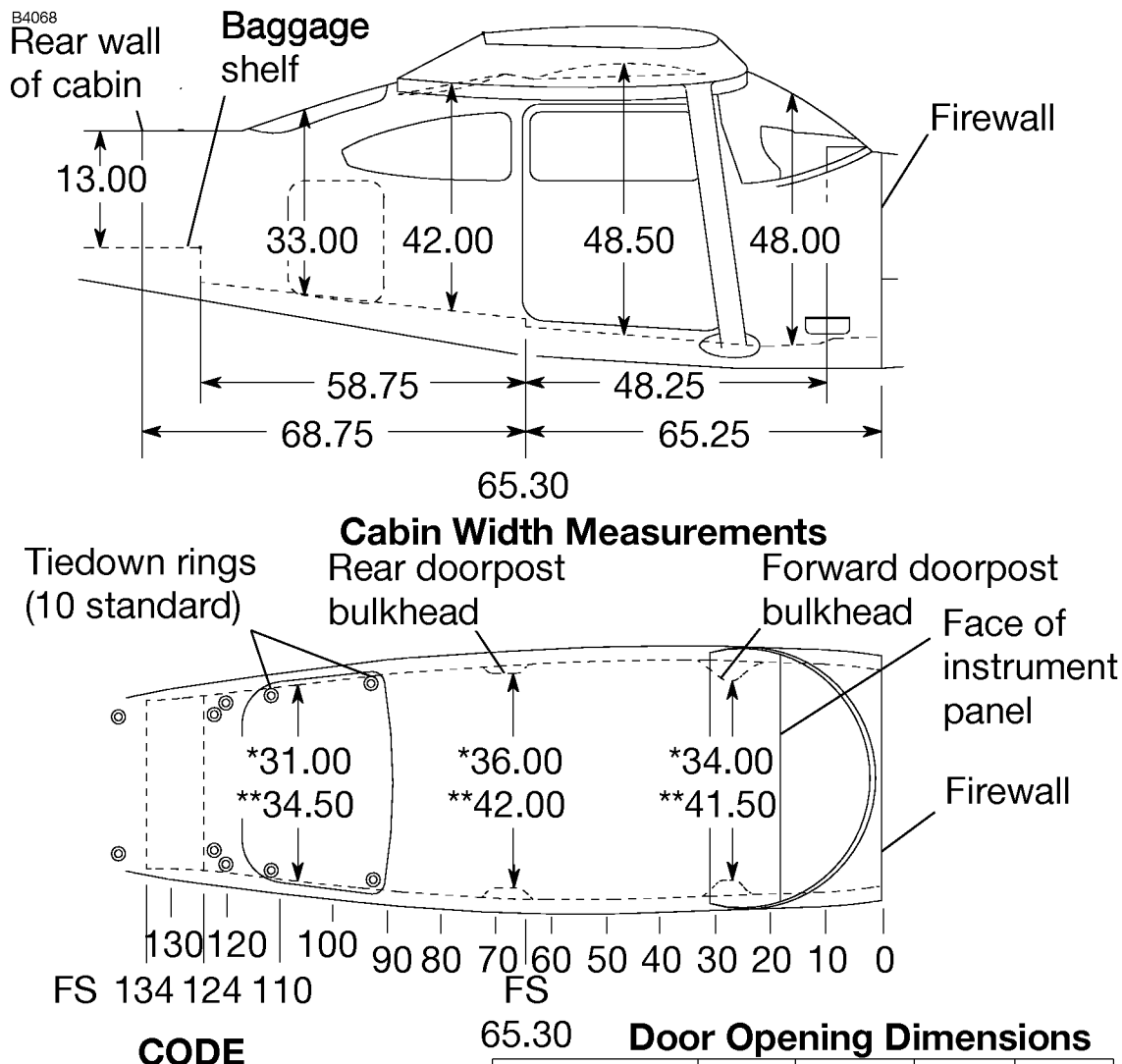

CODE
 *Cabin floor
 **Lower window line

	Width (top)	Width (bottom)	Height (front)	Height (rear)
Cabin doors	32.00	36.50	41.00	38.50
Baggage door	15.75	15.75	22.00	20.50

0785T1020

NOTE

- Maximum allowable floor loading is 200 pounds per square foot.
- All dimensions shown are in inches.

Figure 6-6

CENTER OF GRAVITY MOMENT ENVELOPE

B4069

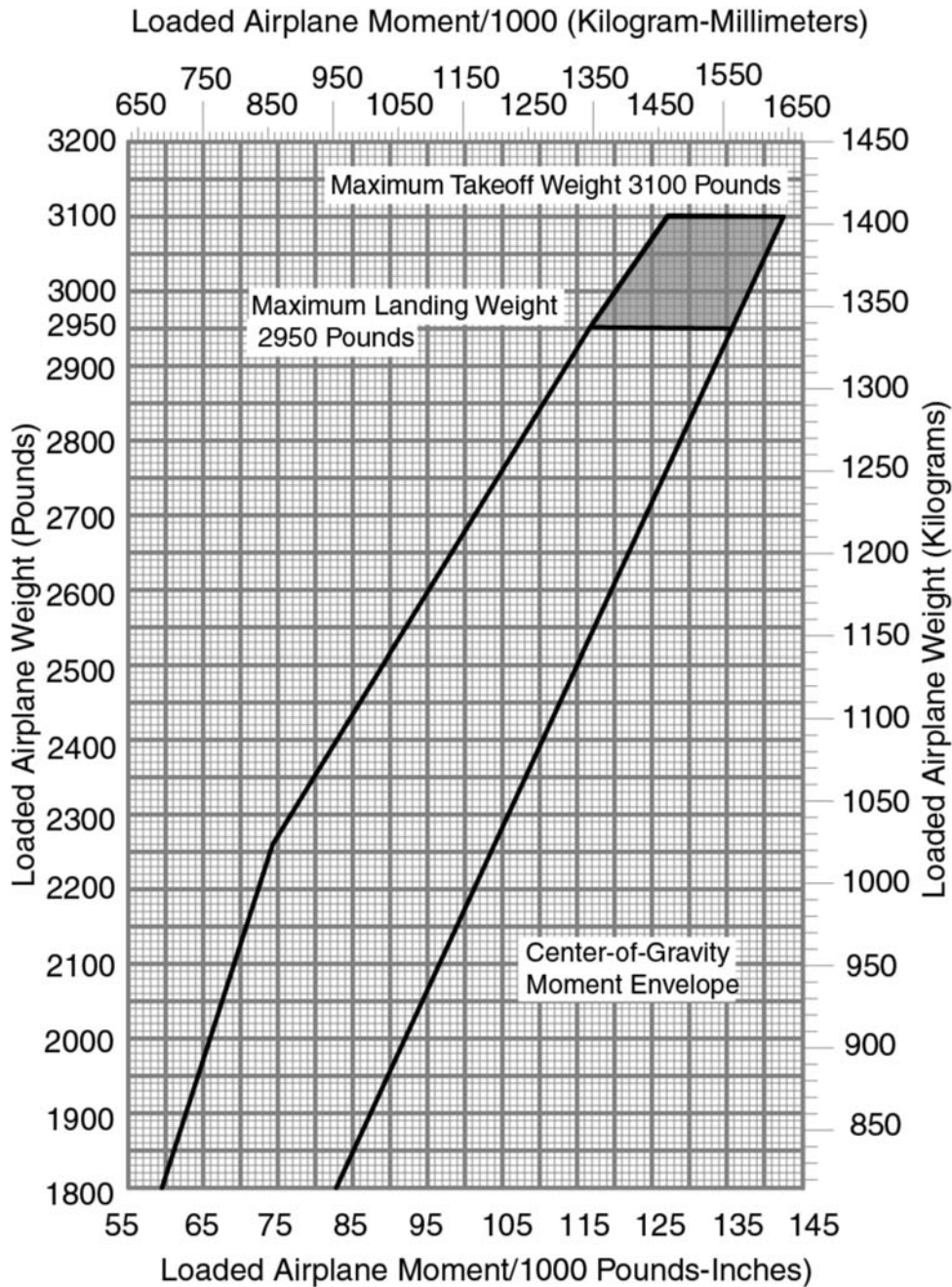

NOTE

If takeoff weight is more than maximum landing weight, allow flight time for fuel burn off to 2950 pounds before landing.

Figure 6-7

CENTER OF GRAVITY LIMITS

B4070

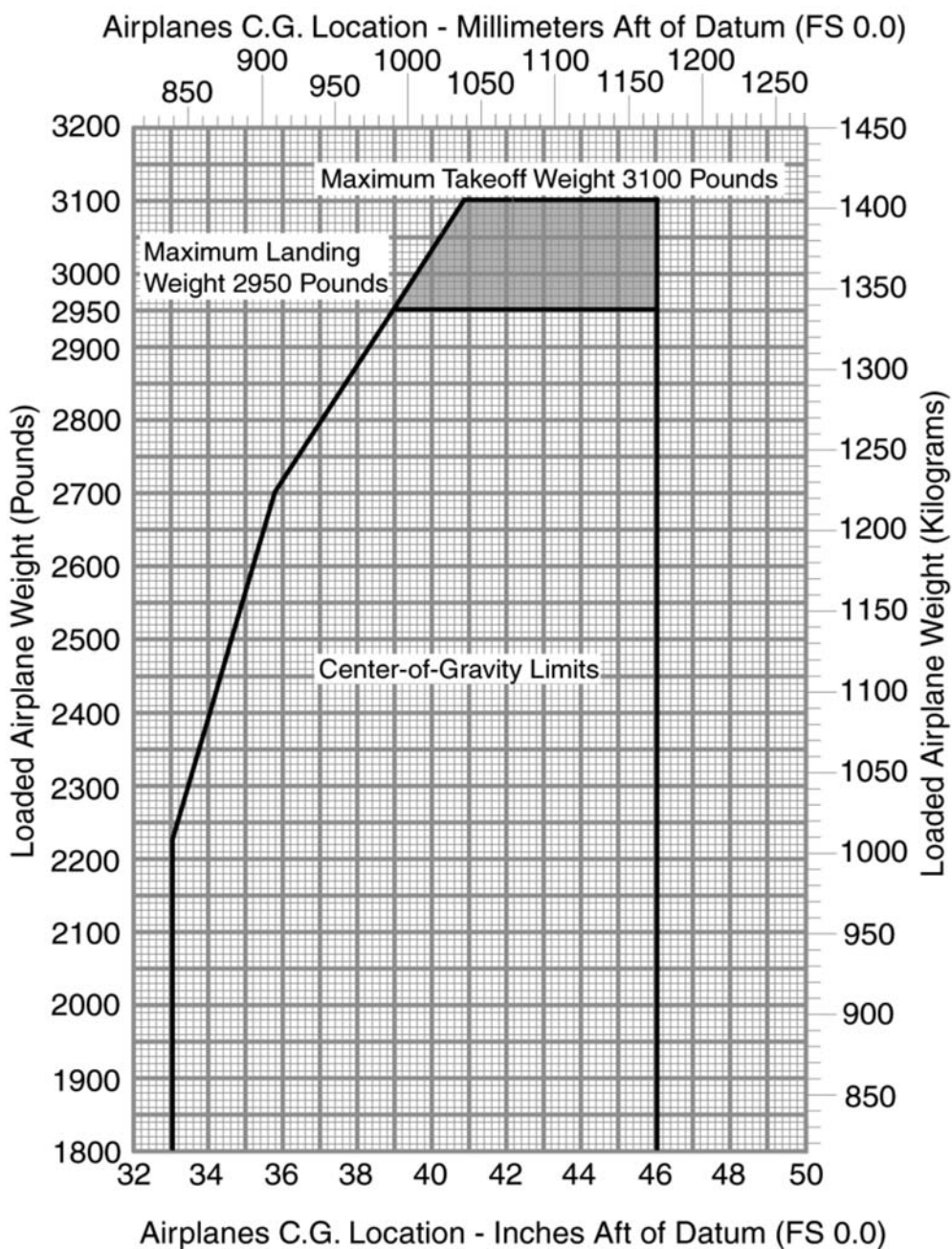

NOTE

If takeoff weight is more than maximum landing weight, allow flight time for fuel burn off to 2950 pounds before landing.

Figure 6-8

COMPREHENSIVE EQUIPMENT LIST

Figure 6-9 is a comprehensive list of all Cessna equipment which is available for the Model 182T airplane equipped with Garmin G1000 Integrated Cockpit System and GFC 700 Autopilot. This comprehensive equipment list provides the following information in column form:

In the **ITEM NO** column, each item is assigned a coded number. The first two digits of the code represent the identification of the item within Air Transport Association Specification 100 (11 for Paint and Placards; 24 for Electrical Power; 77 for Engine Indicating, etc.). These assignments also correspond to the Maintenance Manual chapter for the airplane. After the first two digits, items receive a unique sequence number (01, 02, 03, etc.). After the sequence number, a suffix letter is assigned to identify equipment as a required item, a standard item or an optional item.

Suffix letters are as follows:

- R = Required items or equipment for FAA certification (14 CFR 23 or 14 CFR 91).
- S = Standard equipment items.
- O = Optional equipment items replacing required or standard items.
- A = Optional equipment items which are in addition to required or standard items.

In the **EQUIPMENT LIST DESCRIPTION** column, each item is assigned a descriptive name to help identify its function.

In the **REF DRAWING** column, a Cessna drawing number is provided which corresponds to the item.

NOTE

If additional equipment is to be installed, it must be done in accordance with the reference drawing, service bulletin or a separate FAA approval.

In the **WT LBS** and **ARM INS** columns, information is provided on the weight (in pounds) and arm (in inches) of the equipment item.

NOTE

- Unless otherwise indicated, true values (not net change values) for the weight and arm are shown. Positive arms are distances aft of the airplane datum; negative arms are distances forward of the datum.
- Asterisks (*) in the weight and arm column indicate complete assembly installations. Some major components of the assembly are listed on the lines immediately following. The sum of these major components does not necessarily equal the complete assembly installation.

SECTION 6
WEIGHT AND BALANCE/
EQUIPMENT LIST

CESSNA
MODEL 182T NAV III
GFC 700 AFCS

ITEM NO	EQUIPMENT LIST DESCRIPTION	REF DRAWING	WT LBS	ARM INS.
11 - PAINT AND PLACARDS				
11-01-S	PAINT, OVERALL WHITE WITH COLOR STRIPE - OVERALL WHITE COLOR - COLOR STRIPING	0700810	19.6* 18.8 0.8	92.9* 91.5 135.9
21 - AIR CONDITIONING				
21-01-S	VENTILATORS, ADJUSTABLE, CABIN AIR	0719010	1.7	38.5
21-02-S	CABIN HEATER SYSTEM, SHROUDED MUFFLER TYPE	0750635	2.5	-29.5
21-03-R	FORWARD AVIONICS COOLING FAN - MC24B3	3930370	0.5	12.7
21-04-R	AFT AVIONICS COOLING FAN	3940389	1.1	125.5
22 - AUTO FLIGHT				
22-01-S	GFC 700 AUTOPILOT - PITCH SERVO - PITCH TRIM SERVO - ROLL SERVO	 3940452-1 3940454-1 3940453-1	6.9* 2.3 2.3 2.3	141.1* 185.9 176.4 61.0
23 - COMMUNICATIONS				
23-01-S	STATIC DISCHARGE WICKS, (SET OF 11)	1201131-2	0.3	152.9
23-02-R	AUDIO/INTERCOM/MARKER BEACON - GMA 1347 AUDIO PANEL - CI-102 MARKER BEACON ANTENNA	3930368 3910317-2 3960193-2	 2.6 0.5	 16.5 131.5
23-03-R	NAV/COM/GPS #1 COMPUTER - GIA 63W INTEGRATED AVIONICS UNIT - CI 2580-200 VHF COMM/GPS ANTENNA	3940389 3910317-4 3960222-7	 4.9 0.5	 134.0 61.2
23-04-S	NAV/COM/GPS #2 COMPUTER - GIA 63W INTEGRATED AVIONICS UNIT - CI 2580-410 VHF COMM/GPS/XM ANTENNA or - CI 2580-200 VHF COMM/GPS ANTENNA - CI 420-10 XM ANTENNA	3940389 3910317-4 3960222-8 3960222-9 3960234-1	 4.9 0.5 0.5 0.5	 134.0 61.2 61.2 41.5
24 - ELECTRICAL POWER				
24-01-R	ALTERNATOR, 28 VOLT, 60 AMP, -9910591-11	0750635	10.0	-33.4
24-02-O	ALTERNATOR, 28 VOLT, 95 AMP, -9910592-3	0750636	15.7	-33.4
24-03-R	BATTERY, 24 VOLT, 8.00 AMP HOUR	0718012	23.2	132.1
24-04-O	BATTERY, 24 VOLT, 10.00 AMP HOUR	0701169	27.2	132.1
24-05-R	POWER DISTRIBUTION MODULE S3100-366 - ALTERNATOR CONTROL UNIT - MASTER CONTACTOR - STARTER CONTACTOR - AMMETER TRANSDUCER	 AC2101 X61-0007 X61-0027 CS3200	6.4* 0.2 0.7 0.7 0.1	-2.5* -2.5 -2.5 -2.5 -2.0
24-06-S	BATTERY, STANDBY - AVT 200413, 24 VOLT, 6.20 AMP HOUR	0718023-1	14.0	10.8

Figure 6-9 (Sheet 1 of 6)

ITEM NO	EQUIPMENT LIST DESCRIPTION	REF DRAWING	WT LBS	ARM INS.
25 - EQUIPMENT/FURNISHINGS				
25-01-R	SEAT, PILOT, ADJUSTABLE, CLOTH/VINYL COVER	0719113-1	33.8	41.5
25-02-O	SEAT, PILOT, ADJUSTABLE, LEATHER/VINYL COVER	0719114-1	34.3	41.5
25-03-S	SEAT, FRONT PASSENGER, ADJUSTABLE, CLOTH/VINYL COVER	0719113-2	33.8	41.5
25-04-O	SEAT, FRONT PASSENGER, ADJUSTABLE, LEATHER/VINYL COVER	0719114-2	34.3	41.5
25-05-S	SEAT, REAR PASSENGER, TWO PIECE BACK, CLOTH/VINYL COVER	0719115-1	50.0	82.0
25-06-O	SEAT, REAR PASSENGER, TWO PIECE BACK, LEATHER/VINYL COVER	0719116-1	51.0	82.0
25-07-R	SEAT BELT AND SHOULDER HARNESS, INERTIA REEL, AUTO ADJUST, PILOT AND FRONT PASSENGER	0719087	5.2	50.3
25-08-S	SEAT BELT AND SHOULDER HARNESS, INERTIA REEL, AUTO ADJUST, REAR SEAT	0719087	5.2	87.8
25-09-S	SUN VISOR (SET OF 2)	0514166-3	1.2	33.0
25-10-S	BAGGAGE RESTRAINT NET	1215171-2	0.5	108.0
25-11-S	CARGO TIEDOWN RINGS (SET OF 10)	FD-2997M34-2	0.4	108.0
25-12-S	TOW BAR, NOSE GEAR (STOWED)	0501019-1	1.7	108.0
25-13-R	PILOT'S OPERATING HANDBOOK AND FAA APPROVED AIRPLANE FLIGHT MANUAL (STOWED IN FRONT PASSENGER'S SEAT BACK)	0700765-2	2.2	49.5
25-14-R	GARMIN G1000 COCKPIT REFERENCE GUIDE (STOWED IN COCKPIT SIDE PANEL POCKET)		1.5	15.0
25-15-O	APPROACH PLATE HOLDER	2619012-1	0.1	22.0
25-16-S	FUEL SAMPLING CUP (STOWED)	0500838-1	0.1	49.5
25-17-S	ARTEX ME406 - 2 FREQUENCY ELT	3940461-1	2.6*	137.7*
	- ELT TRANSMITTER	ME406	2.1	134.2
	- ANTENNA AND CABLE ASSY	110-338	0.5	152.4
25-18-O	ARTEX C406-N - 3 FREQUENCY ELT	3940462-1	5.1*	139.1*
	- ELT TRANSMITTER	C406-N	4.6	137.7
	- ANTENNA AND CABLE ASSY	110-338	0.5	152.4

Figure 6-9 (Sheet 2)

SECTION 6
WEIGHT AND BALANCE/
EQUIPMENT LIST

CESSNA
MODEL 182T NAV III
GFC 700 AFCS

ITEM NO	EQUIPMENT LIST DESCRIPTION	REF DRAWING	WT LBS	ARM INS.
26 - FIRE PROTECTION				
26-01-S	FIRE EXTINGUISHER	0501011-3	5.3*	29.0*
	- FIRE EXTINGUISHER, HAND TYPE	A352GS	4.8	29.0
	- MOUNTING CLAMP AND HARDWARE	1290010-1	0.5	29.0
27 - FLIGHT CONTROLS				
27-01-S	DUAL CONTROLS, RIGHT SEAT	0706015-1	5.9*	12.9*
	- CONTROL WHEEL, COPILOT	0713377-4	2.3	26.0
	- RUDDER AND BRAKE PEDAL, COPILOT	0760650-4	3.6	6.8
27-02-O	RUDDER PEDAL EXTENSION (SET OF 2) (INSTALLED ARM SHOWN)	0501082-2	2.9	8.0
28 - FUEL				
28-01-R	AUXILIARY FUEL PUMP - 5100-00-4	0716158	1.9	-12.0
28-02-R	FUEL SENDER, FLOAT TYPE - S3852-3, -4	0720701	0.1	56.3
	or			
	FUEL SENDER, VIBROMETER - 76-207-4, -5	0720701	0.9	56.3
30 - ICE AND RAIN PROTECTION				
30-02-S	STALL SENSOR HEAT AND PITOT HEAT	0720701	0.7	28.0
31 - INDICATING/RECORDING SYSTEM				
31-01-S	RECORDING HOURMETER - C664503-0103	0706015	0.5	16.7
31-02-R	STALL WARNING SYSTEM			
	- STALL WARNING HORN - 0718007-1	0718015	0.5	40.0
	- WING UNIT, STALL WARNING - S1672-9	0720701	0.3	25.6
31-03-R	GEA 71 ENGINE/AIRFRAME UNIT	3930368	2.2	11.4
31-04-R	GTP 59 OUTSIDE AIR TEMPERATURE (OAT) PROBE	0706015	0.1	41.5
32 - LANDING GEAR				
32-01-R	WHEEL BRAKE AND TIRE, 6.00 X 6 MAIN (2)	0741625-21	37.1*	58.6*
	- WHEEL ASSY CLEVELAND 40-75B (EACH)	C163001-0301	7.8	58.9
	- BRAKE ASSY CLEVELAND 30-52 (EACH)	030-05219-1	1.8	55.5
	- TIRE, 6-PLY (EACH)	C262003-0204	7.9	58.9
	- TUBE (EACH)	C262023-0102	1.3	58.9
32-02-R	WHEEL AND TIRE ASSY, 5.00 X 5 NOSE	0540000-2	8.8*	-7.1*
	- WHEEL ASSY CLEVELAND 40-77	1241156-12	2.8	-7.1
	- TIRE, 6-PLY	C262003-0202	4.6	-7.1
	- TUBE	C262023-0101	1.4	-7.1
32-03-A	WHEEL FAIRING AND INSTALLATION	0741650-1	16.4*	44.5*
	- WHEEL FAIRING, NOSE	0742411-1	3.1	-6.0
	- WHEEL FAIRINGS, MAIN (SET OF 2)	0741648-1, -2	9.5	60.6
32-04-A	HUB CAPS, WHEELS	0741048-8	0.1	62.1

Figure 6-9 (Sheet 3)

ITEM NO	EQUIPMENT LIST DESCRIPTION	REF DRAWING	WT LBS	ARM INS.
33 - LIGHTS				
33-01-S	MAP LIGHT IN CONTROL WHEEL	0760149-5	0.2	21.5
33-02-S	COURTESY LIGHTS UNDER WING	0700615-18	0.7	61.7
33-03-S	FLASHING BEACON, GROUND RECOGNITION	0701042-6, -7	0.8	253.1
33-04-R	STROBE LIGHT	0723207	3.2	40.4
33-05-S	LANDING AND TAXI LIGHT, HID	1221059-14, -15	2.2	26.8
34 - NAVIGATION				
34-01-R	STANDBY AIRSPEED INDICATOR - S3325-9	0706015	0.7	16.2
34-02-R	STANDBY ATTITUDE INDICATOR - S3326-6	0706015	2.2	14.0
34-03-R	STANDBY ALTIMETER, SENSITIVE WITH 20 FOOT MARKINGS, INCHES OF MERCURY AND MILLBARS - S3827-1	0706015	0.9	15.3
34-04-S	ALTERNATE STATIC AIR SOURCE	0701028-4	0.2	15.5
34-05-R	COMPASS, MAGNETIC	1213679-5	0.5	18.0
34-06-R	TRANSPONDER	3940389		
	- GTX-33 TRANSPONDER	3910317-5	3.6	134.0
	- CI 105-16 TRANSPONDER ANTENNA	3960195	0.4	86.5
34-07-R	PFD DISPLAY	3930374		
	- GDU-1044B DISPLAY	3910317-1	6.5	15.0
34-08-R	MFD DISPLAY	3930368		
	- GDU-1044B DISPLAY	3910317-1	6.5	15.0
34-09-R	ATTITUDE HEADING REFERENCE SENSOR (AHRS)	3940389		
	- GRS 77 AHRS	3910317-3	2.6	134.0
	- GMU 44 MAGNETOMETER	3940394	0.3	44.0
34-10-R	AIR DATA COMPUTER	3930368		
	- GDC 74A AIR DATA COMPUTER	3910317-6	3.6	11.4
34-11-O	WX 500 STORMSCOPE			
	- PROCESSOR - S3100-276	3940403	2.5	162.0
	- ANTENNA - 805-10930-001	3960206	1.0	175.4
34-12-S	GDL-69A DATALINK	3930368	2.8	11.4
34-13-O	AUTOMATIC DIRECTION FINDER (ADF)			
	- KR 87 ADF RECEIVER	3930495	3.2	12.2
	- ADF ANTENNA	3960192	4.2	39.3
34-14-O	DISTANCE MEASURING EQUIPMENT (DME)			
	- KN 63 REMOTE DME	3940449	2.8	177.2
	- CI 105-16 DME ANTENNA	3960232	0.4	114.5
34-15-O	KTA 810 TRAFFIC ADVISORY SYSTEM	3940441	8.8	165.0

Figure 6-9 (Sheet 4)

SECTION 6
WEIGHT AND BALANCE/
EQUIPMENT LIST

CESSNA
MODEL 182T NAV III
GFC 700 AFCS

ITEM NO	EQUIPMENT LIST DESCRIPTION	REF DRAWING	WT LBS	ARM INS.
37 - VACUUM				
37-01-R	ENGINE DRIVEN VACUUM PUMP			
	- VACUUM PUMP - AA3215CC	0706009	2.1	-5.0
	- COOLING SHROUD	1201998-1	0.2	-5.6
	- FILTER	1201075-2	0.3	11.5
	- VACUUM REGULATOR	AA2H3-2	0.5	2.1
37-02-R	VACUUM TRANSDUCER - P165-5786	0706015	0.3	8.5
53 - FUSELAGE				
53-01-S	REFUELING STEPS AND HANDLE	0701127-2	1.7	15.2
53-02-A	STABILIZER ABRASION BOOTS (SET OF 2)	0500041-3	0.6	206.0
56 - WINDOWS				
56-01-S	WINDOW, HINGED RIGHT SIDE	0711050-50	3.9	48.0
56-02-S	WINDOW, HINGED LEFT SIDE	0711050-49	3.9	48.0
61 - PROPELLER				
61-01-R	PROPELLER ASSEMBLY, 3-BLADE OIL FILLED HUB - P4317296-01 MCCAULEY B3D36C431/80VSA-1 (WEIGHT WITHOUT 30-01-S)	0750630	76.6	-47.5
61-02-R	- SPINNER, 3-BLADE - D-7261-1	0750630	4.1	-49.9
61-03-R	- GOVERNOR, PROPELLER - C161031-0119	0750635	2.7	-42.5
71 - POWERPLANT				
71-01-R	FILTER, INDUCTION AIR - P106150	0750635	1.3	-35.2
71-02-O	WINTERIZATION KIT (INSTALLED ARM SHOWN)	0752733-12	1.2	-42.0
72 - ENGINES				
72-01-R	ENGINE, LYCOMING IO-540-AB1A5	0750635-1	400.4*	-23.6*

Figure 6-9 (Sheet 5)

ITEM NO	EQUIPMENT LIST DESCRIPTION	REF DRAWING	WT LBS	ARM INS.
73 - ENGINE FUEL AND CONTROL				
73-01-R	MANIFOLD PRESSURE TRANSDUCER - P165-30A-E4C	0706015	0.1	-8.5
73-02-R	FUEL FLOW TRANSDUCER - 680501K	0701171	0.8	-12.4
77 - ENGINE INDICATING				
77-01-R	ENGINE TACHOMETER SENSOR - 1A3C-2	0701171	0.2	-8.0
77-02-R	CYLINDER HEAD THERMOCOUPLES (ALL CYLINDERS) - 32DKWUE006F0126	0701171	0.2	-12.0
77-03-S	EXHAUST THERMOCOUPLES (ALL CYLINDERS) - 86317	0701171	0.3	-12.0
78 - EXHAUST				
78-01-R	EXHAUST SYSTEM	0750635		
	- EXHAUST SYSTEM - LEFT	9954200-13	8.4	-24.2
	- EXHAUST SYSTEM - RIGHT	9954200-14	8.4	-24.2
79 - OIL				
79-01-R	OIL COOLER - 10610R	0750635	5.5	-11.4
79-02-R	OIL PRESSURE SENSOR - P165-5281	0750635	0.2	-12.9
79-03-R	OIL TEMPERATURE SENSOR - S2335-1	0750635	0.2	-6.4

Figure 6-9 (Sheet 6)

AIRPLANE AND SYSTEMS DESCRIPTION

TABLE OF CONTENTS

	Page
Introduction	7-5
Airframe	7-5
Flight Controls	7-6
Trim Systems	7-7
Manual Electric Trim	7-7
Instrument Panel	7-10
Pilot Panel Layout	7-10
Center Panel Layout	7-11
Right Panel Layout	7-13
Center Pedestal Layout	7-13
Flight Instruments	7-16
Attitude Indicator	7-17
Airspeed Indicator	7-18
Altimeter	7-18
Horizontal Situation Indicator	7-19
Vertical Speed Indicator	7-20
Ground Control	7-21
Wing Flap System	7-22
Landing Gear System	7-23
Baggage Compartment	7-23
Seats	7-24
Integrated Seat Belt/Shoulder Harness	7-25
Entrance Doors And Cabin Windows	7-27
Control Locks	7-28
Engine	7-29
Engine Controls	7-29
Engine Instruments	7-30
Manifold Pressure	7-31
RPM (Tachometer)	7-32
Fuel Flow	7-32
Oil Pressure	7-33
Oil Temperature	7-34

(Continued Next Page)

TABLE OF CONTENTS (Continued)

	Page
Cylinder Head Temperature	7-35
Exhaust Gas Temperature	7-36
New Engine Break-In And Operation	7-37
Engine Lubrication System	7-37
Ignition And Starter System	7-38
Air Induction System	7-38
Exhaust System	7-39
Fuel Injection System	7-39
Cooling System	7-40
Propeller	7-41
Fuel System	7-42
Fuel Distribution	7-43
Fuel Indicating System	7-43
Fuel Calculations	7-45
Auxiliary Fuel Pump Operation	7-47
Fuel Return System	7-48
Fuel Venting	7-48
Reduced Tank Capacity	7-48
Fuel Selector Valve	7-49
Fuel Drain Valves	7-50
Brake System	7-50
Electrical System	7-51
G1000 Annunciator Panel	7-55
Master Switch	7-55
Standby Battery Switch	7-56
Avionics Switch	7-56
Electrical System Monitoring And Annunciations	7-57
Bus Voltage (Voltmeters)	7-57
Ammeter	7-58
Standby Battery Annunciation	7-58
Low Voltage Annunciation	7-59
High Voltage Annunciation	7-60
Circuit Breakers And Fuses	7-61
External Power Receptacle	7-62

(Continued Next Page)

TABLE OF CONTENTS (Continued)

	Page
Lighting Systems	7-63
Exterior Lighting	7-63
Interior Lighting	7-64
Cabin Heating, Ventilating And Defrosting System	7-66
Pitot-Static System And Instruments	7-68
Vacuum System And Instruments	7-69
Attitude Indicator	7-69
Vacuum Indicator	7-69
Low Vacuum Annunciation	7-69
Clock/O.A.T. Indicator	7-71
Stall Warning System	7-71
Standard Avionics	7-72
Garmin Display Units (GDU)	7-72
Audio Panel (GMA)	7-73
Integrated Avionics Unit (GIA)	7-73
Attitude and Heading Reference System (AHRS) and Magnetometer (GRS)	7-73
Air Data Computer (GDC)	7-74
Engine Monitor (GEA)	7-74
Transponder (GTX)	7-74
XM Weather and Radio Data Link (GDL)	7-74
GFC 700 Automatic Flight Control System (AFCS)	7-75
Control Wheel Steering (CWS)	7-75
L3 Communications WX-500 Stormscope	7-77
Bendix/King KTA 870 Traffic Advisory/Multi-Hazard Awareness System	7-77
Avionics Support Equipment	7-78
Avionics Cooling Fans	7-78
Antennas	7-79
Microphone And Headset Installations	7-80
Auxiliary Audio Input Jack	7-81
12V Power Outlet	7-82
Static Dischargers	7-83
Cabin Features	7-84
Emergency Locator Transmitter (ELT)	7-84
Cabin Fire Extinguisher	7-84
Carbon Monoxide Detection System	7-85/7-86

INTRODUCTION

This section provides description and operation of the airplane and its systems. Some equipment described herein is optional and may not be installed in the airplane. Refer to Section 9, Supplements, for details of other optional systems and equipment.

AIRFRAME

The airplane is an all metal, four-place, high wing, single-engine airplane equipped with tricycle landing gear and is designed for general utility purposes.

The construction of the fuselage is a conventional formed sheet metal bulkhead, stringer, and skin design referred to as semimonocoque. Major items of structure are the front and rear carry through spars to which the wings are attached, a bulkhead and forgings for main landing gear attachment at the base of the rear door posts, and a bulkhead with attach fittings at the base of the forward door posts for the lower attachment of the wing struts. Four engine mount stringers are also attached to the forward door posts and extend forward to the firewall.

The externally braced wings, containing integral fuel tanks, are constructed of a front and rear spar with formed sheet metal ribs, doublers, and stringers. The entire structure is covered with aluminum skin. The front spars are equipped with wing-to-fuselage and wing-to-strut attach fittings. The aft spars are equipped with wing-to-fuselage attach fittings, and are partial span spars. Conventional hinged ailerons and single slot type flaps are attached to the trailing edge of the wings. The ailerons are constructed of a forward spar containing balance weights, formed sheet metal ribs and V type corrugated aluminum skin joined together at the trailing edge. The flaps are constructed basically the same as the ailerons, with the exception of the balance weights and the addition of a formed sheet metal leading edge section.

The empennage (tail assembly) consists of a conventional vertical stabilizer, rudder, horizontal stabilizer, and elevator. The vertical stabilizer consists of a forward and aft spar, formed sheet metal ribs and reinforcements, four skin panels, formed leading edge skins and a dorsal fin.

(Continued Next Page)

AIRFRAME (Continued)

The rudder is constructed of a forward and aft spar, formed sheet metal ribs and reinforcements, and a wrap-around skin panel. The top of the rudder incorporates a leading edge extension which contains a balance weight.

The horizontal stabilizer is constructed of a forward and aft spar, ribs and stiffeners, center upper and lower skin panels and two, left and two right wrap-around skin panels which also form the leading edges. The horizontal stabilizer also contains the elevator trim tab actuator.

Construction of the elevator consists of formed leading edge skins, a forward spar, ribs, torque tube and bellcrank, left upper and lower V type corrugated skins, and right upper and lower V type corrugated skins incorporating a trailing edge cut-out for the trim tab. Both elevator tip leading edge extensions incorporate balance weights. The elevator trim tab consists of a spar, rib, and upper and lower V type corrugated skins.

FLIGHT CONTROLS

The airplane's flight control system (Refer to Figure 7-1) consists of conventional aileron, rudder, and elevator control surfaces. The control surfaces are manually operated through mechanical linkage using a control wheel for the ailerons and elevator, and rudder/brake pedals for the rudder. The elevator control system is equipped with downsprings which provide improved stability in flight.

(Continued Next Page)

FLIGHT CONTROLS (Continued)

TRIM SYSTEMS

A manually operated rudder and elevator trim is provided (Refer to Figure 7-1). The rudder is trimmed through a bungee connected to the rudder control system and a trim control wheel mounted on the control pedestal. This is accomplished by rotating the horizontally mounted trim control wheel either left or right to the desired trim position. Rotating the trim wheel to the right will trim nose-right; conversely, rotating it to the left will trim nose-left. The elevator is trimmed through the elevator trim tab by utilizing the vertically mounted trim control wheel. Forward rotation of the trim wheel will trim nose-down, conversely, aft rotation will trim nose-up.

MANUAL ELECTRIC TRIM SYSTEM

Refer to the Garmin G1000 Cockpit Reference Guide (CRG) for more information on system operation.

(Continued Next Page)

FLIGHT CONTROLS AND TRIM SYSTEM

B6398

Aileron Control System

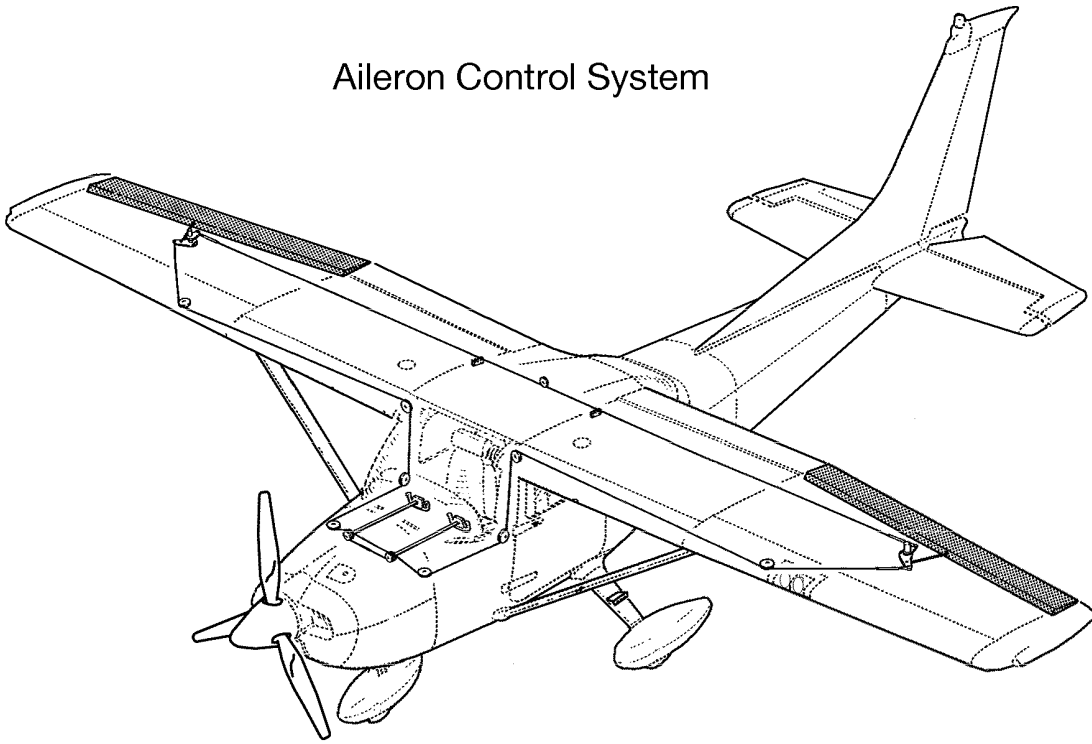

Rudder and Rudder Trim
Control Systems

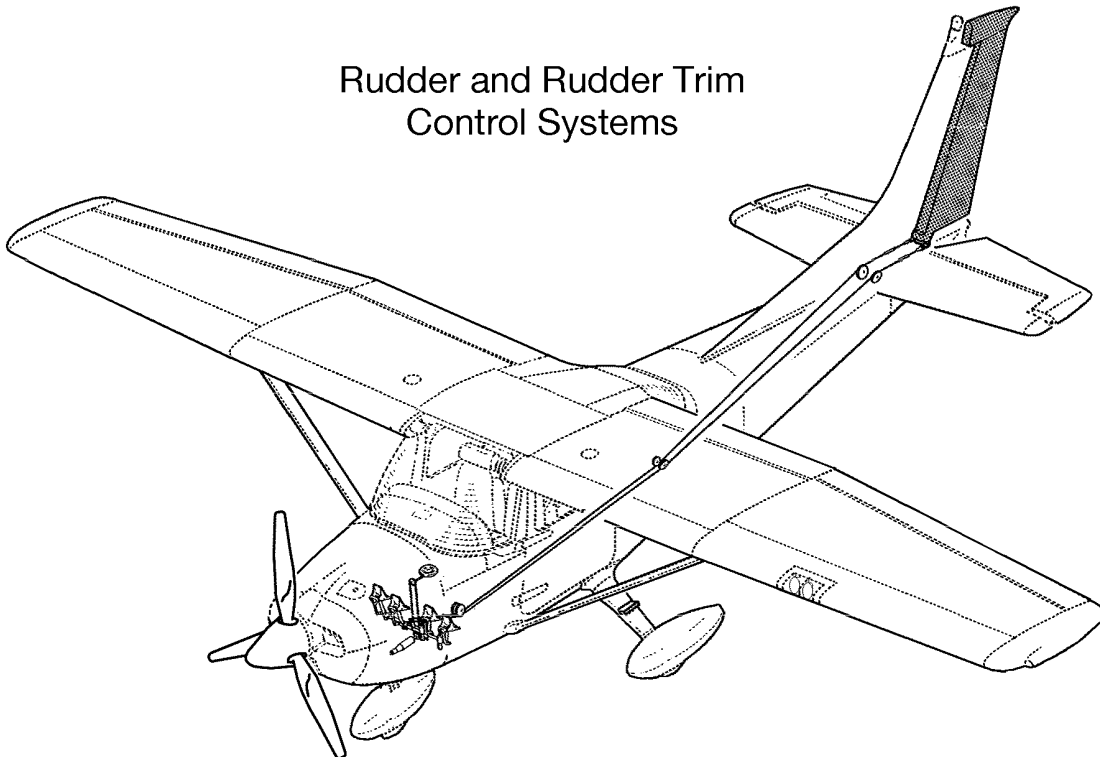
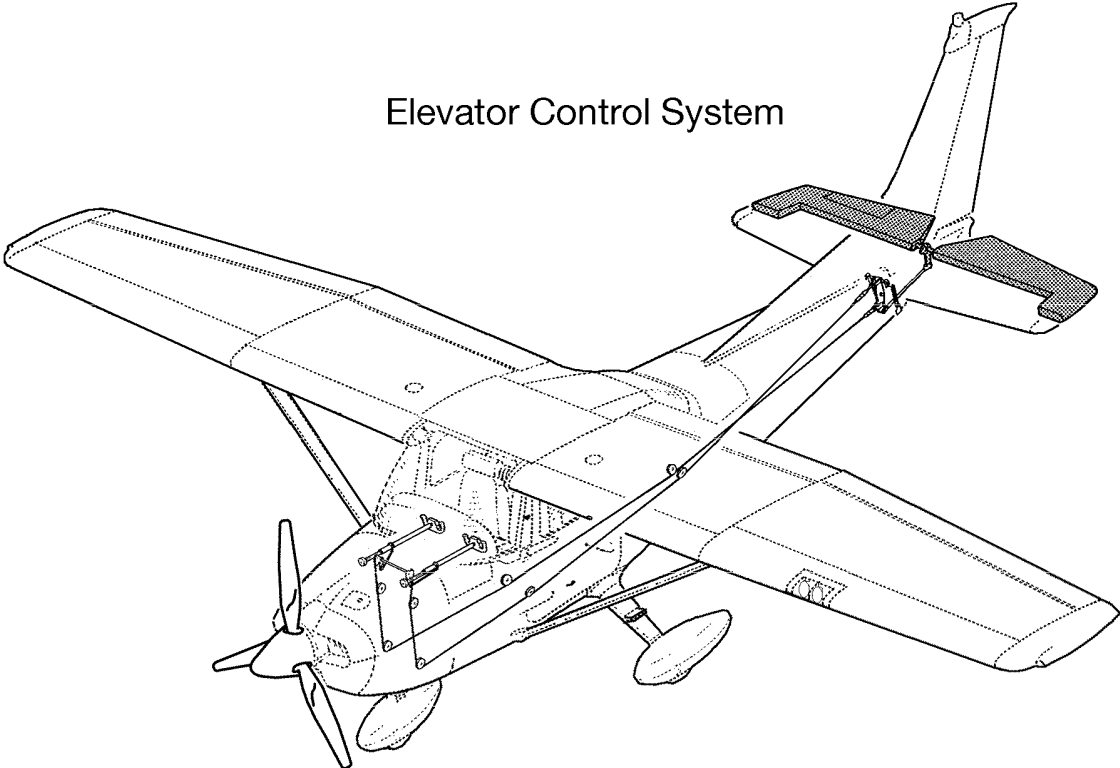

Figure 7-1 (Sheet 1 of 2)

FLIGHT CONTROLS AND TRIM SYSTEMS

B6399

Elevator Control System



Elevator Trim Control System

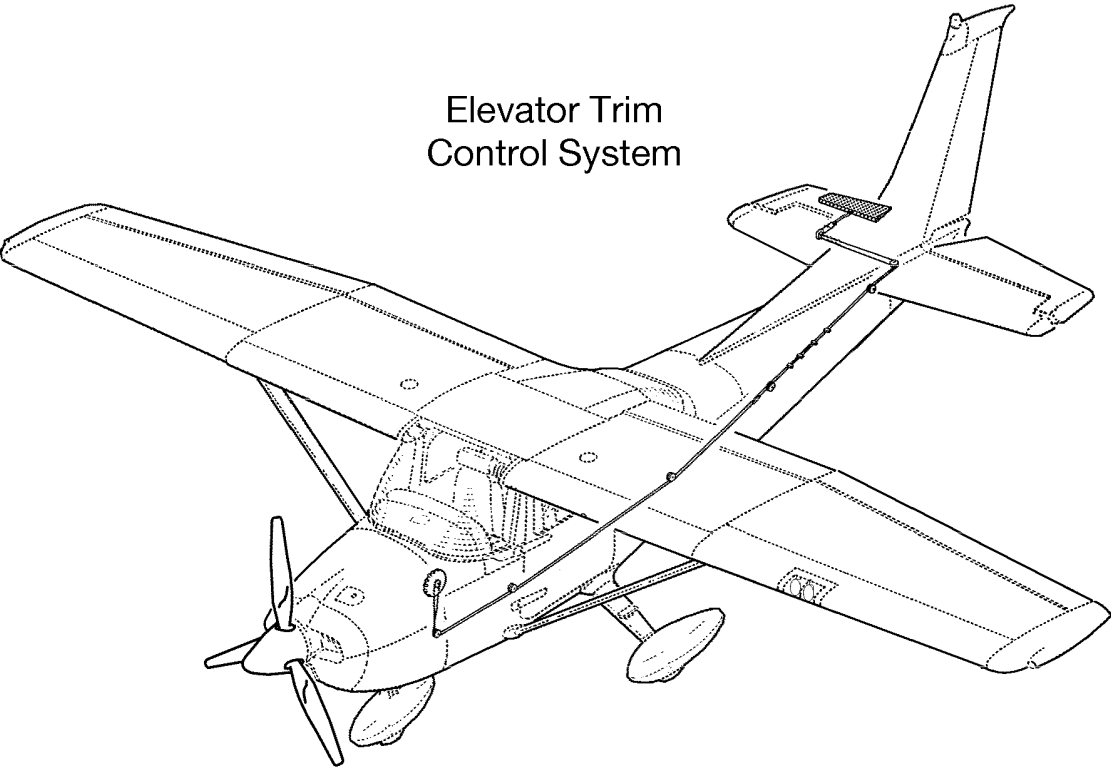

Figure 7-1 (Sheet 2)

INSTRUMENT PANEL

The instrument panel (Refer to Figure 7-2) is of all metal construction and is installed in sections so equipment can be easily removed for maintenance. The glareshield, above and projecting aft from the instrument panel, limits undesirable reflections on the windshield from lighted equipment and displays mounted in the instrument panel.

The Nav III instrument panel contains the Garmin Display Unit (GDU) Primary Flight Display (PFD) and Multifunction Display (MFD) and the Garmin Audio Panel. For specific details regarding the instruments, switches, circuit breakers and controls on the instrument panel, refer to the related topics in this section.

PILOT PANEL LAYOUT

The PFD, centered on the instrument panel in front of the pilot, shows the primary flight instruments during normal operation. During engine start, reversionary operation (MFD failure) or when the DISPLAY BACKUP switch is selected, the Engine Indication System (EIS) is shown on the PFD. Refer to the Garmin G1000 CRG for specific operating information.

The Standby Battery (STBY BATT) switch is found at the upper left corner of the pilot instrument panel on an internally lighted subpanel. The switch positions (ARM/OFF/TEST) select the standby battery operating modes. The rocker-type MASTER and AVIONICS switches are found immediately below the standby battery switch.

The controls for adjusting instrument panel, equipment, and pedestal lighting are found together on the subpanel below the MASTER and AVIONICS switches. See the INTERNAL LIGHTING paragraphs of this section for more information.

(Continued Next Page)

INSTRUMENT PANEL (Continued)

PILOT PANEL LAYOUT (Continued)

Switches for the airplane electrical systems and equipment are found on an internally lighted subpanel found below the lower left corner of the PFD. Each switch is labeled for function and is ON when the handle is in the up position. See the ELECTRICAL EQUIPMENT descriptions in this section for further information.

The circuit breaker panel is found along the lower edge of the pilot's instrument panel below the electrical equipment switch panel and pilot control wheel column. Each circuit breaker is identified for the equipment or function it controls and for the bus from which it receives power. Lighting for this subpanel is controlled using the SW/CB PANELS dimmer control. See the ELECTRICAL EQUIPMENT descriptions in this section for further information.

CENTER PANEL LAYOUT

The Garmin audio panel is found on the upper half of the center instrument panel, immediately to the right of the PFD. A pushbutton switch labeled DISPLAY BACKUP to manually select display reversion mode is found on the lower face of the audio panel. Refer to the Garmin G1000 CRG for operating information.

The MFD is found on the upper center panel to the right of the audio panel. The MFD depicts EIS information along the left side of the display and shows navigation, terrain, lightning and traffic data on the moving map. Flight management or display configuration information can be shown on the MFD in place of the moving map pages. Refer to the Garmin G1000 CRG for operating information.

(Continued Next Page)

INSTRUMENT PANEL (Continued)

CENTER PANEL LAYOUT (Continued)

The standby instrument cluster is in the center instrument panel below the audio panel. A conventional (mechanical) airspeed indicator and a sensitive aneroid altimeter are on each side of the vacuum-powered attitude indicator. The pitot-static instruments share the airplane pitot head and static ports with the air data computer. The attitude indicator features a low vacuum flag to provide immediate warning of vacuum system failure.

The engine controls are found on the lower center instrument panel below the standby instrument cluster. The controls are conventional push-pull-type controls and include throttle, prop RPM and mixture. See ENGINE description in this section for operating information.

The alternate static air valve is found adjacent to the throttle control. Refer to the PITOT-STATIC SYSTEM AND INSTRUMENTS description in this section for operating information.

The wing flap control lever and indicator are found at the lower right side of the center panel. Refer to the WING FLAP SYSTEM description in this section for operating information.

█ (Continued Next Page)

INSTRUMENT PANEL (Continued)

RIGHT PANEL LAYOUT

The Emergency Locator Transmitter (ELT) remote switch (ON/ARM/TEST RESET) is positioned at the upper inboard corner of the right panel adjacent to the MFD. Refer to Section 9, Supplements, for ELT operating information.

The Hour (Hobbs) meter is found to the right of the ELT switch and records engine operating time, when oil pressure is greater than 20 PSI, for maintenance purposes. Refer to the ENGINE INSTRUMENTS description in this section for further information.

CENTER PEDESTAL LAYOUT

The center pedestal, located below the center panel, contains the elevator and rudder trim control wheels, trim position indicators, cowl flap control lever, 12V power outlet, aux audio input jack and a bracket for the microphone. The fuel selector valve handle is located at the base of the pedestal.

INSTRUMENT PANEL

B6397

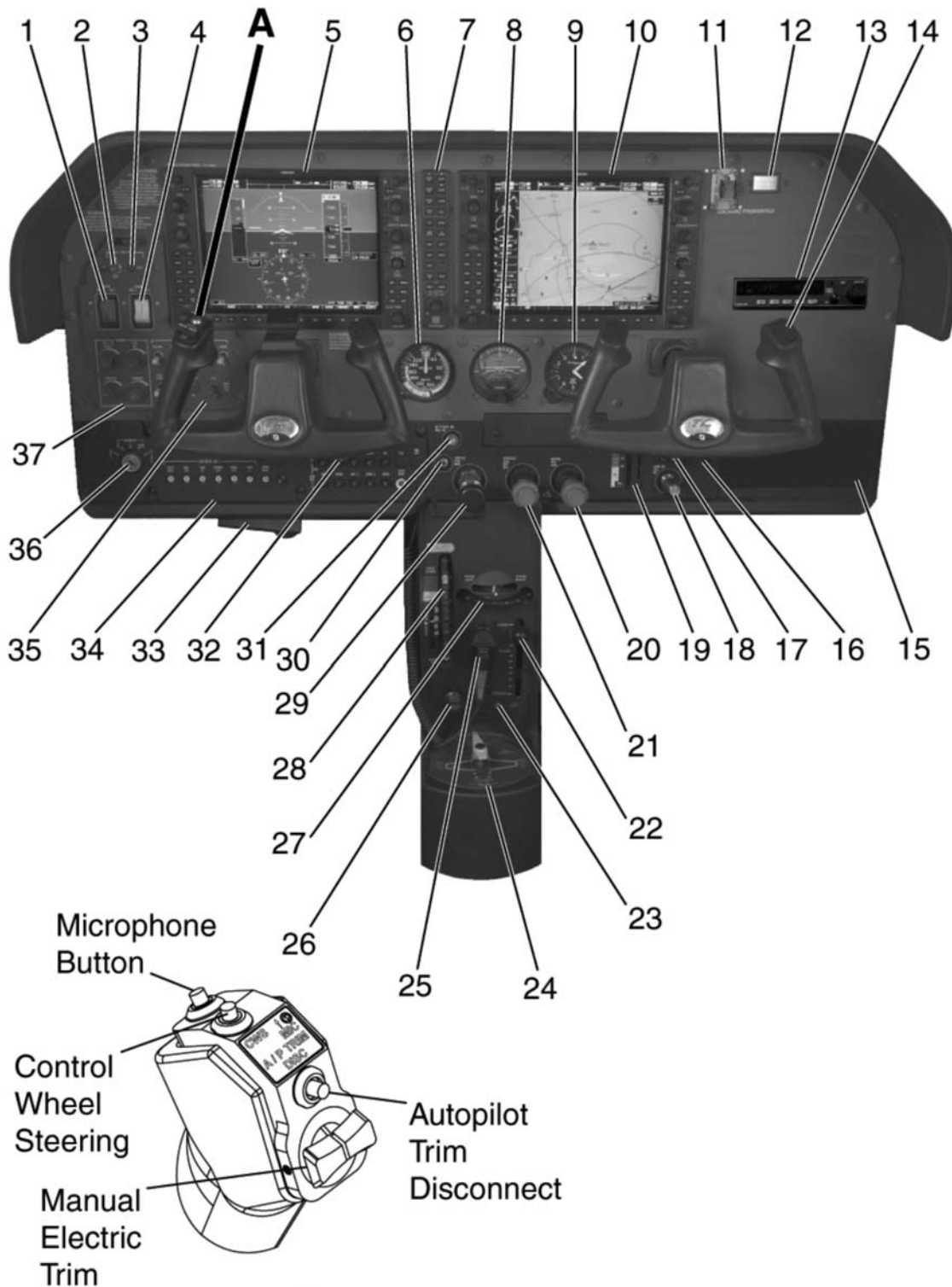

DETAIL A

0719P1058

Figure 7-2

INSTRUMENT PANEL

1. MASTER Switch (ALT and BAT)
2. STBY BATT Switch
3. STBY BATT Test Annunciator
4. AVIONICS Switch (BUS 1 and BUS 2)
5. Primary Flight Display
6. Standby Airspeed Indicator
7. Audio Control Panel
8. Standby Attitude Indicator
9. Standby Altimeter
10. Multifunction Display
11. ELT Remote Switch/Annunciator
12. Flight Hour Recorder
13. Bendix/King KR87 Automatic Direction Finder (if installed)
14. Microphone Button
15. Glove Box
16. Defroster Control
17. Cabin Heat Control
18. Cabin Air Control
19. Wing Flap Control Lever And Position Indicator
20. Mixture Control Knob
21. Propeller Control Knob
22. Cowl Flap Control Lever
23. Aux Audio Input Jack
24. Fuel Selector Valve
25. Handheld Microphone
26. 12V/10A Power Outlet
27. Rudder Trim Control Wheel And Position Indicator
28. Elevator Trim Control Wheel And Position Indicator
29. Throttle Control Knob (With Friction Lock)
30. Go-Around Button
31. ALT Static Air Valve Control
32. Yoke Mounted Map Light
33. Parking Brake Handle
34. Circuit Breaker Panel
35. Electrical Switch Panel
36. MAGNETOS/START Switch
37. DIMMING Panel

FLIGHT INSTRUMENTS

The G1000 Integrated Cockpit System primary flight instrument indications are shown on the PFD. The primary flight instruments are arranged on the PFD in the basic T configuration. The Attitude Indicator (AI) and Horizontal Situation Indicator (HSI) are centered vertically on the PFD and are conventional in appearance and operation. Vertical tape-style (scrolling scale) indicators with fixed pointers and digital displays, show airspeed, altitude, and vertical speed. The vertical indicators take the place of analog indicators with a fixed circular scale and rotating pointer.

Knobs, knob sets (two knobs on a common shaft) and membrane type push button switches, found on the bezel surrounding each GDU display, control COM, NAV, XPDR, AUTOPILOT, and GPS avionics, set BARO (barometric pressure), CRS (course), and HDG (heading), and work various flight management functions. Some push button switches are dedicated to certain functions (keys) while other switches have functions defined by software (softkeys). A softkey may perform various operations or functions at various times based on software definition. Softkeys are found along the lower bezel of the GDU displays.

(Continued Next Page)

FLIGHT INSTRUMENTS (Continued)

ATTITUDE INDICATOR

The G1000 attitude indicator is shown on the upper center of the PFD. The attitude indication data is provided by the Attitude and Heading Reference System (AHRS). The G1000 attitude indicator provides a horizon line that is the full width of the GDU display.

The roll index scale is conventional with 10° graduations to 30° and then 15° graduations to 60° of roll. The roll pointer is slaved to the airplane symbol. The pitch index scale is graduated in 5° increments with every 10° of pitch labeled. If pitch limits are exceeded in either the nose-up or nose-down direction, red warning chevrons will appear on the indicator to point the way back to level flight. A small white trapezoid located below the roll pointer moves laterally left and right to provide the slip-skid information previously supplied by the skid indicator ball. The trapezoid should be centered below the roll pointer for coordinated turns. The standby (vacuum) attitude indicator is found on the lower center instrument panel.

(Continued Next Page)

FLIGHT INSTRUMENTS (Continued)

AIRSPEED INDICATOR

The G1000 vertical tape airspeed indicator is shown along the upper left side of the PFD. The airspeed indication data is provided by the air data computer unit. Colored bands are provided to indicate the maximum speed, high cruise speed caution range, normal operating range, full wing flap operating range and low airspeed awareness band. Calculated true airspeed is displayed in a window at the bottom edge of the airspeed tape.

The standby (pneumatic) airspeed indicator is found on the lower center instrument panel. Colored arcs are provided to indicate the maximum speed, high cruise speed caution range, normal operating range, full wing flap operating range and low airspeed awareness band.

ALTIMETER

The primary altitude indicator (altimeter) is found along the right side of the attitude indicator on the PFD. The altitude indication data is provided by the air data computer unit. The local barometric pressure is set using the BARO knob on the GDU displays.

A cyan selectable altitude reference pointer, bug, is displayed on the altimeter tape and is set using the ALT SEL knob on the GDU displays. The altitude bug set-point is shown in a window at the top edge of the altimeter.

The standby (aneroid) sensitive altimeter is found on the lower center instrument panel.

(Continued Next Page)

FLIGHT INSTRUMENTS (Continued)

HORIZONTAL SITUATION INDICATOR

The Horizontal Situation Indicator (HSI) is found along the lower center area of the PFD. The heading indication data is provided by the AHRS and magnetometer units. The HSI combines a stabilized magnetic direction indicator (compass card) with selectable navigation deviation indicators for GPS or VHF navigation. The HSI is conventional in appearance and operation.

Magnetic heading is shown numerically in a window centered above the heading index (lubber line) at the top of the HSI. Reference index marks are provided at 45° intervals around the compass card. A circular segment scale below the heading window at the top of the HSI shows half and standard rates of turn based on the length of the magenta turn vector.

The cyan HSI heading reference pointer, bug, is set using the HDG knob on the GDU display. The selected heading is shown digitally in a window above the upper left 45° index mark. The selected heading will provide control input to the autopilot when engaged in HDG mode.

The CDI navigation source shown on the HSI is set using the CDI softkey to select from GPS, NAV 1 or NAV 2 inputs. The course reference pointer is set using the CRS knob on the GDU display. The selected course is shown digitally in a window above the upper right 45° index mark. The selected navigation source will provide control input to the autopilot when engaged in NAV, APR or BC mode and it is receiving a navigation signal from the selected GPS or VHF NAV radios.

(Continued Next Page)

FLIGHT INSTRUMENTS (Continued)

HORIZONTAL SITUATION INDICATOR (Continued)

WARNING

WHEN THE AUTOPILOT IS ENGAGED IN NAV, APR OR BC OPERATING MODES, IF THE HSI NAVIGATION SOURCE IS CHANGED MANUALLY, USING THE CDI SOFTKEY, THE CHANGE WILL INTERRUPT THE NAVIGATION SIGNAL TO THE AUTOPILOT AND WILL CAUSE THE AUTOPILOT TO REVERT TO ROL MODE OPERATION. NO AURAL ALERT WILL BE PROVIDED. IN ROL MODE, THE AUTOPILOT WILL ONLY KEEP THE WINGS LEVEL AND WILL NOT CORRECT THE AIRPLANE HEADING OR COURSE. SET THE HDG BUG TO THE CORRECT HEADING AND SELECT THE CORRECT NAVIGATION SOURCE ON THE HSI, USING THE CDI SOFTKEY, BEFORE ENGAGING THE AUTOPILOT IN ANY OTHER OPERATING MODE.

VERTICAL SPEED INDICATOR

The Vertical Speed Indicator (VSI) tape is found on the right side of the altimeter display along the upper right side of the PFD. The vertical speed pointer moves up and down the fixed VSI scale and shows the rate of climb or descent in digits inside the pointer. The VSI tape has a notch on the right edge at the 0 feet/min index for reference. Rate of descent is shown with a negative sign in front of the digits. Vertical speed must exceed 100 feet/min in climb or descent before digits will appear in the VSI pointer.

GROUND CONTROL

Effective ground control while taxiing is accomplished through nosewheel steering by using the rudder pedals; left rudder pedal to steer left and right rudder pedal to steer right. When a rudder pedal is depressed, a spring loaded steering bungee, which is connected to the nose gear and to the rudder bars, will turn the nosewheel through an arc of approximately 11° each side of center. By applying either left or right brake, the degree of turn may be increased up to 29° each side of center.

Moving the airplane by hand is most easily accomplished by attaching a towbar to the nose gear strut. If a towbar is not available, or pushing is required, use the wing struts as push points. Do not use the vertical or horizontal surfaces to move the airplane. If the airplane is to be towed by vehicle, never turn the nosewheel more than 29° either side of center or structural damage to the nose gear could result.

The minimum turning radius of the airplane, using differential braking and nosewheel steering during taxi, is approximately 27 feet. To obtain a minimum radius turn during ground handling, the airplane may be rotated around either main landing gear by pressing down on a tailcone bulkhead just forward of the horizontal stabilizer to raise the nosewheel off the ground. Care should be exercised to ensure that pressure is exerted only on the bulkhead area and not on skin between the bulkheads. Pressing down on the horizontal stabilizer to raise the nosewheel off the ground is not recommended.

WING FLAP SYSTEM

The single slot type wing flaps (Refer to Figure 7-3), are extended or retracted by positioning the wing flap control lever on the instrument panel to the desired flap deflection position. The wing flap control lever is moved up or down in a slotted panel that provides mechanical stops at the 10° and 20° positions. To change flap setting, the wing flap control lever is moved to the right to clear mechanical stops at the 10° and 20° positions. A scale and pointer to the left of the wing flap control lever indicates flap travel in degrees. The wing flap system circuit is protected by a 10-ampere circuit breaker, labeled FLAP, on the left side of the circuit breaker panel.

B6400

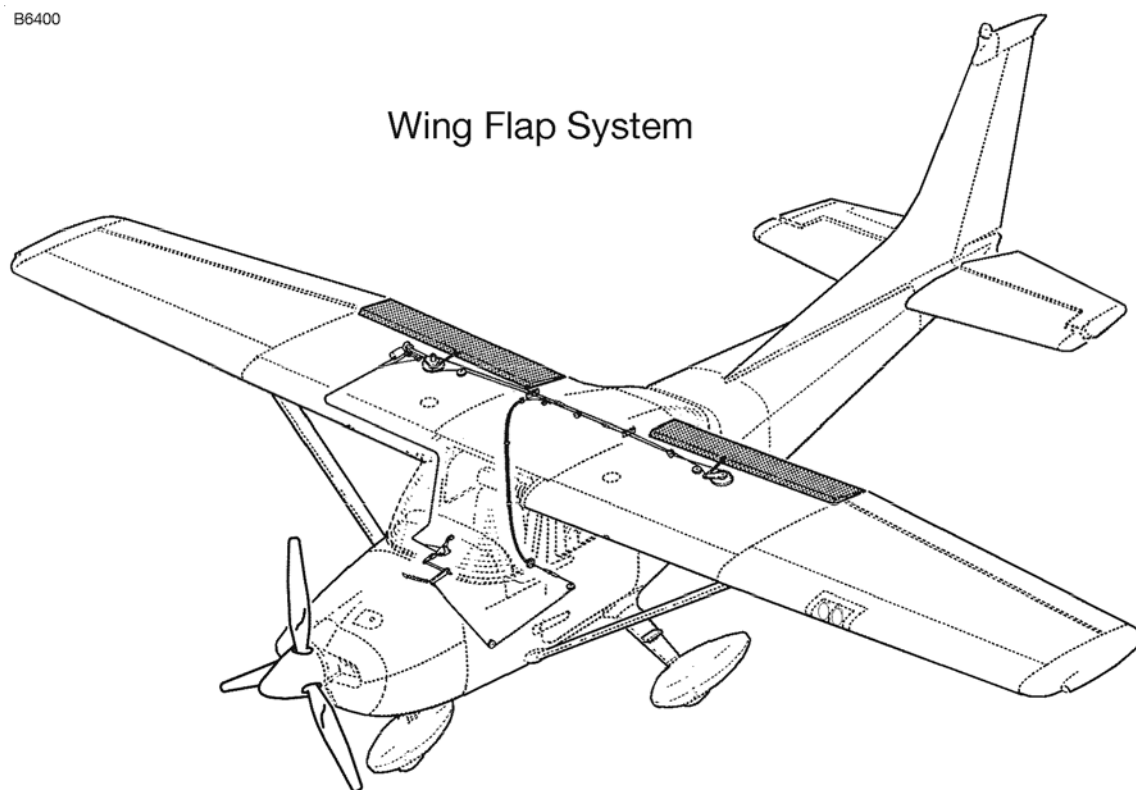

Figure 7-3

LANDING GEAR SYSTEM

The landing gear is of the tricycle type, with a steerable nosewheel and two main wheels. Wheel fairings are standard equipment for both the main wheels and nosewheel. Shock absorption is provided by the tubular spring steel main landing gear struts and the air/oil nose gear shock strut. Each main gear wheel is equipped with a hydraulically-actuated disc type brake on the inboard side of each wheel.

BAGGAGE COMPARTMENT

The baggage compartment consists of the area from the back of the rear passenger seats to the aft cabin bulkhead. Access to the baggage compartment is gained through a lockable baggage door on the left side of the airplane, or from within the airplane cabin. A baggage net with tiedown straps is provided for securing baggage and is attached by tying the straps to tiedown rings provided in the airplane. For baggage area and door dimensions, refer to Section 6.

SEATS

The seating arrangement consists of two vertically adjusting crew seats for the pilot and front seat passenger, and an infinitely adjustable split aft bench seat for rear seat passengers.

Seats used for the pilot and front seat passenger are adjustable forward and aft, and up and down. Additionally, the angle of the seat back is infinitely adjustable.

Forward and aft adjustment is made using the handle located below the center of the seat frame. To position the seat, lift the handle, slide the seat into position, release the handle and check that the seat is locked in place. To adjust the height of the seat, rotate the large crank under the right corner of the seat until a comfortable height is obtained. To adjust the seat back angle, pull up on the release button, located in center front of seat, just under the seat bottom, position the seat back to the desired angle, and release the button. When the seat is not occupied, the seat back will automatically fold forward whenever the release button is pulled up.

The rear passenger seat consists of a fixed, one piece seat bottom and an infinitely adjustable split back. Seat back controls are located beneath each seat bottom and provide adjustment for each seat back. To adjust the seat back, raise the lever, position the seat back to the desired angle, release the lever, and check that the seat back is securely locked in place.

Headrests are installed on both the front and rear seats. To adjust the headrest, apply enough pressure to it to raise or lower it to the desired level.

INTEGRATED SEAT BELT/SHOULDER HARNESS

All seat positions are equipped with integrated seat belts/shoulder harness assemblies (Refer to Figure 7-4). The design incorporates an overhead inertia reel for the shoulder portion, and a retractor assembly for the lap portion of the belt. This design allows for complete freedom of movement of the upper torso area while providing restraint in the lap belt area. In the event of a sudden deceleration, reels lock up to provide positive restraint for the user.

In the front seats, the inertia reels are located on the centerline of the upper cabin area. In the rear seats, the inertia reels are located outboard of each passenger in the upper cabin.

To use the integrated seat belt/shoulder harness, grasp the link with one hand, and, in a single motion, extend the assembly and insert into the buckle. Positive locking has occurred when a distinctive “snap” sound is heard.

Proper locking of the lap belt can be verified by ensuring that the belts are allowed to retract into the retractors and the lap belt is snug and low on the waist as worn normally during flight. No more than one additional inch of belt should be able to be pulled out of the retractor once the lap belt is in place on the occupant. If more than one additional inch of belt can be pulled out of the retractor, the occupant is too small for the installed restraint system and the seat should not be occupied until the occupant is properly restrained.

Removal is accomplished by pressing the release button on the buckle and pulling out and up on the harness. Spring tension on the inertia reel will automatically stow the harness.

INTEGRATED SEAT BELT/SHOULDER HARNESS

B6395

Standard Intergrated Seat
Belt/Shoulder Harness with
Inertia Reel

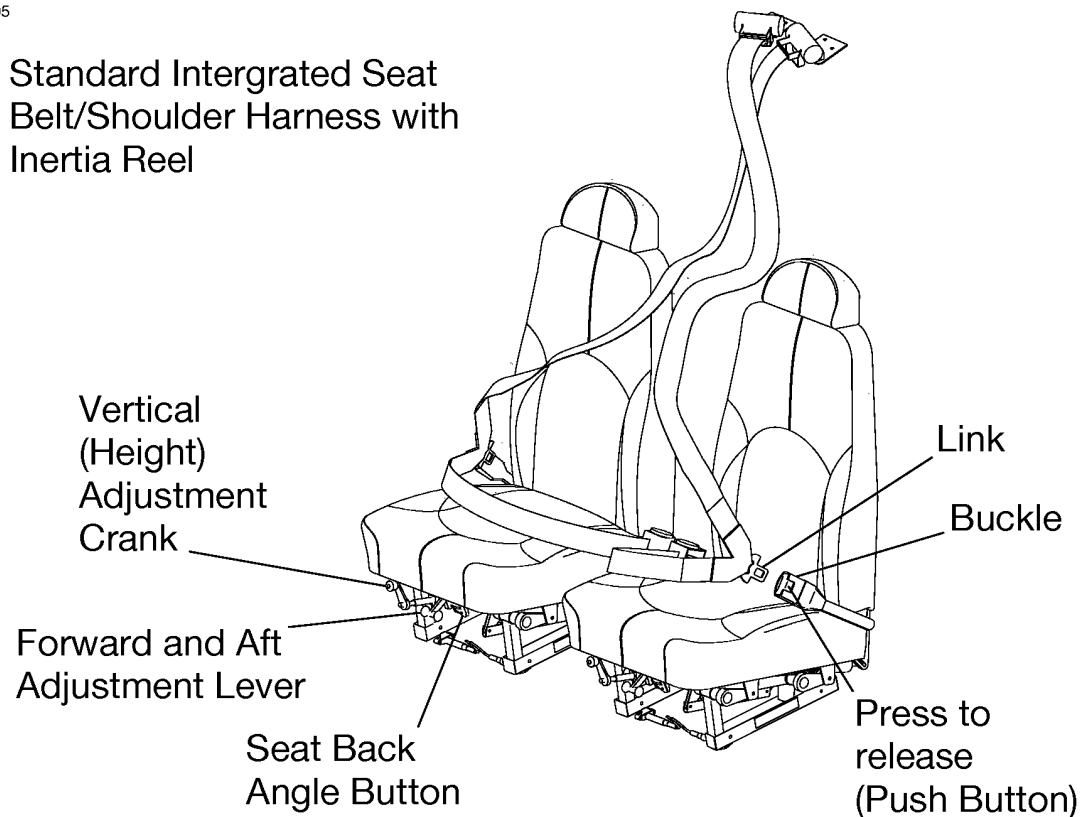

Pilot and Front Passenger Seat

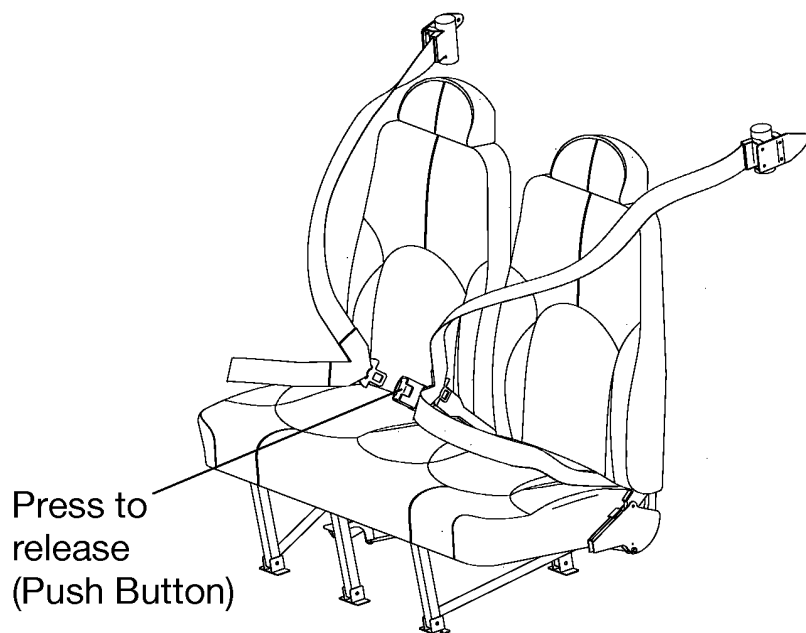

Aft Seat

0519T1111
0719T1059

Figure 7-4*

ENTRANCE DOORS AND CABIN WINDOWS

Entry to, and exit from, the airplane is accomplished through either of two entry doors, one on each side of the cabin, at the front seat positions (Refer to Section 6 for cabin and cabin door dimensions). The doors incorporate a recessed exterior door handle, a conventional interior door handle, a key operated door lock (left door only), a door stop mechanism, and openable windows in both the left and right doors.

NOTE

The door latch design on this model requires that the outside door handle on the pilot and front passenger doors be extended out whenever the doors are open. When closing the door, do not attempt to push the door handle in until the door is fully shut.

To open the doors from outside the airplane, utilize the recessed door handle near the aft edge of either door by grasping the forward edge of the handle and pulling outboard. To close or open the doors from inside the airplane, use the combination door handle and arm rest. The inside door handle has three positions and a placard at its base which reads OPEN, CLOSE, and LOCK. The handle is spring loaded to the CLOSE (up) position. When the door has been pulled shut and latched, lock it by rotating the door handle forward to the LOCK position (flush with the arm rest). When the handle is rotated to the LOCK position, an over center action will hold it in that position. Both cabin doors should be locked prior to flight, and should not be opened intentionally during flight.

NOTE

Accidental opening of a cabin door in flight due to improper closing does not constitute a need to land the airplane. The best procedure is to set up the airplane in a trimmed condition at approximately 80 KIAS, momentarily shove the door outward slightly, and forcefully close and lock the door.

(Continued Next Page)

ENTRANCE DOORS AND CABIN WINDOWS

(Continued)

Exit from the airplane is accomplished by rotating the door handle from the LOCK position, past the CLOSE position, aft to the OPEN position and pushing the door open. To lock the airplane, lock the right cabin door with the inside handle, close the left cabin door, and using the ignition key, lock the door.

The left and right cabin doors are equipped with openable windows which are held in the closed position by a detent equipped latch on the lower edge of the window frame. To open the windows, rotate the latch upward. Each window is equipped with a spring-loaded retaining arm which will help rotate the window outward, and hold it there. If required, either window may be opened at any speed up to 175 KIAS. The rear side windows and rear windows are of the fixed type and cannot be opened.

CONTROL LOCKS

A control lock is provided to lock the aileron and elevator control surfaces to prevent damage to these systems by wind buffeting while the airplane is parked. The lock consists of a shaped steel rod and flag. The flag identifies the control lock and cautions about its removal before starting the engine. To install the control lock, align the hole in the side of the pilot's control wheel shaft with the hole in the side of the shaft collar on the instrument panel and insert the rod into the aligned holes. Installation of the lock will secure the ailerons in a neutral position and the elevators in a slightly trailing edge down position. Proper installation of the lock will place the flag over the ignition switch. In areas where high or gusty winds occur, a control surface lock should be installed over the vertical stabilizer and rudder. The control lock and any other type of locking device should be removed prior to starting the engine.

ENGINE

The airplane is powered by a direct drive, horizontally opposed, six cylinder, overhead valve, air cooled, fuel injected engine with a wet sump lubrication system. The engine is a Lycoming Model IO-540-AB1A5 rated at 230 horsepower at 2400 RPM. Major accessories include a propeller governor, starter and belt driven alternator mounted on the front of the engine, dual magnetos, vacuum pump, engine driven fuel pump, and a full flow oil filter mounted on the rear of the engine accessory case.

ENGINE CONTROLS

Engine manifold pressure is set using the throttle control. The throttle control is a smooth black knob located at the center of the instrument panel below the standby instruments. The throttle control is configured so that the throttle is open in the forward position and closed in the full aft position. A friction lock, located at the base of the throttle, is operated by rotating the lock clockwise to increase friction or counterclockwise to decrease friction.

Engine speed is controlled by the propeller control. The propeller control is a fluted blue knob located immediately to the right of the throttle control. This system is described under Propeller in this section.

Engine fuel mixture is controlled by the mixture control. The mixture control is a red knob, with raised points around the circumference, located immediately to the right of the propeller control and is equipped with a lock button in the end of the knob. The rich position is full forward, and full aft is the idle cutoff position. For small adjustments, the control may be moved forward by rotating the knob clockwise, and aft by rotating the knob counterclockwise. For rapid or large adjustments, the knob may be moved forward or aft by depressing the lock button in the end of the control, and then positioning the control as desired.

(Continued Next Page)

ENGINE (Continued)

ENGINE INSTRUMENTS

The G1000 Engine Indication System provides graphical indicators and numeric values for engine, fuel, and electrical system parameters to the pilot. The EIS is shown in a vertical strip on the left side of the PFD during engine starts and on the MFD during normal operation. If either the MFD or PFD fails during flight, the EIS is shown on the remaining display.

The EIS consists of three pages that are selected using the ENGINE softkey. The ENGINE page provides indicators for Manifold Pressure (MAN IN), Tachometer (RPM), Fuel Flow (FFLOW GPH), Oil Pressure (OIL PRES), Oil Temperature (OIL TEMP), Cylinder Head Temperature (CHT), Exhaust Gas Temperature (EGT), Fuel Quantity (FUEL QTY GAL), Electrical Bus Voltages (VOLTS), and Battery Currents (AMPS). When the ENGINE softkey is pressed, the LEAN and SYSTEM softkeys appear adjacent to the ENGINE softkey. The LEAN page provides simultaneous indicators for Exhaust Gas Temperature (EGT °F) and Cylinder Head Temperature (CHT °F) on all cylinders to be used for adjusting, or leaning, the fuel/air mixture along with an indicator for FUEL QTY GAL. The SYSTEM page provides numerical values for parameters on the ENGINE page that are shown as indicators only. The SYSTEM page also provides an indicator for vacuum (VAC) and a digital value for Engine Hours (ENG HRS), Fuel Used (GAL USED) and Fuel Remaining (GAL REM).

The engine and airframe unit, located forward of the instrument panel, receives signals from the engine/system sensors for the parameters that are being monitored. The engine and airframe unit provides data to the EIS, which displays the data for the ENGINE page described on the following pages.

(Continued Next Page)

ENGINE (Continued)

ENGINE INSTRUMENTS (Continued)

MANIFOLD PRESSURE

Manifold pressure is shown by the MAN IN indicator at the top of all EIS pages. The manifold pressure indicator uses a circular scale and moving pointer with a digital value. The pointer moves through a range of 10 to 35 in.hg. The digital manifold pressure value is shown in white numerals below the pointer.

Colored arcs on the manifold pressure indicator show different operating ranges. The normal operating range is from 15 to 23 in.hg. and indicated by the green arc. The acceptable operating range is indicated with a white arc from 10 to 15 in.hg. and 23 to 35 in.hg.

An absolute pressure transducer, located between the firewall and the instrument panel, provides a signal to the engine and airframe unit which processes and outputs the data to the EIS. A red X through the manifold pressure display shows that the indicating system is inoperative.

(Continued Next Page)

ENGINE (Continued)

ENGINE INSTRUMENTS (Continued)

RPM (TACHOMETER)

Engine speed is shown by the RPM indicator, found on all EIS pages below the manifold pressure indicator. The tachometer indicator uses a circular scale with moving pointer and a digital value. The pointer moves through a range from 0 to 2700 RPM. The numerical RPM value is displayed in increments of 10 RPM in white numerals below the pointer.

The normal engine speed operating limit (red line) is 2400 RPM. When engine speed is 2472 RPM or more, the pointer, digital value, and label (RPM) turn red to show engine speed is more than the limit. The digital value and label (RPM) will flash. The engine speed (tachometer) is displayed in the same configuration and location on the LEAN and SYSTEM pages. If engine speed becomes 2472 RPM or more, while on the LEAN or SYSTEM page, the display will return to the ENGINE page.

A speed sensor, mounted on the engine tachometer drive accessory pad, provides a digital signal to the engine and airframe unit which processes and outputs the RPM data to the EIS. A red X through the RPM indicator shows the indicating system is inoperative.

FUEL FLOW

Fuel flow is shown on the ENGINE page by the FFLOW GPH horizontal indicator. The indicator range is from 0 to 22 gallons per hour (GPH) with 2 GPH graduations, with a green band from 0 to 15 GPH. A white pointer shows the measured fuel flow.

A digital value for FFLOW GPH is included on both the EIS LEAN and SYSTEM pages.

The fuel flow transducer is located in the engine fuel injection system between the fuel/air control unit (servo) and the fuel distribution manifold (flow divider). The transducer provides a signal to the engine display that is processed and shown as fuel flow (FFLOW) on the EIS pages. A red X through the indicator means the indicating system is inoperative.

(Continued Next Page)

ENGINE (Continued)

ENGINE INSTRUMENTS (Continued)

OIL PRESSURE

Engine oil pressure is shown on the ENGINE page by the OIL PRES horizontal indicator. The indicator range is 0 to 120 PSI with a red band from 0 to 20 PSI, a green band from 50 to 90 PSI (normal operating range) and a red band from 115 to 120 PSI. A white pointer indicates actual oil pressure. Oil pressure is shown numerically on the SYSTEM page.

When oil pressure is 0 to 20 PSI or 115 to 120 PSI, the pointer, digital value, and label (OIL PRES) will change to red to show that oil pressure is outside normal limits. If oil pressure exceeds either the upper or lower limit while on the LEAN or SYSTEM page, the EIS will return to the ENGINE page.

When the engine speed (RPM) is in the green arc and the oil temperature is in the green band, the oil pressure should be in the green band. If oil pressure is below the green band or above the green band, adjust the engine speed to maintain adequate oil pressure. When engine speed is at idle or near idle, the oil pressure indication must be above the lower red band. With the engine at normal operating oil temperature, and engine speed at or close to idle, oil pressure below the green band, but above the lower red band, is acceptable.

In cold weather, the oil pressure will initially be high (close to the upper red band when the engine is started). As the engine and oil warm up, the oil pressure will come down into the green band range.

The oil pressure transducer, connected to the engine forward oil pressure port, provides a signal to the engine display that is processed and shown as oil pressure. A separate low oil pressure switch causes an OIL PRESSURE annunciation on the PFD when oil pressure is 0 to 20 PSI. A red X through the oil pressure indicator means that the indicating system is inoperative.

(Continued Next Page)

ENGINE (Continued)

ENGINE INSTRUMENTS (Continued)

OIL TEMPERATURE

Engine oil temperature is shown on the ENGINE page by the OIL TEMP horizontal indicator. The indicator range is from 75°F to 250°F with a green band (normal operating range) from 100°F to 245°F and a red band from 245°F to 250°F. A white pointer indicates actual oil temperature. Oil temperature is displayed numerically on the SYSTEM page.

When oil temperature is in the red band, 245°F to 250°F, the pointer and OIL TEMP turn red and flash to show oil temperature is higher than the limit. If oil temperature becomes hotter than 245°F while on the LEAN or SYSTEM page, the display will default to the ENGINE page.

The oil temperature sensor is installed in the engine oil filter adapter and provides a signal to the engine display that is processed and shown as oil temperature. A red X through the indicator shows that the indicating system is inoperative.

(Continued Next Page)

ENGINE (Continued)

ENGINE INSTRUMENTS (Continued)

CYLINDER HEAD TEMPERATURE

Cylinder head temperature is shown on the ENGINE page on the CHT horizontal indicator. The gage range is from 100°F to 500°F, with a green band from 200°F to 500°F and red line at 500°F. The white pointer indicates relative CHT while the number inside of the pointer identifies the hottest cylinder head. If a CHT probe or wire failure occurs for the hottest CHT, the next hottest CHT will be displayed.

When the CHT is 500°F or hotter, the pointer will change to red and the CHT label will change to red and flash to show that the CHT is greater than the limit. If CHT becomes hotter than 500°F while on the LEAN or SYSTEM page, the display will default to the ENGINE page.

The CHT for all six cylinders are shown on the LEAN page. The cylinder with the hottest CHT is indicated by a cyan bar graph. The CHT for cylinder number three has been demonstrated to be the most critical, and operation with CHT 3 inoperative is not allowed. The LEAN page will show a red X over any cylinder that has a probe or wiring failure.

A thermocouple is installed in each cylinder head and provides a signal to the engine display that is processed and shown as CHT on the EIS LEAN page.

(Continued Next Page)

ENGINE (Continued)

ENGINE INSTRUMENTS (Continued)

EXHAUST GAS TEMPERATURE

Exhaust gas temperature is shown by the EGT horizontal indicator on the EIS. The indicator range is from 1100°F to 1500°F with graduations every 50°F. The white pointer indicates relative EGT with the number of the hottest cylinder displayed inside the pointer. If a cylinder EGT probe or wiring failure occurs for the hottest EGT, the next hottest EGT will be displayed.

The EGT for all six cylinders is shown on the LEAN page of the EIS. The hottest cylinder is indicated by the cyan bar graph. The EGT for a particular cylinder may be shown by using the CYL SLCT softkey to select the desired cylinder. Automatic indication of the hottest cylinder will resume a short time after the CYL SLCT is last selected. The LEAN page will show a red X over a cylinder that has a probe or wiring failure.

A thermocouple is installed in the exhaust pipe of each cylinder which measures EGT and provides a signal to the engine display that is processed and shown as EGT on the EIS LEAN page.

(Continued Next Page)

ENGINE (Continued)

NEW ENGINE BREAK-IN AND OPERATION

The engine run-in was accomplished at the factory and is ready for the full range of use. It is suggested that cruising be accomplished at 75% power as much as practicable until a total of 50 hours has accumulated or oil consumption has stabilized. This will ensure proper seating of the piston rings.

ENGINE LUBRICATION SYSTEM

The engine utilizes a full pressure, wet sump type lubrication system with aviation grade oil as the lubricant. The capacity of the engine sump, located on the bottom of the engine, is nine quarts with one additional quart contained in the engine oil filter. Oil is drawn from the sump through a filter screen on the end of a pickup tube to the engine driven oil pump. Oil from the pump passes through a full-flow oil filter, a pressure relief valve at the rear of the right oil gallery, and a thermostatically controlled remote oil cooler. Oil from the remote cooler is then circulated to the left oil gallery and propeller governor. The engine parts are then lubricated by oil from the galleries. After lubricating the engine, the oil returns to the sump by gravity. The filter adapter in the full-flow filter is equipped with a bypass valve which will cause lubricating oil to bypass the filter in the event the filter becomes plugged, or the oil temperature is extremely cold.

An oil dipstick/filler tube is located on the upper left side of the engine case. The dipstick and oil filler tube are accessed through a door located on the left center portion of the upper engine cowling. The engine should not be operated on less than four quarts of oil. To minimize loss of oil through the breather, fill to eight quarts for normal flights of less than three hours. For extended flight, fill to nine quarts (dipstick indication only). For engine oil grade and specifications, refer to Section 8 of this POH.

(Continued Next Page)

ENGINE (Continued)

IGNITION AND STARTER SYSTEM

Engine ignition is provided by two engine driven magnetos, and two spark plugs in each cylinder. The left magneto fires the upper left and lower right spark plugs, and the right magneto fires the lower left and upper right spark plugs. Normal operation is conducted with both magnetos due to the more complete burning of the fuel/air mixture with dual ignition.

Ignition and starter operation is controlled by a rotary-type switch located on the left switch and control panel. The switch is labeled clockwise, OFF, R, L, BOTH, and START. The engine should be operated on both magnetos (BOTH position) except for magneto checks. The R and L positions are for checking purposes and emergency use only. When the switch is rotated to the START position, (with the MASTER switch in the ON position), the starter contactor is closed and the starter, now energized, will crank the engine. When the switch is released, it will automatically return to the BOTH position.

AIR INDUCTION SYSTEM

The engine air induction system receives ram air through an intake on the lower front portion of the engine cowling. The intake is covered by an air filter which removes dust and other foreign matter from the induction air. Airflow passing through the filter enters an air box, which is equipped with a spring-loaded alternate air door. If the air induction filter should become blocked, suction created by the engine will open the door and draw unfiltered air from inside the lower cowl area. An open alternate air door will result in an approximate 10% power loss at full throttle. After passing through the air box, induction air enters a fuel/air control unit under the engine, and is then ducted to the engine cylinders through intake manifold tubes.

(Continued Next Page)

ENGINE (Continued)

EXHAUST SYSTEM

Exhaust gas from each cylinder passes through a riser or exhaust collector assembly (on the left or right side below the engine) to a muffler and overboard through a single tailpipe. Outside air is supplied to a shroud constructed around the outside of each muffler to form a heating chamber. The air heated by the shroud is then supplied to the cabin.

FUEL INJECTION SYSTEM

The engine is equipped with a fuel injection system. The system is comprised of an engine driven fuel pump, fuel/air control unit, fuel manifold, fuel flow indicator, and air-bleed type injector nozzles.

Fuel is delivered by the engine driven fuel pump to the fuel/air control unit. The fuel/air control unit correctly proportions the fuel flow to the induction air flow. After passing through the control unit, induction air is delivered to the cylinders through the intake manifold tubes and metered fuel is delivered to a fuel manifold (flow divider). The fuel manifold, through spring tension on a diaphragm and valve, evenly distributes the fuel to an air-bleed type injector nozzle in the intake valve chamber of each cylinder. A turbine-type fuel flow transducer mounted between the fuel/air control unit and the fuel distribution unit produces a digital signal that displays fuel flow on the EIS pages.

(Continued Next Page)

ENGINE (Continued)

COOLING SYSTEM

Ram air for engine cooling enters through two intake openings in the front of the engine cowling. The cooling air is directed from above the engine, around the cylinders and other areas of the engine by baffling, and then exits through cowl flaps on the lower aft edge of the cowling. The cowl flaps are mechanically operated from the cabin by means of the cowl flap control lever located on the right side of the control pedestal and is labeled OPEN, COWL FLAPS, CLOSED. Any time the control lever is repositioned, it must first be moved to the right to clear the detent.

Before starting the engine, before takeoff and during high power operation, the cowl flap control lever should be placed in the OPEN position for maximum cooling. This is accomplished by moving the control lever to the right to clear a detent, then moving the control lever up to the OPEN position.

While in cruise flight, cowl flaps should be closed unless hot day conditions require them to be adjusted to keep the CHT/CT at approximately two-thirds of the normal operating range (green band).

During extended descents, it may be necessary to completely close the cowl flaps by pushing the cowl flap control lever down to the CLOSED position.

A winterization kit is available for the airplane. Refer to Section 9, Supplement 5 for description and operating information.

PROPELLER

The airplane has an all metal, three-bladed, constant speed, governor regulated propeller. A setting introduced into the governor with the propeller control establishes the propeller speed, and thus the engine speed to be maintained. The governor then controls flow of engine oil, boosted to high pressure by the governing pump, to or from a piston in the propeller hub. Oil pressure acting on the piston twists the blades toward high pitch (low RPM). When oil pressure to the piston in the propeller hub is relieved, centrifugal force, assisted by an internal spring, twists the blades toward low pitch (high RPM).

A propeller control knob, located on the lower center instrument panel, is used to set the propeller and control engine RPM as desired for various flight conditions. The control knob is labeled PROPELLER, PUSH INCR RPM. When the control knob is pushed in, blade pitch will decrease, giving a higher RPM. When the control knob is pulled out, the blade pitch increases, thereby decreasing RPM. The propeller control knob is equipped with a vernier feature which allows slow or fine RPM adjustments by rotating the knob clockwise to increase RPM, and counterclockwise to decrease it. To make rapid or large adjustments, depress the button on the end of the control knob and reposition the control as desired.

FUEL SYSTEM

The airplane fuel system (Refer to Figure 7-6) consists of two vented integral fuel tanks (one tank in each wing), two fuel manifolds (one in each aft doorpost), a dual stack, four-position selector valve, an electrically-driven auxiliary fuel pump, and a fuel strainer. The engine-mounted portion of the system consists of the engine driven fuel pump, a fuel/air control unit, fuel flow transducer, a fuel distribution valve (flow divider) and fuel injection nozzles.

The fuel system also incorporates a fuel return system that returns fuel from the top of the fuel servo back to each integral wing tank. The system includes a flexible fuel hose assembly between the servo and the firewall. Aluminum fuel lines return the fuel to the top portion of the selector valve and then to the airplane's integral tanks. One drain is added to properly drain the fuel return system.

WARNING

UNUSABLE FUEL LEVELS FOR THIS AIRPLANE WERE DETERMINED IN ACCORDANCE WITH FEDERAL AVIATION REGULATIONS. FAILURE TO OPERATE THE AIRPLANE IN COMPLIANCE WITH FUEL LIMITATIONS SPECIFIED IN SECTION 2 MAY FURTHER REDUCE THE AMOUNT OF FUEL AVAILABLE IN FLIGHT.

(Continued Next Page)

FUEL SYSTEM (Continued)

FUEL QUANTITY DATA IN U.S. GALLONS

FUEL TANKS	FUEL LEVEL (QUANTITY EACH TANK)	TOTAL FUEL	TOTAL UNUSABLE	TOTAL USABLE ALL FLIGHT CONDITIONS
Two	Full (46.0)	92.0	5.0	87.0
Two	Reduced (39.5)	79.0	5.0	74.0
Two	Reduced (34.5)	69.0	5.0	64.0

Figure 7-5*

FUEL DISTRIBUTION

Fuel flows by gravity from the two wing tanks through the fuel manifold (aft pickup only), and to a four position selector valve. From the selector valve, fuel flows through the auxiliary fuel pump, the fuel strainer, and to the engine driven fuel pump. A portion of the fuel (approximately 7 GPH) is returned to the wing tank currently selected through the use of the fuel return system. From the engine driven fuel pump, fuel is delivered to the fuel/air control unit on the bottom of the engine. The fuel/air control unit (fuel servo) meters fuel flow in proportion to induction air flow. After passing through the control unit, metered fuel goes to a fuel distribution valve (flow divider) located on the bottom of the engine. From the fuel distribution valve, individual fuel lines are routed to air bleed type injector nozzles located in the intake chamber of each cylinder.

FUEL INDICATING SYSTEM

Fuel quantity is measured by two fuel quantity sensors, one in each fuel tank, and is displayed on the EIS pages. The indicators are marked in gallons of fuel (GAL). An empty tank is displayed on the fuel quantity indicator (FUEL QTY GAL) as a red line on the far left of the indicator scale, and the number 0. When an indicator shows an empty tank, approximately 2.5 gallons of unusable fuel remain in the tank. The indicators should not be relied upon for accurate readings during skids, slips or unusual attitudes.

(Continued Next Page)

FUEL SYSTEM (Continued)

FUEL INDICATING SYSTEM (Continued)

The fuel quantity indicator shows the fuel available in the tank up to the limit of the sensor measurement range. At this level, additional fuel may be added to completely fill the tank, but no additional movement of the indicator will result. The limit for sensor measurement range is approximately 35 gallons and is indicated by the maximum limit of the green band. When the fuel level decreases below the maximum limit of the fuel sensor, the fuel quantity indicator will display fuel quantity measured in each tank. A visual check of each wing tank fuel level must be performed prior to each flight. Compare the visual fuel level and indicated fuel quantity to accurately estimate usable fuel.

The fuel quantity indicators detect low fuel conditions and incorrect sensor outputs. When fuel quantity is less than 8 gallons indicated (and remains less than this level for more than 60 seconds), LOW FUEL L (left) and/or LOW FUEL R (right) will be displayed in amber on the PFD and a tone will sound. The fuel quantity indicator pointer(s) and indicator label will change from white to steady amber. When fuel quantity reaches the calibrated usable fuel empty level, the LOW FUEL L and/or LOW FUEL R remain amber and the indicator pointer(s) and label change to flashing red.

NOTE

Takeoff is not recommended if both fuel quantity indicator pointers are in the yellow band range and/or amber LOW FUEL L or LOW FUEL R annunciator is displayed on the PFD.

In addition to low fuel annunciation, the warning logic is designed to report failures with each sensor. If the system detects a failure, the affected fuel indicator will display a red X. A red X through the top part of the indicator indicates a failure associated with the left fuel tank. A red X through the bottom part of the indicator indicates a failure associated with the right fuel tank.

(Continued Next Page)

FUEL SYSTEM (Continued)

FUEL INDICATING SYSTEM (Continued)

Fuel flow is measured by use of a turbine type transducer mounted on the centerline of the engine between the fuel/air control unit and the fuel distribution unit. This flow meter produces a signal that is displayed as the rate of fuel flow on the FFLOW GPH indicator on the EIS pages. FFLOW GPH is shown as either a horizontal analog indicator or a digital value, depending on the active EIS page.

FUEL CALCULATIONS

NOTE

Fuel calculations do not use the airplane's fuel quantity indicators and are calculated from the last time the fuel was reset.

For fuel consumption information, a fuel used totalizer function is provided on the EIS SYSTEM page as GAL USED. This digital indicator shows total fuel used since last reset of the totalizer. To reset the GAL USED, the EIS SYSTEM page must be active and the RST USED softkey must be selected. GAL USED is calculated after reset using information from the fuel flow transducer signal.

For fuel remaining information, a count down fuel totalizer function is provided on the EIS System page as GAL REM. This digital indicator shows calculated fuel remaining since last GAL REM pilot adjustment. To adjust GAL REM, the EIS SYSTEM page must be active and the GAL REM softkey must be selected followed by the appropriate quantity adjustment softkeys. Refer to the Garmin G1000 CRG for details for resetting and adjusting fuel calculations. GAL REM is calculated after pilot adjustment using information from the fuel flow transducer signal.

NOTE

GAL USED and GAL REM provide no indication of the actual amount of fuel remaining in each tank and should only be used in conjunction with other fuel management procedures to estimate total fuel remaining.

(Continued Next Page)

FUEL SYSTEM (Continued)

B3776

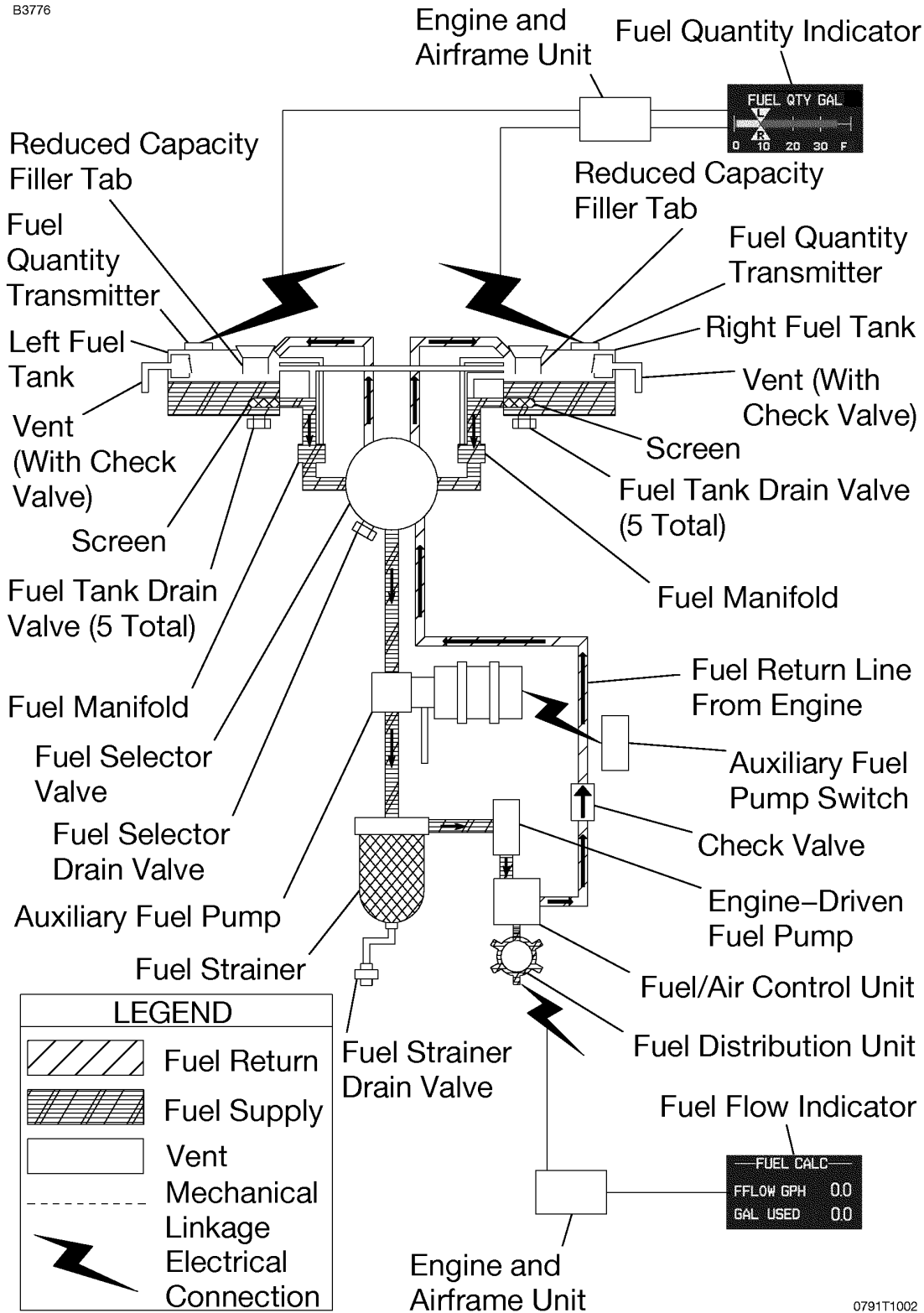

0791T1002

Figure 7-6*

FUEL SYSTEM (Continued)

AUXILIARY FUEL PUMP OPERATION

The auxiliary fuel pump is used primarily for priming the engine before starting. Priming is accomplished through the fuel injection system. The engine may be flooded if the auxiliary FUEL PUMP switch is accidentally placed in the ON position for prolonged periods, with MASTER Switch ON and mixture rich, with the engine stopped.

The auxiliary fuel pump is also used for vapor suppression in hot weather. Normally, momentary use will be sufficient for vapor suppression; however, continuous operation is permissible if required. Turning on the auxiliary fuel pump with a normally operating engine driven fuel pump will result in only a very minor enrichment of the mixture.

It is not necessary to operate the auxiliary fuel pump during normal takeoff and landing, since gravity and the engine driven fuel pump will supply adequate fuel flow. In the event of failure of the engine driven fuel pump, use of the auxiliary fuel pump will provide sufficient fuel to maintain flight at maximum continuous power.

Under hot day, high altitude conditions, or conditions during a climb that are conducive to fuel vapor formation, it may be necessary to utilize the auxiliary fuel pump to attain or stabilize the fuel flow required for the type of climb being performed. In this case, turn the auxiliary fuel pump on, and adjust the mixture to the desired fuel flow. If fluctuating fuel flow (greater than 1 GPH) is observed during climb or cruise at high altitudes on hot days, place the auxiliary fuel pump switch in the ON position to clear the fuel system of vapor. The auxiliary fuel pump may be operated continuously in cruise.

(Continued Next Page)

FUEL SYSTEM (Continued)

FUEL RETURN SYSTEM

A fuel return system was incorporated to improve engine operation during extended idle operation in hot weather environments. The major components of the system include an orifice fitting located in the top of the fuel servo, a dual stack fuel selector and a drain valve assembly. The system is designed to return fuel/vapor back to the main fuel tanks at approximately 7 GPH. The dual stack fuel selector ensures that fuel/vapor returns only to the fuel tank that is selected as the feed tank. For example, if the fuel selector is positioned to use fuel from the left fuel tank, the fuel return system is returning fuel/vapor to the left fuel tank only.

FUEL VENTING

Fuel system venting is essential to system operation. Complete blockage of the fuel venting system will result in decreasing fuel flow and eventual engine stoppage. The fuel venting system consists of an interconnecting vent line between the fuel tanks and check valve equipped overboard vents in each fuel tank. The overboard vents protrude from the bottom surface of the wings behind the wing struts, slightly below the upper attach points of the struts. The fuel filler caps are vacuum vented; the fuel filler cap vents will open and allow air to enter the fuel tanks in case the overboard vents become blocked.

REDUCED TANK CAPACITY

The airplane may be serviced to a reduced capacity to permit heavier cabin loadings. This is accomplished by filling each tank to the bottom edge of the fuel filler indicator tab, thus giving a reduced fuel load of 32.0 gallons usable in each tank or to the line of holes located inside the filler indicator tab, thus giving a reduced fuel load of 37.0 gallons usable in each tank.

(Continued Next Page)

FUEL SYSTEM (Continued)

FUEL SELECTOR VALVE

The fuel selector is a four-position selector valve, labeled BOTH, RIGHT, LEFT and OFF. The selector handle must be pushed down before it can be rotated from RIGHT or LEFT to OFF. The top portion of the valve is the return portion of the valve, while the bottom portion of the valve is the supply portion. Each side is isolated from the other.

The fuel selector valve should be in the BOTH position for takeoff, climb, landing, and maneuvers that involve prolonged slips or skids of more than 30 seconds. Operation on either LEFT or RIGHT fuel tank is reserved for level cruising flight only.

NOTE

- When the fuel selector valve is placed in the BOTH position, while in cruise flight, unequal fuel flow from each tank may occur if the wings are not maintained exactly level. Unequal fuel flow can be detected by one fuel tank indicating more fuel than the other on the L FUEL and R FUEL indicators. The resulting fuel imbalance can be corrected by turning the fuel selector valve to the fuel tank indicating the highest fuel quantity. Once the L FUEL and R FUEL indicators have equalized, position the fuel selector valve to the BOTH position.
- It is not practical to measure the time required to consume all of the fuel in one tank, and, after switching to the opposite tank, expect an equal duration from the remaining fuel. The airspace in both fuel tanks is interconnected by a vent line and, therefore, some sloshing of fuel between tanks can be expected when the tanks are nearly full and the wings are not level.
- When the fuel tanks are 1/4 tank or less, prolonged uncoordinated flight, such as slips or skids, can uncover the fuel tank outlets causing fuel starvation and engine stoppage. Therefore, if operating with one fuel tank dry or operating on either LEFT or RIGHT tank with 1/4 tank or less, do not allow the airplane to remain in uncoordinated flight for periods in excess of 30 seconds.

(Continued Next Page)

FUEL SYSTEM (Continued)

FUEL DRAIN VALVES

The fuel system is equipped with drain valves to provide a means for the examination of fuel in the system for contamination and grade. The system should be examined before each flight and after each refueling, by using the sampler cup provided to drain fuel from each wing tank sump, the fuel return side sump, the fuel selector drain and the fuel strainer sump. If any evidence of fuel contamination is found, it must be eliminated in accordance with the preflight inspection checklist and the discussion in Section 8. If takeoff weight limitations for the next flight permit, the fuel tanks should be filled after each flight to prevent condensation.

BRAKE SYSTEM

The airplane has a single-disc, hydraulically-actuated brake on each main landing gear wheel. Each brake is connected, by a hydraulic line, to a master cylinder attached to each of the pilot's rudder pedals. The brakes are operated by applying pressure to the top of either the left (pilot's) or right (copilot's) set of rudder pedals, which are interconnected. When the airplane is parked, both main wheel brakes may be set by utilizing the parking brake which is operated by a handle under the left side of the instrument panel. To apply the parking brake, set the brakes with the rudder pedals, pull the handle aft, and rotate it 90° down.

For maximum brake life, keep the brake system properly maintained, and minimize brake usage during taxi operations and landings.

Some of the symptoms of impending brake failure are: gradual decrease in braking action after brake application, noisy or dragging brakes, soft or spongy pedals, and excessive travel and weak braking action. If any of these symptoms appear, the brake system is in need of immediate attention. If, during taxi or landing roll, braking action decreases, let up on the pedals and then reapply the brakes with heavy pressure. If the brakes become spongy or pedal travel increases, pumping the pedals should build braking pressure. If one brake becomes weak or fails, use the other brake sparingly while using opposite rudder, as required, to offset the good brake

ELECTRICAL SYSTEM

The airplane is equipped with a 28-volt direct current (DC) electrical system (Refer to Figure 7-7). A belt-driven 60 ampere or optional 95 ampere alternator powers the system. A 24-volt main storage battery is located in the tailcone of the airplane. The alternator and main battery are controlled through the MASTER switch found near the top of the pilot's switch panel.

Power is supplied to most electrical circuits through two primary buses (ELECTRICAL BUS 1 and ELECTRICAL BUS 2), with an essential bus and a crossfeed bus connected between the two primary buses to support essential equipment.

The system is equipped with a secondary or standby battery located between the firewall and the instrument panel. The STBY BATT switch controls power to or from the standby battery. The standby battery is available to supply power to the essential bus in the event that alternator and main battery power sources have both failed.

The primary buses are supplied with power whenever the MASTER switch is turned on, and are not affected by starter or external power usage. Each primary bus is also connected to an avionics bus through a circuit breaker and the AVIONICS BUS 1 and BUS 2 switches. Each avionics bus is powered when the MASTER switch and the corresponding AVIONICS switch are in the ON position.

CAUTION

BOTH BUS 1 AND BUS 2 AVIONICS SWITCHES SHOULD BE TURNED OFF TO PREVENT ANY HARMFUL TRANSIENT VOLTAGE FROM DAMAGING THE AVIONICS EQUIPMENT PRIOR TO TURNING THE MASTER SWITCH ON OR OFF, STARTING THE ENGINE OR APPLYING AN EXTERNAL POWER SOURCE.

The airplane includes a power distribution module, located on the left forward side of the firewall, to house all the relays used in the airplane electrical system. The Alternator Control Unit (ACU), main battery current sensor, and the external power connector are also housed within the module.

(Continued Next Page)

ELECTRICAL SYSTEM (Continued)

B1524

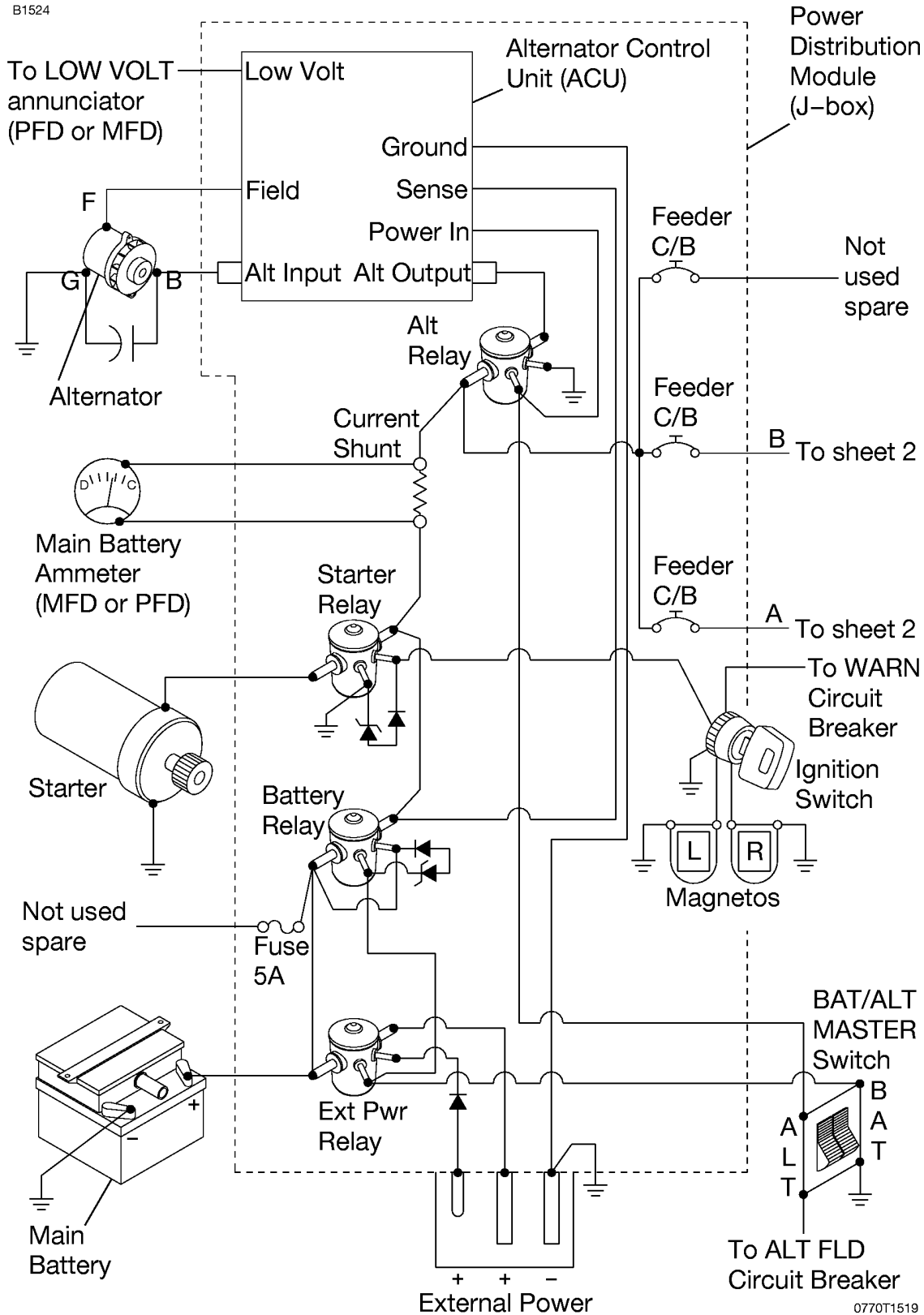

0770T1519

Figure 7-7 (Sheet 1 of 3)

ELECTRICAL SYSTEM (Continued)

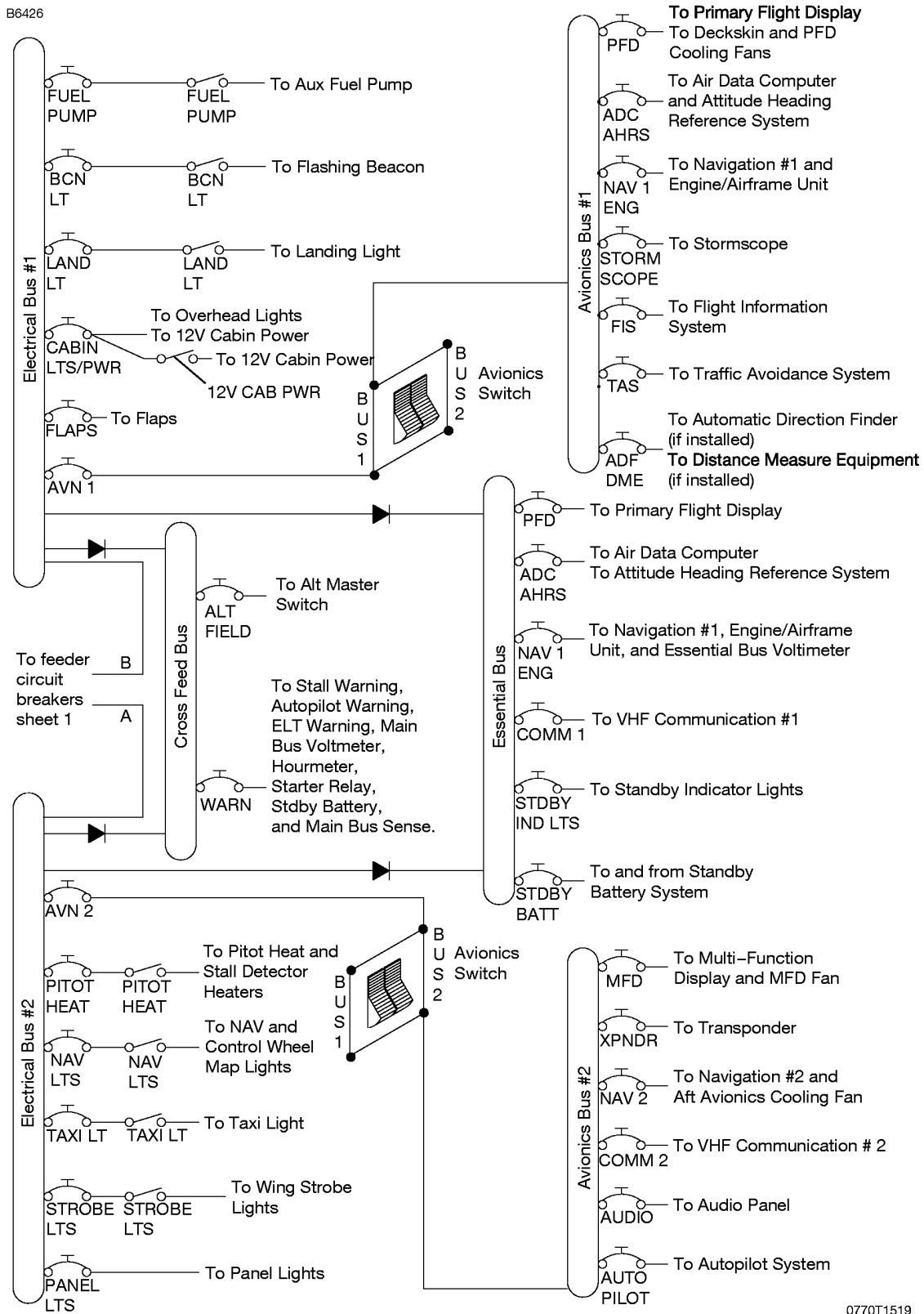

0770T1519

Figure 7-7 (Sheet 2)

ELECTRICAL SYSTEM (Continued)

B3766

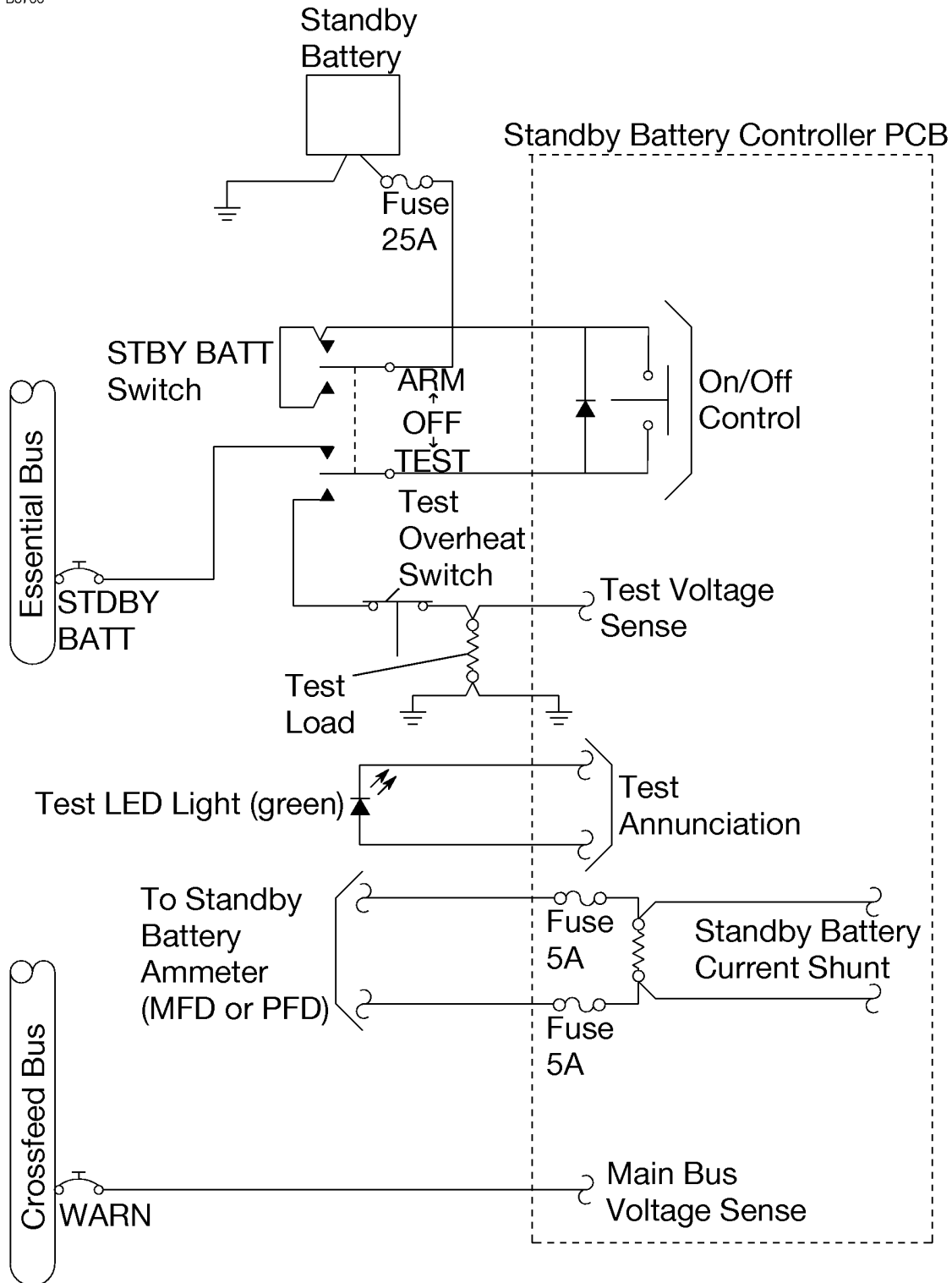

0770T1519

Figure 7-7 (Sheet 3)

ELECTRICAL SYSTEM (Continued)

G1000 ANNUNCIATOR PANEL

All system alerts, cautions and warnings are shown on the right side of the PFD screen adjacent to the vertical speed indicator. The following annunciations are supported:

■ OIL PRESSURE	LOW VACUUM
■ LOW FUEL L	LOW FUEL R
■ LOW VOLTS	HIGH VOLTS
■ STBY BATT	CO LVL HIGH

Refer to the Garmin G1000 CRG Appendix A for more information on system annunciations.

MASTER SWITCH

The MASTER switch is a two-pole, rocker-type switch. The BAT side of the switch controls the main battery electrical power to the airplane. The ALT side of the switch controls the alternator system.

In normal operation, both sides of the switch (ALT and BAT) are ON simultaneously; however, the BAT side of the switch may be selected separately as necessary. The ALT side of the switch can not be set to ON without the BAT side of the switch also being set to ON.

If the alternator system fails, the MASTER switch may be set in the OFF position to preserve main battery capacity for later in the flight. With the MASTER switch OFF and the STBY BATT switch in the ARM position, the standby battery will power the essential bus for a limited time. Time remaining may be estimated by monitoring essential bus voltage. At 20 Volts, the standby battery has little or no capacity remaining.

(Continued Next Page)

ELECTRICAL SYSTEM (Continued)

STANDBY BATTERY SWITCH

The STBY BATT master switch is a three position (ARM-OFF-TEST) switch that tests and controls the standby battery system. The energy level of the battery shall be checked before starting the engine (Refer to Section 4) by placing the switch in the momentary TEST position and observing the correct illumination of the TEST lamp found to the right of the switch. Energy level tests after starting engine are not recommended.

Placing the switch in the ARM position during the engine start cycle allows the standby battery to help regulate and filter essential bus voltage during the start cycle. The switch is set to the ARM position during normal flight operation to allow the standby battery to charge and to be ready to power the essential bus in the event of alternator and main battery failure. Placing the switch in the OFF position disconnects the standby battery from the essential bus. Operation with the STBY BATT switch in the OFF position prevents the standby battery from charging and from automatically providing power should an electrical system failure occur.

AVIONICS SWITCH

The AVIONICS switch is a two-pole rocker-type switch that controls electrical power to AVIONICS BUS 1 and BUS 2. Placing either side of the rocker switch in the ON position supplies power to the corresponding avionics bus. Both sides of the AVIONICS switch should be placed in the OFF position before turning the MASTER switch ON or OFF, starting the engine, or applying an external power source.

(Continued Next Page)

ELECTRICAL SYSTEM (Continued)

ELECTRICAL SYSTEM MONITORING AND ANNUNCIATIONS

BUS VOLTAGE (VOLTMETERS)

Voltage indication (VOLTS) for the main and essential buses is provided at the bottom of the EIS bar (along the left margin of the MFD or PFD), labeled M BUS E. Main bus voltage is shown numerically below the M. Essential bus voltage is displayed numerically below the E. The main bus voltage is measured at the WARN circuit breaker on the crossfeed bus. The essential bus voltage is measured at the NAV1 ENG circuit breaker on the essential bus.

Normal bus voltages with the alternator operating shall be about 28.0 volts. When the voltage for either main or essential buses is above 32.0 volts, the numerical value and VOLTS text turns red. This warning indication, along with the HIGH VOLTS annunciation, is an indication that the alternator is supplying too high of a voltage. The ALT MASTER Switch should immediately be positioned to OFF (Refer to Section 3, Emergency Procedures, HIGH VOLTS ANNUNCIATOR COMES ON).

When the voltage for either main or essential buses is below 24.5 volts, the numeric value and VOLTS text turns red. This warning indication, along with the LOW VOLTS annunciation, is an indication that the alternator is not supplying all the power that is required by the airplane. Indicated voltages between 24.5 and 28.0 volts may occur during low engine RPM conditions (Refer to note under LOW VOLTAGE ANNUNCIATION).

(Continued Next Page)

ELECTRICAL SYSTEM (Continued)

ELECTRICAL SYSTEM MONITORING AND ANNUNCIATIONS

AMMETERS

Current indication (AMPS) for both the main and standby batteries is provided at the bottom of the EIS bar (along the left margin of the MFD or PFD), labeled M BATT S. Main battery current is numerically displayed below the M. Main battery current greater than -1.5 amps is shown in white. Standby battery current is displayed numerically below the S. A positive current value (shown in white) indicates that the battery is charging. A negative current value (shown in amber) indicates that the battery is discharging. In the event the alternator is not functioning or the electrical load exceeds the output of the alternator, the main battery ammeter indicates the main battery discharge rate.

In the event that standby battery discharge is required, normal steady state discharge should be less than 4 amps. The STBY BATT annunciator will come on when discharge rates are greater than 0.5 amps for more than 10 seconds. After engine start, with the STBY BATT switch in the ARM position, the standby battery ammeter should indicate a charge showing correct charging of the standby battery system.

STANDBY BATTERY ANNUNCIATION

The STBY BATT annunciator will come on when discharge rates are greater than 0.5 amps for more than 10 seconds. This caution annunciation is an indication that the alternator and the main battery are not supplying the power that is required by the essential bus. If the condition causing the caution can not be resolved, flight should be terminated as soon as practicable.

(Continued Next Page)

ELECTRICAL SYSTEM (Continued)

ELECTRICAL SYSTEM MONITORING AND ANNUNCIATIONS (Continued)

LOW VOLTAGE ANNUNCIATION

A signal from the ACU, located inside the power distribution module, provides the trigger for a red LOW VOLTS annunciation shown on the PFD. LOW VOLTS is displayed when the main bus voltage measured in the power distribution module is below 24.5 volts. The LOW VOLTS warning annunciation is an indication that the alternator is not supplying the power that is required by the airplane. If the conditions causing the LOW VOLTS warning can not be resolved, nonessential electrical loads should be eliminated and the flight should be terminated as soon as practicable.

NOTE

During low RPM operation, with a high electrical load on the system, such as during a low RPM taxi, the LOW VOLTS annunciation may come on, the bus voltage values may turn red, and main battery ammeter discharge indications may occur. Under these conditions, increase RPM or decrease electrical loads to reduce demand on the battery.

In the event an overvoltage condition (or other alternator fault) occurs, the ACU will automatically open the ALT FIELD circuit breaker, removing alternator field current and stopping alternator output. The main battery will then supply current to the electrical system as shown by a discharge (negative number) on the M BATT ammeter. The LOW VOLTS annunciator will come on when the system voltage drops below 24.5 volts. Set the ALT FIELD circuit breaker to the ON position (push in) to energize the ACU. If the warning annunciation goes out and the main battery (M BATT) ammeter indicates positive current, normal alternator charging has resumed. If the annunciator comes on again, or the ALT FIELD circuit breaker opens again, an alternator malfunction has occurred. If the circuit breaker opens again, do not SET it to the ON position again. Have a qualified technician determine the cause and correct the malfunction. Turn off nonessential electrical loads and land as soon as practicable.

(Continued Next Page)

ELECTRICAL SYSTEM (Continued)

ELECTRICAL SYSTEM MONITORING AND ANNUNCIATIONS (Continued)

LOW VOLTAGE ANNUNCIATION (Continued)

The ALT FIELD circuit breaker may open on occasion during normal engine starts due to transient voltages. Provided that normal alternator output is resumed after the ALT FIELD circuit breaker is reset, these occurrences are considered nuisance events. If the ALT FIELD circuit breaker opens after reset, do not close again. Repeated occurrences indicate a problem with the electrical system that must be corrected by a qualified maintenance technician before flight.

HIGH VOLTAGE ANNUNCIATION

The HIGH VOLTS annunciator will come on when main or essential bus voltage is above 32.0 volts. This warning annunciation is an indication that the alternator is supplying too high of a voltage. The ALT MASTER switch should immediately be positioned to OFF (Refer to Section 3, Emergency Procedures, HIGH VOLTS ANNUNCIATOR COMES ON).

In the event a HIGH VOLTS condition occurs, the ACU will automatically open the ALT FIELD circuit breaker, removing alternator field current and stopping alternator output. The HIGH VOLTS annunciator is a warning that the ACU automatic alternator shutdown circuit is not operational and an action from the pilot is required to position the ALT MASTER to OFF.

(Continued Next Page)

ELECTRICAL SYSTEM (Continued)

CIRCUIT BREAKERS AND FUSES

Individual system circuit breakers are found on the circuit breaker panel below the pilot's control wheel. All circuit breakers on ESSENTIAL BUS, AVIONICS BUS 1 and AVIONICS BUS 2 are capable of being opened or disengaged from the electrical system by pulling straight out on the outer ring for emergency electrical load management. Using a circuit breaker as a switch is discouraged since the practice will decrease the life of the circuit breaker. All circuit breakers on ELECTRICAL BUS 1, ELECTRICAL BUS 2 and CROSSFEED BUS are not capable of being opened or disengaged.

The power distribution module uses three push-to-reset circuit breakers for the electrical bus feeders. A fast blow automotive type fuse is used at the standby battery. The standby battery current shunt circuit uses two field replaceable fuses located on the standby battery controller printed circuit board.

Most Garmin G1000 equipment has internal non-field replaceable fuses. Equipment must be returned to Garmin by an approved service station for replacement.

(Continued Next Page)

ELECTRICAL SYSTEM (Continued)

EXTERNAL POWER RECEPTACLE

A external power receptacle is integral to the power distribution module and allows the use of an external power source for cold weather starting or for lengthy maintenance work on electrical and avionics equipment. The receptacle is located on the left side of the cowl near the firewall. Access to the receptacle is gained by opening the receptacle door.

NOTE

Set the AVIONICS switches BUS 1 and BUS 2 to OFF if no avionics are required. If maintenance on the avionics equipment is required, a 28 VDC regulated and filtered external power source must be provided to prevent damage to the avionics equipment from transient voltages. Set AVIONICS switches BUS 1 and BUS 2 to OFF before starting the engine.

The following check should be made whenever the engine has been started using external power (after disconnecting the external power source).

1. MASTER Switch (ALT and BAT) - OFF
2. TAXI and LAND Light Switches - ON
3. Throttle Control - REDUCE TO IDLE
4. MASTER Switch (ALT and BAT) - ON (with taxi and landing lights turned on)
5. Throttle Control - INCREASE (to approximately 1500 RPM)
6. Main Battery (M BATT) Ammeter - CHECK (Battery charging, Amps Positive)
7. LOW VOLTS Annunciator - CHECK (Verify annunciator is not shown)

WARNING

IF M BATT AMMETER DOES NOT SHOW POSITIVE CHARGE (+ AMPS), OR LOW VOLTS ANNUNCIATOR DOES NOT GO OFF, REMOVE THE BATTERY FROM THE AIRPLANE AND SERVICE OR REPLACE THE BATTERY BEFORE FLIGHT.

LIGHTING SYSTEMS

EXTERIOR LIGHTING

Exterior lighting consists of navigation lights on the wing tips and the tip of the rudder, landing/taxi lights located on the left wing leading edge, a flashing beacon mounted on top of the vertical stabilizer, and a strobe light on each wing tip.

Two courtesy lights are recessed into the lower surfaces of each wing and provide illumination for each cabin door area. The switch for the courtesy lights is found on the pilot's overhead console. The rear dome light and under-wing courtesy lights share the same control switch. Pressing the rear dome light switch will make the lights come on and pressing it again will make the lights go out.

All other exterior lights are operated by switches found on the lighted switch panel to the left of the PFD. Exterior lights are grouped together in the LIGHTS section of the switch panel. To activate the BEACON, LAND (landing light), TAXI (taxi light), NAV, and STROBE light(s), place the switch in the up position. Circuit breakers for the lights are found on the lighted circuit breaker panel on the lower left instrument panel, below the PFD. Circuit breakers are grouped by electrical bus with BEACON and LAND on ELECTRICAL BUS 1 and TAXI, NAV and STROBE on ELECTRICAL BUS 2.

NOTE

The strobes and flashing beacon should not be used when flying through clouds or overcast; the flashing light reflected from water droplets or particles in the atmosphere, particularly at night, can produce vertigo and loss of orientation.

(Continued Next Page)

LIGHTING SYSTEMS (Continued)

INTERIOR LIGHTING

Interior lighting is controlled by a combination of dimmable crew area flood lighting, internally lit switch and circuit breaker panels, avionics panel lighting, standby instrument lighting, pedestal lighting, pilot control wheel map lighting and passenger area flood lighting.

Flood lighting is accomplished using two dimmable lights in the front crew area and one dome light in the rear passenger area. These lights are contained in the overhead console, and are controlled by dimmer controls for the front flood lights, and an on-off type push button switch for the rear dome light. The front flood lights can be rotated to provide directional lighting for the pilot and front passenger. The rear dome light provides for general illumination in the rear cabin area. The rear dome light and under-wing courtesy lights share the same switch.

Lighting of the switch panel, circuit breaker panel, engine controls and environmental control panel is accomplished by using internally lit panels. Rotating the SW/CB PANELS dimmer, found on the switch panel in the DIMMING group, controls the lighting level for both panels. Rotating the dimmer counterclockwise decreases light intensity from the highest level to off.

For airplane serials 18281869 and 18281876 thru 18282021 and 18282023 thru 18282045, pedestal lighting consists of three hooded lights found at various locations on the pedestal. Rotating the PEDESTAL light dimmer, found on the switch panel in the DIMMING group, controls the pedestal lights. Rotating the dimmer counterclockwise decreases light intensity from the highest level to off.

For airplane serials 18282022 and 18282046 and On, pedestal lighting is accomplished by using an internally lit panel for the cowl flap control lever, aux audio in jack and the 12 volt power outlet, along with a LED strip light located at the top of the pedestal. Lighting for the fuel selector valve is accomplished by a LED strip light incorporated into the bottom of the internally lit cowl flap control panel. Rotating the PEDESTAL light dimmer, found on the switch panel in the DIMMING group, controls the pedestal lights. Rotating the dimmer counterclockwise decreases light intensity from the highest level to off.

(Continued Next Page)

LIGHTING SYSTEMS (Continued)

INTERIOR LIGHTING (Continued)

Avionics panel lighting consists of the PFD and MFD bezel and display lighting and Audio Panel lighting. Rotating the AVIONICS dimmer, found on the switch panel in the DIMMING group, controls the lighting level. Positioning the dimmer control in the off position (fully counterclockwise) causes the avionics displays to use internal photocells to automatically control the lighting levels. This is the recommended use of the avionics lighting for all day and lower lighting levels where lighting of the avionics bezels and keys is not required. In low to night lighting levels rotating the AVIONICS dimmer control clockwise from the off position places all avionics lighting level control to the AVIONICS dimmer control. This is the recommended use of avionics lighting for night and low lighting conditions to allow the pilot control of the avionics illumination levels as dark adaptation occurs.

Rotating the STBY IND dimmer, found on the switch panel in the DIMMING group, controls lighting of the standby airspeed indicator, attitude indicator, altimeter and non-stabilized magnetic compass. Rotating the dimmer counterclockwise decreases light intensity from the highest level to off.

Pilot's chart (map) lighting is accomplished by use of a rheostat and a light assembly, both found on the lower surface of the pilot's control wheel. The light provides downward illumination from the bottom of the control wheel to the pilot's lap area. To operate the light, first turn the NAV light switch ON, and then adjust the map light intensity using the knurled rheostat knob. Rotating the dimmer clockwise (when facing up) increases light intensity, and rotating the dimmer counterclockwise decreases light intensity.

Regardless of the light system in question, the most probable cause of a light failure is a burned out bulb. However, in the event any lighting systems fails to come on, check the appropriate circuit breaker. For the interior lights the PANEL LTS circuit breaker, and for the exterior lights the associated light function circuit breaker (i.e. landing light, LAND LT circuit breaker). If the circuit breaker has opened, and there is no obvious indication of a short circuit (smoke or odor), turn the affected lights OFF, reset the circuit breaker, and turn the lights ON again. If the circuit breaker opens again, do not reset until maintenance has been performed.

CABIN HEATING, VENTILATING AND DEFROSTING SYSTEM

The temperature and volume of airflow into the cabin can be regulated by manipulation of the push-pull CABIN HT and CABIN AIR controls (Refer to Figure 7-8). Both controls are the double button locking-type and permit intermediate settings.

For cabin ventilation, pull the CABIN AIR knob out. To raise the air temperature, pull the CABIN HT knob out approximately 1/4 to 1/2 inch for a small amount of cabin heat. Additional heat is available by pulling the knob out farther; maximum heat is available with the CABIN HT knob pulled out and the CABIN AIR knob pushed full in. When no heat is desired in the cabin, the CABIN HT knob is pushed full in.

Front cabin heat and ventilating air is supplied by outlet holes spaced across a cabin manifold just forward of the pilot's and front passenger's feet. Rear cabin heat and air is supplied by two ducts from the manifold, one extending down each side of the cabin to an outlet just aft of the rudder pedals at floor level. Windshield defrost air is also supplied by two ducts from the cabin manifold outlet on top of the glareshield; therefore, the temperature of the defrosting air is the same as heated cabin air. A rotating control knob, labeled DEFROST, regulates the volume of air to the windshield. Turn the knob clockwise to ON and counterclockwise to OFF.

Separate adjustable ventilators supply additional air; one near each upper corner of the windshield supplies air for the pilot and front passenger, and two ventilators are available for the rear cabin area to supply air to the rear seat passengers. There are additional ventilators located in various positions in the cockpit.

CABIN HEATING, VENTILATION AND DEFROSTING SYSTEM

B6428

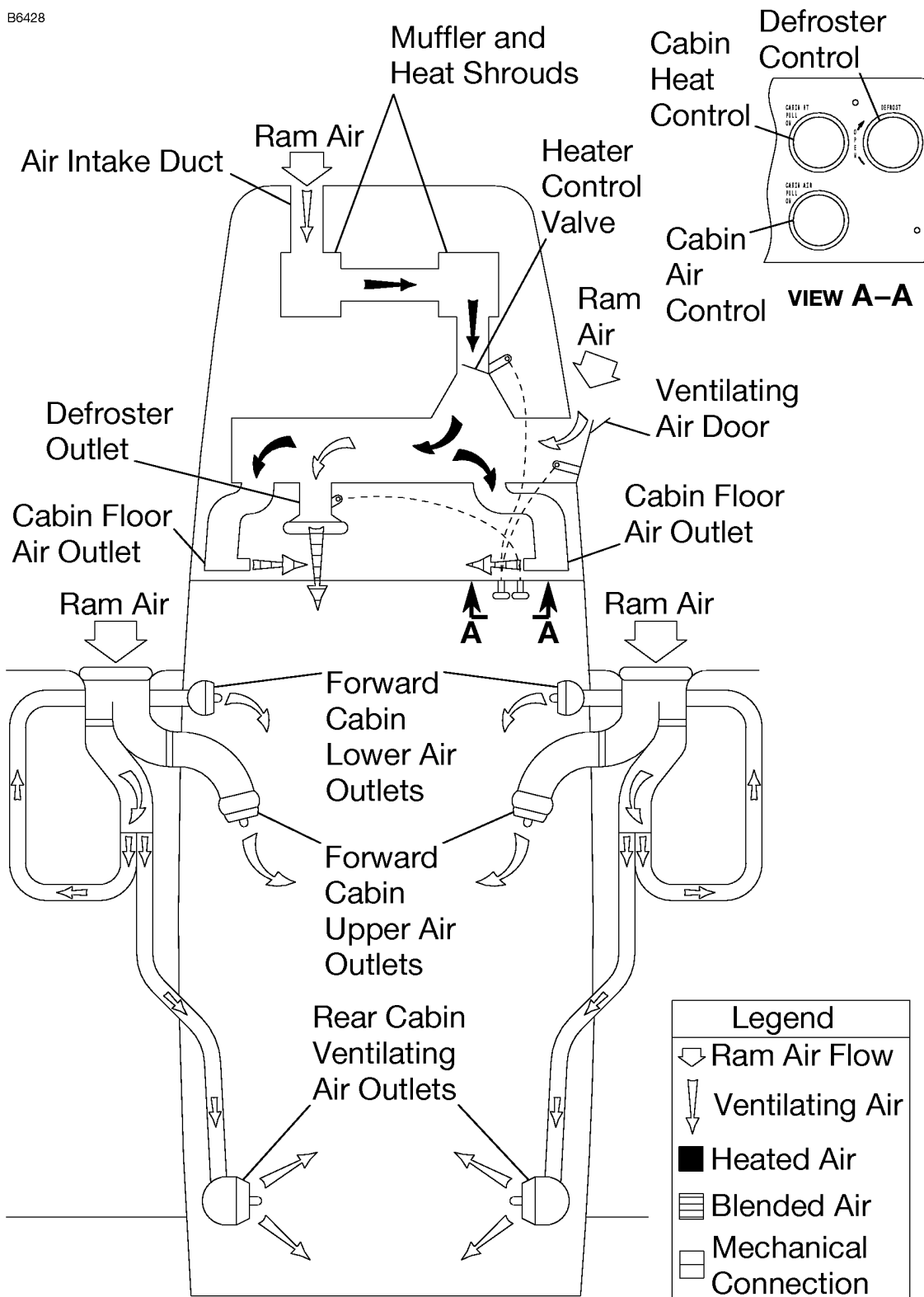

0785T1014
 AA0785T1029

Figure 7-8

PITOT-STATIC SYSTEM AND INSTRUMENTS

The pitot-static system uses a heated total pressure (pitot) head mounted on the lower surface of the left wing, external static ports mounted on both sides of the forward fuselage and associated plumbing to connect the air data computer and the conventional pitot-static instruments to the sources.

The heated pitot system uses an electrical heating element built in the body of the pitot head. The PITOT HEAT control switch is found on the switch panel below the lower left corner of the PFD. The PITOT HEAT circuit breaker is found on the circuit breaker panel at the lower left side of the pilot panel.

A static pressure alternate source valve (ALT STATIC AIR) is located adjacent to the throttle control. The ALT STATIC AIR valve provides static pressure from inside the cabin if the external static pressure source becomes blocked.

If erroneous instrument readings are suspected due to water or ice in the pressure line going to the standard external static pressure source, the alternate static source valve should be pulled on.

Pressures within the cabin will vary with open heaters/vents and windows. Refer to Section 5, Figure 5-1 (Sheet 2), for the Airspeed Calibration, Alternate Static Source correction chart and Figure 5-2 for the Altimeter Correction, Alternate Static Source correction chart.

VACUUM SYSTEM AND INSTRUMENTS

The vacuum system (Refer to Figure 7-9) provides the vacuum necessary to operate the standby attitude indicator. The system consists of one engine driven vacuum pump, a vacuum regulator, the standby attitude indicator, a vacuum system air filter, and a vacuum transducer. The vacuum transducer provides a signal to the engine display that is processed and displayed as vacuum on the EIS SYSTEM page. If available vacuum, from the engine-driven vacuum pump, drops below 3.5 in.hg., the LOW VACUUM annunciator will display in amber on the PFD.

ATTITUDE INDICATOR

The standby attitude indicator is a vacuum-powered gyroscopic instrument, found on the center instrument panel below the MFD. The attitude indicator includes a low-vacuum warning flag (GYRO) that comes into view when the vacuum is below the level necessary for reliable gyroscope operation.

VACUUM INDICATOR

The vacuum indicator is incorporated on the EIS SYSTEM page, found along the left side of the PFD during engine start or the left edge of the MFD during normal operation. During reversionary operation, the EIS bar appears along the left side of the operational display.

LOW VACUUM ANNUNCIATION

- A low vacuum condition is annunciated along the right side of the PFD by a amber LOW VACUUM annunciator.

VACUUM SYSTEM

B3756

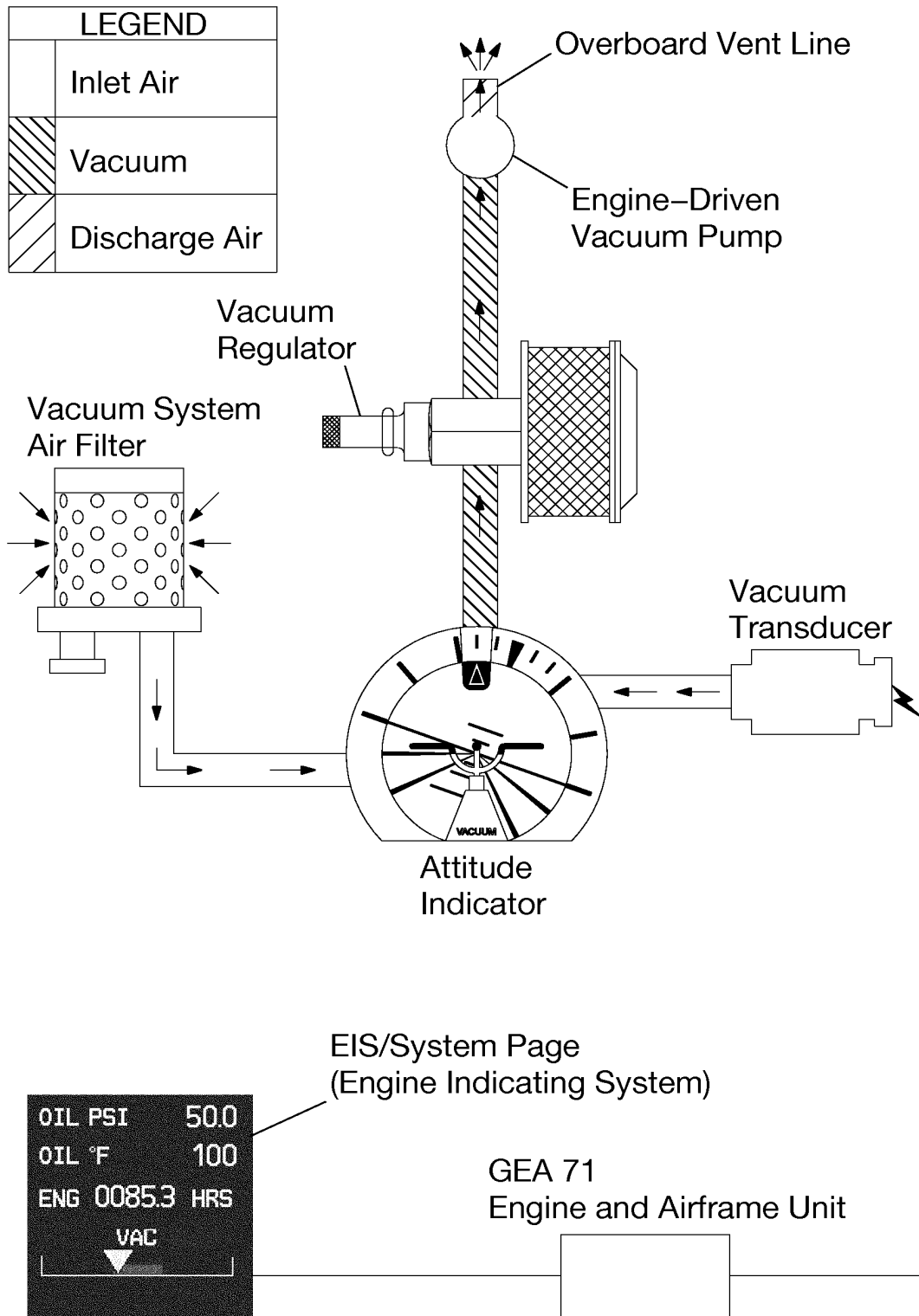

A0785T1013A

Figure 7-9

CLOCK/O.A.T. INDICATOR

A numerical time or clock window (based on GPS time) and an outside air temperature (O.A.T.) indicator window are provided along the lower edge of the PFD. The O.A.T. indicator uses an air temperature sensor located on top of the cabin.

STALL WARNING SYSTEM

The airplane is equipped with a vane-type stall warning system consisting of an inlet in the leading edge of the left wing, which is electrically connected to a stall warning horn located in the headliner above the left cabin door. A 5-amp push-to-reset circuit breaker labeled WARN, on the left side of the circuit breaker panel, protects the stall warning system. The vane in the wing senses the change in airflow over the wing, and operates the warning horn at airspeeds between 5 and 10 knots above the stall in all configurations.

The airplane has a heated stall warning system, the vane and sensor unit in the wing leading edge is equipped with a heating element. The heated part of the system is operated by the PITOT HEAT switch, and is protected by the PITOT HEAT circuit breaker.

The stall warning system should be checked during the preflight inspection by momentarily turning on the MASTER switch and actuating the vane in the wing. The system is operational if the warning horn sounds as the vane is pushed upward.

STANDARD AVIONICS

The Garmin G1000 Avionics System is an integrated flight control and navigation system. The system combines primary flight instruments, communications, airplane system information and navigational information all displayed on two color displays. The G1000 system consists of the following pieces of equipment:

GARMIN DISPLAY UNITS (GDU)

Two identical units are mounted on the instrument panel. One, located in front of the pilot, is configured as a PFD. A second panel, located to the right, is configured as a MFD.

The PFD displays roll and pitch information, heading and course navigation information, plus altitude, airspeed and vertical speed information to the pilot. The PFD also controls and displays all communication and navigation frequencies as well as displaying warning/status annunciations of airplane systems.

The MFD displays a large scalable, moving map that corresponds to the airplane's current location. Data from other components of the system can be overlaid on this map. Location and direction of movement of nearby aircraft, lightning and weather information can all be displayed on the MFD. The MFD is also the principle display for all of the engine, fuel, and electrical system parameters.

The reversionary mode places the flight information and basic engine information on both the PFD and the MFD. This feature allows the pilot full access to all necessary information should either of the display screens malfunction.

(Continued Next Page)

STANDARD AVIONICS (Continued)

AUDIO PANEL (GMA)

The audio panel for the G1000 system integrates all of the communication and navigation digital audio signals, intercom system and marker beacon controls in one unit. It is installed on the instrument panel between the PFD and the MFD. The audio panel also controls the reversionary mode for the PFD and MFD.

NOTE

Use of the COM 1/2 function is not approved.

INTEGRATED AVIONICS UNIT (GIA)

Two integrated avionics units are installed in the G1000 system. They are mounted in racks in the tailcone, behind the baggage curtain. These units act as the main communications hub linking all of the other peripheral parts to the GDU displays. Each unit contains a GPS receiver, a VHF navigation receiver, VHF communication transceiver and the main system microprocessors. The first GIA unit to acquire a GPS satellite 3-D navigation signal is the active GPS source.

ATTITUDE AND HEADING REFERENCE SYSTEM (AHRS) AND MAGNETOMETER (GRS)

The AHRS provides airplane attitude and flight characteristics information to the G1000 displays and to the integrated avionics units, which is located in the tailcone of the airplane. The AHRS unit contains accelerometers, tilt sensors and rate sensors that replace spinning mass gyros used in other airplanes. The magnetometer is located inside the left wing panel and interfaces with the AHRS to provide heading information.

(Continued Next Page)

STANDARD AVIONICS (Continued)

AIR DATA COMPUTER (GDC)

The Air Data Computer (ADC) compiles information from the airplane's pitot/static system. The ADC unit is mounted behind the instrument panel, just forward of the MFD. An outside air temperature probe, mounted on top of the cabin, is connected to the ADC. The ADC calculates pressure altitude, airspeed, true airspeed, vertical speed and outside air temperature.

ENGINE MONITOR (GEA)

The Engine Monitor is responsible for receiving and processing the signals from all of the engine and airframe sensors. It is connected to all of the CHT measuring sensors, EGT sensors, manifold pressure, RPM, fuel flow and to the fuel gauging system. This unit transmits this information to the engine display computers.

TRANSPONDER (GTX)

The full-featured Mode S transponder provides Mode A, C and S functions. Control and operation of the transponder is accomplished using the PFD. The transponder unit is mounted in the tailcone avionics racks.

XM WEATHER AND RADIO DATA LINK (GDL)

The XM weather and radio data link provides weather information and digital audio entertainment in the cockpit. The unit is mounted behind the instrument panel, just forward of the MFD. This unit communicates with the MFD on the high-speed data bus. XM weather and XM radio operate in the S-band frequency range to provide continuous uplink capabilities at any altitude throughout North America. A subscription to the XM satellite radio service is required for the XM weather and radio data link to be used.

(Continued Next Page)

STANDARD AVIONICS (Continued)

GFC 700 AUTOMATIC FLIGHT CONTROL SYSTEM (AFCS)

Refer to the Garmin G1000 CRG for more information on system operation.

CONTROL WHEEL STEERING (CWS)

The Control Wheel Steering (CWS) button, located on the pilot's control wheel, immediately disconnects the pitch and roll servos when activated. Large pitch changes while using CWS will cause the airplane to be out of trim. Retrim the airplane as necessary during CWS operation to reduce control forces or large pitch oscillations that may occur after releasing the CWS button.

WARNING

WHEN THE AUTOPILOT IS ENGAGED IN NAV, APR OR BC OPERATING MODES, IF THE HSI NAVIGATION SOURCE IS CHANGED MANUALLY, USING THE CDI SOFTKEY, THE CHANGE WILL INTERRUPT THE NAVIGATION SIGNAL TO THE AUTOPILOT AND WILL CAUSE THE AUTOPILOT TO REVERT TO ROL MODE OPERATION. NO AURAL ALERT WILL BE PROVIDED. IN ROL MODE, THE AUTOPILOT WILL ONLY KEEP THE WINGS LEVEL AND WILL NOT CORRECT THE AIRPLANE HEADING OR COURSE. SET THE HDG BUG TO THE CORRECT HEADING AND SELECT THE CORRECT NAVIGATION SOURCE ON THE HSI, USING THE CDI SOFTKEY, BEFORE ENGAGING THE AUTOPILOT IN ANY OTHER OPERATING MODE.

GFC 700 SYSTEM SCHEMATIC

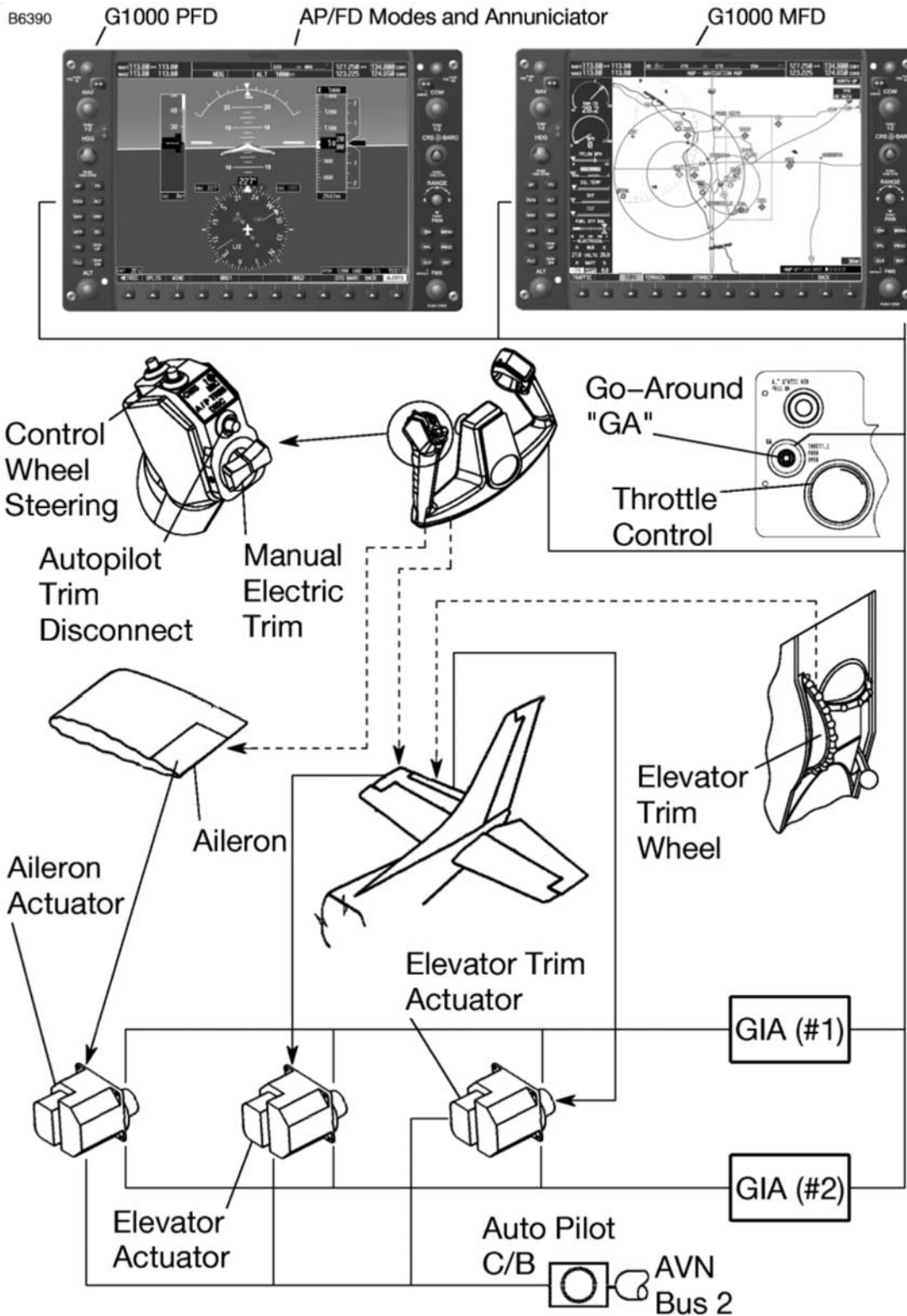

Figure 7-10

STANDARD AVIONICS (Continued)

L3 COMMUNICATIONS WX-500 STORMSCOPE

Refer to Section 9, Supplement 3, for operating information.

BENDIX/KING KTA 870 TRAFFIC ADVISORY/MULTI-HAZARD AWARENESS SYSTEM

The Bendix/King KTA 870 Traffic Advisory/Multi-Hazard Awareness System provides the pilot with supplemental flight information through the G1000 system. This system includes a Traffic Advisory System (TAS) for air traffic and an Enhanced Ground Proximity Warning System (EGPWS) for terrain. The KTA 870 unit is mounted in the tailcone avionics racks. Refer to the Bendix/King KTA 870/KMH 880 Traffic Advisory System/Multi-Hazard Awareness System Pilot's Guide, Honeywell part number 006-18265-0000, Revision 3, dated January 2005, or later revision and the Garmin G1000 CRG for more information on system operation of the KTA 870 system.

NOTE

When TAS is enabled TIS will be unavailable.

AVIONICS SUPPORT EQUIPMENT

Avionics cooling fans, antennas, microphone and headset provisions, power converter and static discharge wicks support the operation of the avionics equipment installations.

AVIONICS COOLING FANS

Four DC electric fans provide forced air and ambient air circulation cooling for the G1000 avionics equipment. A single fan in the tailcone provides forced air cooling to the integrated avionics units and to the transponder. A fan located forward of the instrument panel removes air from between the firewall bulkhead and instrument panel, directing the warm air up at the inside of the windshield. Two additional fans blow air directly onto the heat sinks located on the forward sides of the PFD and MFD.

Power is provided to these fans when the MASTER (BAT) switch and the AVIONICS (BUS 1 and BUS 2) switch are all ON.

NOTE

None of the cooling fans will operate when the essential bus avionics equipment is being powered by the standby battery.

(Continued Next Page)

AVIONICS SUPPORT EQUIPMENT (Continued)

ANTENNAS

Two combination VHF COM/GPS antennas are mounted on the top of the cabin. The dual-mode COM 1/GPS 1 antenna is mounted on the right side. Earlier production airplanes are configured with a tri-mode COM 2/GPS 2/XM antenna mounted on the left side, while later production airplanes are configured with a dual-mode COM 2/GPS 2 antenna mounted on the left side and a separate XM antenna mounted on top of the cabin. The combination VHF COM/GPS antennas are connected to the two VHF communication transceivers, the two GPS receivers in the integrated avionics units, and the GDL.

A blade-type navigation antenna is mounted on either side of the vertical stabilizer. This antenna provides VOR and glideslope signals to the VHF navigation receivers contained in the integrated avionics units.

The marker beacon antenna is mounted on the bottom of the tailcone. It provides the signal to the marker beacon receiver located in the audio panel.

The transponder antenna is mounted on the bottom of the cabin and is connected to the Mode S transponder by a coaxial transmission cable.

The L3 Communications WX-500 Stormscope antenna is mounted on the bottom of the tailcone and is connected to the L3 Communications WX-500 Stormscope receiver by an antenna cable assembly.

The Bendix/King Distance Measuring Equipment (DME) antenna (if installed) is mounted on the bottom of the tailcone and is connected to the Bendix/King DME receiver by a coaxial cable.

The Bendix/King Traffic Advisory System (TAS) (if installed) has two antennas. A directional antenna is mounted on top of the cabin forward of the COM antennas and an omni-directional antenna is mounted on the bottom of the tailcone. Both antennas are connected to the Bendix/King TAS receiver by coaxial cables.

(Continued Next Page)

AVIONICS SUPPORT EQUIPMENT (Continued)

MICROPHONE AND HEADSET INSTALLATIONS

Standard equipment for the airplane includes a hand-held microphone, an overhead speaker, two remote-keyed microphone switches on the control wheels, and provisions for communications headsets at each pilot and passenger station.

The hand-held microphone includes an integral push-to-talk switch. This microphone is plugged in at the center pedestal and is accessible to both the pilot and front passenger. Pressing the push-to-talk switch allows voice transmission on the COM radios.

The overhead speaker is located in the center overhead console. Volume and output for this speaker are controlled through the audio panel.

Each control wheel contains a push-to-talk switch. This switch allows the pilot or front passenger to transmit on the COM radios using remote microphones.

Each seat position of the airplane has provisions for aviation-style headsets. Microphone and headphone jacks are located on each respective sidewall panel for communications between passengers and pilot. The system is designed so that microphones are voice activated. Only the pilot or front passenger can transmit through the COM radios.

NOTE

To ensure audibility and clarity when transmitting with the hand-held microphone, always hold it as closely as possible to the lips, then press the transmit switch and speak directly into it. Avoid covering the opening on back side of microphone for optimum noise canceling.

(Continued Next Page)

AVIONICS SUPPORT EQUIPMENT (Continued)

AUXILIARY AUDIO INPUT JACK

An auxiliary audio input jack (AUX AUDIO IN) is located on the right side of the center pedestal (Refer to Figure 7-2). It allows entertainment audio devices such as cassette, compact disc, and MP3 players to play music over the airplane's headsets.

The signal from AUX AUDIO IN is automatically muted during radio communications or pilot selection of crew intercom isolation modes located on the audio panel. The AUX key on the audio panel does not control the AUX AUDIO IN signal. For a more complete description and operating instructions of the audio panel, refer to the Garmin G1000 CRG.

Since the entertainment audio input is not controlled by a switch, there is no way to deselect the entertainment source except to disconnect the source at the audio input connector. In the event of a high pilot workload and/or heavy traffic, it is wise to disable the entertainment audio to eliminate a source of distraction for the flight crew.

NOTE

- Passenger briefing should specify that AUX AUDIO IN (entertainment audio input) and Portable Electronic Device (PED) use is permitted only during the enroute phase of flight.
- Disconnect the cable from the AUX AUDIO IN jack when not in use.
- Use caution with audio cables in the cabin to avoid entangling occupants or cabin furnishings and to prevent damage to cables.

(Continued Next Page)

AVIONICS SUPPORT EQUIPMENT (Continued)

12V POWER OUTLET

A power converter, located on the cabin side of the firewall just forward of the right instrument panel, reduces the airplane's 28 VDC power to 12 VDC. This converter provides up to 10 amps of power to operate portable devices such as notebook computers and audio players. The power output connector (POWER OUTLET 12V -10A) is located on the center pedestal (Refer to Figure 7-2).

A second power outlet connector (POWER OUTLET 12V - 10A) is located in the right sidewall by the aft passenger seat. A switch located on the switch panel labeled CABIN PWR 12V controls the operation of the power outlets.

NOTE

- Charging of lithium batteries may cause the lithium batteries to explode.
- Take care to observe the manufacturer's power requirements prior to plugging any device into the 12 volt cabin power system connector. This system is limited to a maximum of 10 amps, or if equipped with two connectors 10 amps total.
- Use caution with power/adaptor cables in the cabin to avoid entangling occupants or cabin furnishings and to prevent damage to cables supplying live electric current.
- Disconnect power/adaptor cables when not in use.

(Continued Next Page)

AVIONICS SUPPORT EQUIPMENT (Continued)

STATIC DISCHARGERS

Static dischargers are installed at various points throughout the airframe to reduce interference from precipitation static. Under some severe static conditions, loss of radio signals is possible even with static dischargers installed. Whenever possible, avoid known severe precipitation areas to prevent loss of dependable radio signals. If avoidance is impractical, minimize airspeed and anticipate temporary loss of radio signals while in these areas.

Static dischargers lose their effectiveness with age, and therefore, should be checked periodically (at least at every annual inspection) by a qualified technician.

CABIN FEATURES

EMERGENCY LOCATOR TRANSMITTER (ELT)

Refer to Section 9, Supplements 1 or 2, for ELT operating information.

CABIN FIRE EXTINGUISHER

A portable Halon 1211 (Bromochlorodifluoromethane) fire extinguisher is installed in a holder on the floorboard between the front seats to be accessible in case of fire. The extinguisher is classified 5B:C by Underwriters Laboratories.

The extinguisher should be checked prior to each flight to ensure that the pressure of the contents, as indicated by the gage at the top of the extinguisher, is within the green arc (approximately 125 psi) and the operating lever lock pin is securely in place.

To operate the fire extinguisher:

1. Loosen retaining clamp(s) and remove extinguisher from bracket.
2. Hold extinguisher upright, pull operating ring pin, and press lever while directing the liquid at the base of the fire at the near edge. Progress toward the back of the fire by moving the nozzle rapidly with a side-to-side sweeping motion.

WARNING

VENTILATE THE CABIN PROMPTLY AFTER SUCCESSFULLY EXTINGUISHING THE FIRE TO REDUCE THE GASES PRODUCED BY THERMAL DECOMPOSITION.

3. The contents of the cabin fire extinguisher will empty in approximately eight seconds of continuous use.

Fire extinguishers should be recharged by a qualified fire extinguisher agency after each use. After recharging, secure the extinguisher to its mounting bracket.

(Continued Next Page)

CABIN FEATURES (Continued)

CARBON MONOXIDE DETECTION SYSTEM

The carbon monoxide (CO) detection system consist of a single detector located behind the instrument panel, powered by the airplanes DC electrical system and integrated in the Garmin G1000 system with a warning annunciation and alert messages displayed on the PFD.

When the CO detection system senses a CO level of 50 parts-per-million (PPM) by volume or greater the alarm turns on a flashing warning annunciation, CO LVL HIGH, in the annunciation window on the PFD with a continuous tone until the PFD softkey below WARNING is pushed. It then remains on steady until the CO level drops below 50 PPM and automatically resets the alarm.

If the CO system detects a problem within the system that requires service, a CO DET SRVC message is displayed in the alerts window of the PFD. If there is an interface problem between the G1000 system and the CO system a CO DET FAIL message is displayed in the alerts window of the PFD.

AIRPLANE HANDLING, SERVICE AND MAINTENANCE

TABLE OF CONTENTS

	Page
Introduction	8-3
Identification Plate	8-4
Cessna Owner Advisories	8-4
United States Airplane Owners	8-4
International Airplane Owners	8-4
Publications	8-5
Airplane File	8-6
Airplane Inspection Periods	8-7
FAA Required Inspections	8-7
Cessna Inspection Programs	8-7
Cessna Customer Care Program	8-8
Pilot Conducted Preventive Maintenance	8-8
Alterations Or Repairs	8-9
Ground Handling	8-9
Towing	8-9
Parking	8-9
Tiedown	8-10
Jacking	8-10
Leveling	8-11
Flyable Storage	8-11
Servicing	8-12
Oil	8-13
Oil Specification	8-13
Recommended Viscosity For Temperature Range	8-13
Capacity Of Engine Sump	8-14
Oil And Oil Filter Change	8-14

(Continued Next Page)

TABLE OF CONTENTS (Continued)

	Page
Fuel	8-15
Approved Fuel Grades (And Colors)	8-15
Fuel Capacity	8-15
Fuel Additives	8-16
Fuel Contamination	8-20
Landing Gear	8-21
Cleaning And Care	8-22
Windshield And Windows	8-22
Painted Surfaces	8-23
Propeller Care	8-24
Engine Care	8-24
Interior Care	8-25/8-26
Avionics Care	8-25/8-26

INTRODUCTION

This section contains factory recommended procedures for proper ground handling and routine care and servicing of your airplane. It also identifies certain inspection and maintenance requirements which must be followed if your airplane is to retain that new airplane performance and dependability. It is important to follow a planned schedule of lubrication and preventive maintenance based on climatic and flying conditions encountered in your local area.

Keep in touch with your local Cessna Service Station and take advantage of their knowledge and experience. Your Cessna Service Station knows your airplane and how to maintain it, and will remind you when lubrications and oil changes are necessary, as well as other seasonal and periodic services.

The airplane should be regularly inspected and maintained in accordance with information found in the airplane maintenance manual and in company issued service bulletins and service newsletters. All service bulletins pertaining to the airplane by serial number should be accomplished and the airplane should receive repetitive and required inspections. Cessna does not condone modifications, whether by Supplemental Type Certificate (STC) or otherwise, unless these certificates are held and/or approved by Cessna. Other modifications may void warranties on the airplane since Cessna has no way of knowing the full effect on the overall airplane. Operation of an airplane that has been modified may be a risk to the occupants, and operating procedures and performance data set forth in the POH may no longer be considered accurate for the modified airplane.

IDENTIFICATION PLATE

All correspondence regarding your airplane should include the Serial Number. The Serial Number, Model Number, Production Certificate Number (PC) and Type Certificate Number (TC) can be found on the Identification Plate, located on the aft left tailcone. The Finish and Trim Plate, which is installed on the lower part of the left forward doorpost, contains a code describing the exterior paint combination of the airplane. The code may be used in conjunction with an applicable Illustrated Parts Catalog if finish and trim information is needed.

CESSNA OWNER ADVISORIES

Cessna Owner Advisories are sent to Cessna Aircraft FAA Registered owners of record at no charge to inform them about mandatory and/or beneficial airplane service requirements and product changes. Copies of the actual bulletins are available from Cessna Service Stations and Cessna Propeller Aircraft Customer Services.

UNITED STATES AIRPLANE OWNERS

If your airplane is registered in the U.S., appropriate Cessna Owner Advisories will be mailed to you automatically according to the latest airplane registration name and address which you have provided to the FAA. Therefore, it is important that you provide correct and up to date mailing information to the FAA.

If you require a duplicate Owner Advisory to be sent to an address different from the FAA aircraft registration address, please complete and return an Owner Advisory Application (otherwise no action is required on your part).

INTERNATIONAL AIRPLANE OWNERS

To receive Cessna Owner Advisories, please complete and return an Owner Advisory Application.

Receipt of a valid Owner Advisory Application will establish your Cessna Owner Advisory service for one year, after which you will be sent a renewal notice. It is important that you respond promptly to update your address for this critical service.

PUBLICATIONS

Various publications and flight operation aids are furnished in the airplane when delivered from the factory. These items are listed below.

- Customer Care Program Handbook
- Pilot's Operating Handbook and FAA Approved Airplane Flight Manual
- Pilot's Checklist
- Passenger Briefing Card
- Cessna Service Station Directory

To obtain additional publications or owner advisory information, you may contact Cessna Propeller Aircraft Customer Services at (316) 517-5800. Fax (316) 517-7271 or write to Cessna Aircraft Company, P.O. Box 7706, Wichita, KS 67277, Dept 751C.

The following additional publications, plus many other supplies that are applicable to your airplane, are available from a Cessna Service Station.

- Information Manual (contains Pilot's Operating Handbook Information)
- Maintenance Manual, Wiring Diagram Manual and Illustrated Parts Catalog

Cessna Service Stations have a Customer Care Supplies and Publications Catalog covering all available items, many of which the Service Station keeps on hand. The Service Station can place an order for any item which is not in stock.

NOTE

A Pilot's Operating Handbook and FAA Approved Airplane Flight Manual which is lost or destroyed may be replaced by contacting a Cessna Service Station. An affidavit containing the owner's name, airplane serial number and reason for replacement must be included in replacement requests since the Pilot's Operating Handbook and FAA Approved Airplane Flight Manual is identified for specific serial numbered airplanes only.

AIRPLANE FILE

There are miscellaneous data, information and licenses that are a part of the airplane file. The following is a checklist for that file. In addition, a periodic check should be made of the latest Federal Aviation Regulations to ensure that all data requirements are met.

To be displayed in the airplane at all times:

1. Aircraft Airworthiness Certificate (FAA Form 8100-2).
2. Aircraft Registration Certificate (FAA Form 8050-3).
3. Aircraft Radio Station License, (if applicable).

To be carried in the airplane at all times:

1. Current Pilot's Operating Handbook and FAA Approved Airplane Flight Manual.
2. Garmin G1000 Cockpit Reference Guide (190-00384-00 Rev. B or subsequent).
3. Weight and Balance, and associated papers (latest copy of the Repair and Alteration Form, FAA Form 337, if applicable).
4. Equipment List.

To be made available upon request:

1. Airplane Logbook.
2. Engine Logbook.

Most of the items listed are required by the United States Federal Aviation Regulations. Since the Regulations of other nations may require other documents and data, owners of airplanes not registered in the United States should check with their own aviation officials to determine their individual requirements.

Cessna recommends that these items, plus the Pilot's Checklists, Customer Care Program Handbook and Customer Care Card, be carried in the airplane at all times.

AIRPLANE INSPECTION PERIODS

FAA REQUIRED INSPECTIONS

As required by U.S. Federal Aviation Regulations, all civil aircraft of U.S. registry must undergo a complete inspection (annual) each twelve calendar months. In addition to the required annual inspection, aircraft operated commercially (for hire) must have a complete inspection every 100 hours of operation.

The FAA may require other inspections by the issuance of airworthiness directives applicable to the airplane, engine, propeller and components. It is the responsibility of the owner/operator to ensure compliance with all applicable airworthiness directives, and when the inspections are repetitive, to take appropriate steps to prevent inadvertent noncompliance.

CESSNA INSPECTION PROGRAMS

In lieu of the 100 hour and annual inspection requirements, an airplane may be inspected in accordance with a Progressive Care Inspection Program or a PhaseCard Inspection Program. Both programs offer systems which allow the work load to be divided into smaller operations that can be accomplished in shorter time periods.

The Cessna Progressive Care Inspection Program allows an airplane to be inspected and maintained in four operations. The four operations are recycled each 200 hours and are recorded in a specially provided Aircraft Inspection Log as each operation is conducted.

The PhaseCard Inspection Program offers a parallel system for high-utilization flight operations (approximately 600 flight hours per year). This system utilizes 50 hour intervals (Phase 1 and Phase 2) to inspect high-usage systems and components. At 12 months or 600 flight hours, whichever occurs first, the airplane undergoes a complete (Phase 3) inspection.

Regardless of the inspection method selected, the owner should keep in mind that 14 CFR 43 and 14 CFR 91 establishes the requirement that properly certified agencies or personnel accomplish all required FAA inspections and most of the manufacturer recommended inspections.

(Continued Next Page)

AIRPLANE INSPECTION PERIODS (Continued)

CESSNA CUSTOMER CARE PROGRAM

Specific benefits and provisions of the Cessna Warranty plus other important benefits for you are contained in your Customer Care Program Handbook supplied with your airplane. The Customer Care Program Handbook should be thoroughly reviewed and kept in the airplane at all times.

You will also want to return to your Cessna Service Station either at 50 hours for your first Progressive Care Operation, or at 100 hours for your first 100 hour inspection depending on which program you choose to establish for your airplane. While these important inspections will be performed for you by any Cessna Service Station, in most cases you will prefer to have the Cessna Service Station from whom you purchased the airplane accomplish this work.

PILOT CONDUCTED PREVENTIVE MAINTENANCE

A certified pilot who owns or operates an airplane not used as an air carrier is authorized by 14 CFR 43 to perform limited maintenance on his airplane. Refer to 14 CFR 43 for a list of the specific maintenance operations which are allowed.

NOTE

Pilots operating airplanes of other than U.S. registry should refer to the regulations of the country of certification for information on preventive maintenance that may be performed by pilots.

A Maintenance Manual must be obtained prior to performing any preventive maintenance to ensure that proper procedures are followed. A Cessna Service Station should be contacted for further information or for required maintenance which must be accomplished by appropriately licensed personnel.

ALTERATIONS OR REPAIRS

It is essential that the FAA be contacted prior to any alterations on the airplane to ensure that airworthiness of the airplane is not violated. Alterations or repairs to the airplane must be accomplished by licensed personnel, utilizing only FAA Approved components and FAA Approved data, such as Cessna Service Bulletins.

GROUND HANDLING

TOWING

The airplane is most easily and safely maneuvered by hand with the tow bar attached to the nosewheel (the tow bar is stowed on the side of the baggage area). When towing with a vehicle, do not exceed the nose gear turning angle of 29° either side of center, or damage to the nose landing gear will result.

CAUTION

REMOVE ANY INSTALLED RUDDER LOCK BEFORE TOWING.

If the airplane is towed or pushed over a rough surface during hangaring, watch that the normal cushioning action of the nose strut does not cause excessive vertical movement of the tail and the resulting contact with low hangar doors or structure. A flat nose tire or deflated strut will also increase tail height.

PARKING

When parking the airplane, head into the wind and set the parking brake. Do not set the parking brake during cold weather when accumulated moisture may freeze the brakes, or when the brakes are overheated. Install the control wheel lock and chock the wheels. In severe weather and high wind conditions, tie the airplane down as outlined in the following paragraph.

(Continued Next Page)

GROUND HANDLING (Continued)

TIEDOWN

Proper tiedown procedure is the best precaution against damage to the parked airplane by gusty or strong winds. To tiedown the airplane securely, proceed as follows:

1. Set the parking brake and install the control wheel lock.
2. Install a surface control lock over the fin and rudder.
3. Tie sufficiently strong ropes or chains (700 pounds tensile strength) to the wing, tail and nose tiedown fittings and secure each rope or chain to a ramp tiedown.
4. Install a pitot tube cover.

JACKING

When a requirement exists to jack the entire airplane off the ground, or when wing jack points are used in the jacking operation, refer to the Maintenance Manual for specific procedures and equipment required.

Individual main gear may be jacked by using the jack pad which is incorporated in the main landing gear strut step bracket. When using the individual gear strut jack pad, flexibility of the gear strut will cause the main wheel to slide inboard as the wheel is raised, tilting the jack. The jack must then be lowered for a second jacking operation. Do not jack both main wheels simultaneously using the individual main gear jack pads.

CAUTION

DO NOT APPLY PRESSURE ON THE ELEVATOR OR HORIZONTAL STABILIZER SURFACES. WHEN PUSHING ON THE TAILCONE, ALWAYS APPLY PRESSURE AT A BULKHEAD TO AVOID BUCKLING THE SKIN.

If nose gear maintenance is required, the nosewheel may be raised off the ground by pressing down on a tailcone bulkhead, just forward of the horizontal stabilizer, and allowing the tail to rest on the tail tiedown ring.

(Continued Next Page)

GROUND HANDLING (Continued)

JACKING (Continued)

To assist in raising and holding the nosewheel off the ground, ground anchors should be utilized at the tail tiedown point.

NOTE

Ensure that the nose will be held off the ground under all conditions by means of suitable stands or supports under weight supporting bulkheads near the nose of the airplane.

LEVELING

Longitudinal leveling of the airplane is accomplished by placing a level on leveling screws located on the left side of the tailcone. Deflate the nose tire and/or lower or raise the nose strut to properly center the bubble in the level. Corresponding points on both upper door sills may be used to level the airplane laterally.

FLYABLE STORAGE

Engines in airplanes that are flown every 30 days or less may not achieve normal service life because of internal corrosion. Corrosion occurs when moisture from the air and the products of combustion combine to attack cylinder walls and bearing surfaces during periods when the airplane is not flown.

The minimum recommended operating frequency for the engine is one continuous flight hour (not counting taxi, takeoff and landing time) with oil temperatures of 165°F to 200°F every 30 days or less (depending on location and storage conditions). Airplanes operated close to oceans, lakes, rivers and in humid regions are in greater need of engine preservation than airplanes operated in arid regions. Appropriate engine preservation procedures must be practiced by the owner or operator of the airplane based on present environmental conditions and the frequency of airplane activity.

NOTE

The engine manufacturer does not recommend pulling the engine through by hand during storage periods.

(Continued Next Page)

GROUND HANDLING (Continued)

FLYABLE STORAGE (Continued)

If the airplane is to remain inactive for more than 30 days, consult the latest revision of Textron Lycoming Service Letter L180 (www.lycoming.textron.com).

It is recommended when storing the airplane for any period of time to keep fuel tanks full to minimize condensation in tanks. Keep the battery fully charged to prevent the electrolyte from freezing in cold weather. Refer to the Maintenance Manual for proper airplane storage procedures.

SERVICING

In addition to the Preflight Inspection covered in Section 4 of this POH, complete servicing, inspection and test requirements for your airplane are detailed in the Maintenance Manual. The Maintenance Manual outlines all items which require attention at specific intervals plus those items which require servicing, inspection, and/or testing at special intervals.

Since Cessna Service Stations conduct all service, inspection, and test procedures in accordance with applicable Maintenance Manuals, it is recommended that you contact a Cessna Service Station concerning these requirements and begin scheduling your airplane for service at the recommended intervals.

Cessna Progressive Care ensures that these requirements are accomplished at the required intervals to comply with the 100 hour or annual inspection as previously covered.

Depending on various flight operations, your local government aviation agency may require additional service, inspections, or tests. For these regulatory requirements, owners should check with local aviation officials where the airplane is being operated.

For quick and ready reference, quantities, materials and specifications for frequently used service items are as follows.

OIL

OIL SPECIFICATION

MIL-L-6082 or SAE J1966 Aviation Grade Straight Mineral Oil: Used when the airplane was delivered from the factory and should be used to replenish the supply during the first 25 hours. This oil should be drained and the filter changed after the first 25 hours of operation. Refill the engine with MIL-L-6082 or SAE J1966 Aviation Grade Straight Mineral Oil and continue to use until a total of 50 hours has accumulated or oil consumption has stabilized.

MIL-L-22851 or SAE J1899 Aviation Grade Ashless Dispersant Oil: Oil conforming to Textron Lycoming Service Instruction No 1014, and all revisions and supplements thereto, **must be used** after first 50 hours or oil consumption has stabilized.

RECOMMENDED VISCOSITY FOR TEMPERATURE RANGE

Multiviscosity or straight grade oil may be used throughout the year for engine lubrication. Refer to the following table for temperature versus viscosity ranges.

Temperature	MIL-L-6082 or SAE J1966 Straight Mineral Oil SAE Grade	MIL-L-22851 or SAE J1899 Ashless Dispersant Oil SAE Grade
Above 27°C (80°F)	60	60
Above 16°C (60°F)	50	40 or 50
-1°C (30°F) to 32°C (90°F)	40	40
-18°C (0°F) to 21°C (70°F)	30	30, 40 or 20W-40
Below -12°C (10°F)	20	30 or 20W-30
-18°C (0°F) to 32°C (90°F)	20W-50	20W-50 or 15W-50
All Temperatures	---	15W-50 or 20W-50

NOTE

When operating temperatures overlap, use the lighter grade of oil.

(Continued Next Page)

OIL (Continued)

CAPACITY OF ENGINE SUMP

The engine has a total capacity of 9 quarts, with the oil filter accounting for approximately one quart of that total. The engine oil sump has a capacity of 8 quarts. The engine must not be operated on less than 4 quarts (as measured by the dipstick). For extended flights, the engine should be filled to capacity.

OIL AND OIL FILTER CHANGE

After the first 25 hours of operation, drain the engine oil sump and replace the filter. Refill sump with straight mineral oil and use until a total of 50 hours has accumulated or oil consumption has stabilized; then change to ashless dispersant oil. Ashless dispersant oil (and oil filter) should be changed at time intervals set forth by the engine manufacturer.

NOTE

During the first 25 hour oil and filter change, a general inspection of the overall engine compartment is required. Items which are not normally checked during a preflight inspection should be given special attention. Hoses, metal lines and fittings should be inspected for signs of oil and fuel leaks, and checked for abrasions, chafing, security, proper routing and support, and evidence of deterioration. Inspect the intake and exhaust systems for cracks, evidence of leakage, and security of attachment. Engine controls and linkages should be checked for freedom of movement through their full range, security of attachment and evidence of wear. Inspect wiring for security, chafing, burning, defective insulation, loose or broken terminals, heat deterioration, and corroded terminals. Check the alternator belt in accordance with Maintenance Manual instructions, and retighten if necessary. A periodic check of these items during subsequent servicing operations is recommended.

FUEL

APPROVED FUEL GRADES (AND COLORS)

- 100LL Grade Aviation Fuel (Blue)
- 100 Grade Aviation Fuel (Green)

NOTE

Isopropyl alcohol or Diethylene Glycol Monomethyl Ether (DiEGME) may be added to the fuel supply in quantities not to exceed 1% (alcohol) or 0.15% (DiEGME) of total volume. Refer to Fuel Additives in later paragraphs for additional information.

FUEL CAPACITY

92.0 U.S. Gallons Total: 46.0 U.S. Gallons per tank.

NOTE

- To ensure maximum fuel capacity when refueling and minimize crossfeeding, the fuel selector valve should be placed in either the LEFT or RIGHT position and the airplane parked in a wings level, normal ground attitude. Refer to Figure 1-1 for a definition of normal ground attitude.
- Service the fuel system after each flight, and keep fuel tanks full to minimize condensation in the tanks.

(Continued Next Page)

FUEL (Continued)

FUEL ADDITIVES

Strict adherence to recommended preflight draining instructions as called for in Section 4 will eliminate any free water accumulations from the tank sumps. While small amounts of water may still remain in solution in the gasoline, it will normally be consumed and go unnoticed in the operation of the engine.

One exception to this can be encountered when operating under the combined effect of: (1) use of certain fuels, with (2) high humidity conditions on the ground (3) followed by flight at high altitude and low temperature. Under these unusual conditions, small amounts of water in solution can precipitate from the fuel stream and freeze in sufficient quantities to induce partial icing of the engine fuel system.

While these conditions are quite rare and will not normally pose a problem to owners and operators, they do exist in certain areas of the world and consequently must be dealt with, when encountered.

Therefore, to help alleviate the possibility of fuel icing occurring under these unusual conditions, it is permissible to add isopropyl alcohol or Diethylene Glycol Monomethyl Ether (DiEGME) compound to the fuel supply.

The introduction of alcohol or DiEGME compound into the fuel provides two distinct effects: (1) it absorbs the dissolved water from the gasoline and (2) alcohol has a freezing temperature depressant effect.

NOTE

When using fuel additives, it must be remembered that the final goal is to obtain a correct fuel to additive ratio in the tank, and not just with fuel coming out of the refueling nozzle. For example, adding 15 gallons of correctly proportioned fuel to a tank which contains 20 gallons of untreated fuel will result in a lower than acceptable concentration level to the 35 gallons of fuel which now reside in the tank.

(Continued Next Page)

FUEL (Continued)

FUEL ADDITIVES (Continued)

Alcohol, if used, is to be blended with the fuel in a concentration of 1% by volume. Concentrations greater than 1% are not recommended since they can be detrimental to fuel tank materials.

The manner in which the alcohol is added to the fuel is significant because alcohol is most effective when it is completely dissolved in the fuel. To ensure proper mixing, the following is recommended:

1. For best results, the alcohol should be added during the fueling operation by pouring the alcohol directly on the fuel stream issuing from the fueling nozzle.
2. An alternate method that may be used is to premix the complete alcohol dosage with some fuel in a separate clean container (approximately 2-3 gallon capacity) and then transferring this mixture to the tank prior to the fuel operation.

(Continued Next Page)

FUEL MIXING RATIO

B3118

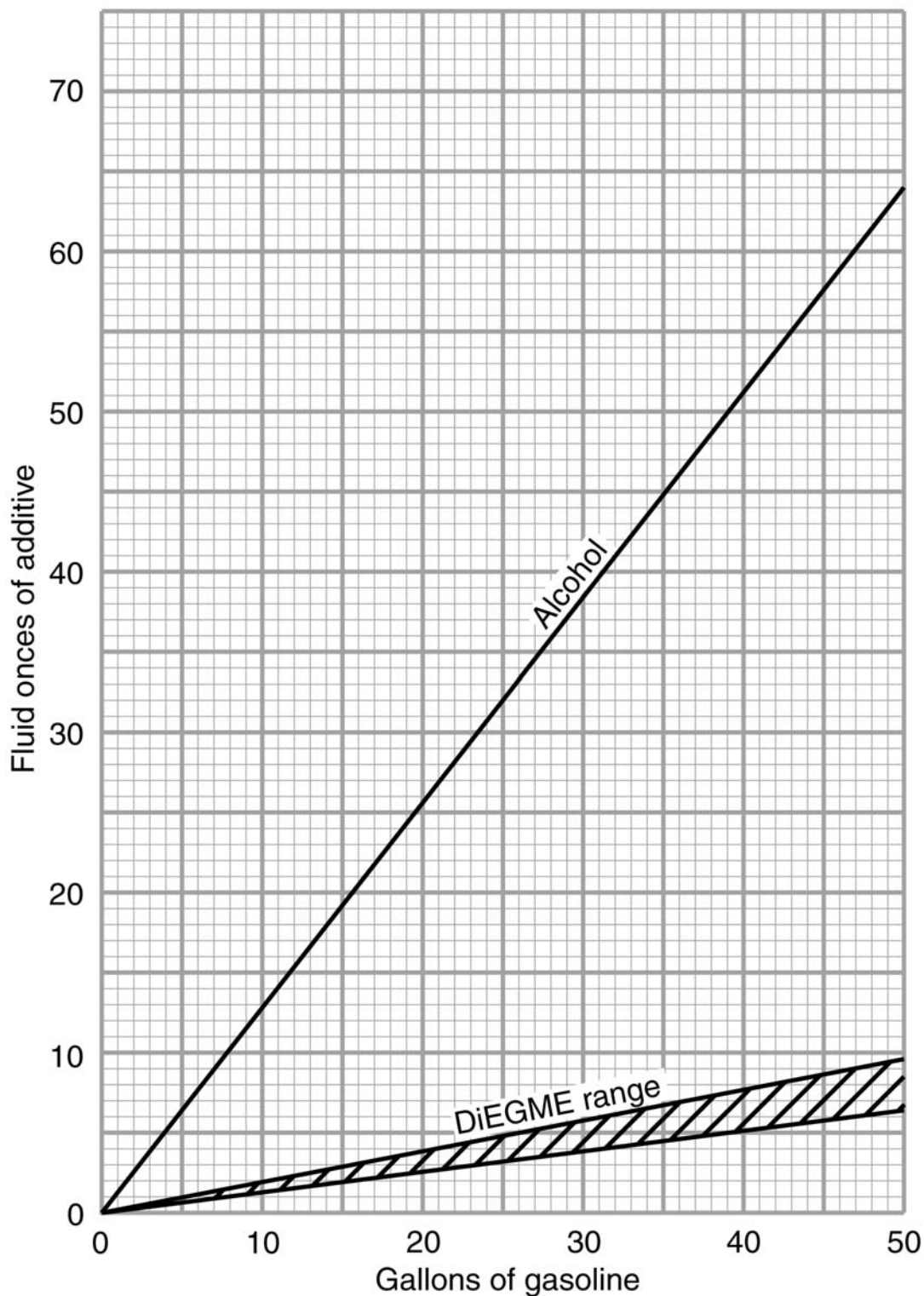

0585T1001

Figure 8-1

FUEL (Continued)

FUEL ADDITIVES (Continued)

Diethylene Glycol Monomethyl Ether (DiEGME) compound must be carefully mixed with the fuel in concentrations between 0.10% (minimum) and 0.15% (maximum) of total fuel volume. Refer to Figure 8-1 for a DiEGME-to-fuel mixing chart.

WARNING

ANTI-ICING ADDITIVE IS DANGEROUS TO HEALTH WHEN BREATHED AND/OR ABSORBED INTO THE SKIN.

CAUTION

MIXING OF DIEGME WITH FUEL IS EXTREMELY IMPORTANT. A CONCENTRATION IN EXCESS OF THAT RECOMMENDED (0.15% BY VOLUME MAXIMUM) MAY RESULT IN DETRIMENTAL EFFECTS TO THE FUEL TANK AND SEALANT, AND DAMAGE TO O-RINGS AND SEALS USED IN THE FUEL SYSTEM AND ENGINE COMPONENTS. A CONCENTRATION OF LESS THAN THAT RECOMMENDED (0.10% BY TOTAL VOLUME MINIMUM) WILL RESULT IN INEFFECTIVE TREATMENT. USE ONLY BLENDING EQUIPMENT THAT IS RECOMMENDED BY THE MANUFACTURER TO OBTAIN PROPER PROPORTIONING.

Prolonged storage of the airplane will result in a water buildup in the fuel which leeches out the additive. An indication of this is when an excessive amount of water accumulates in the fuel tank sumps. The concentration can be checked using a differential refractometer. It is imperative that the technical manual for the differential refractometer be followed explicitly when checking the additive concentration.

(Continued Next Page)

FUEL (Continued)

FUEL CONTAMINATION

Fuel contamination is usually the result of foreign material present in the fuel system, and may consist of water, rust, sand, dirt, microbes or bacterial growth. In addition, additives that are not compatible with fuel or fuel system components can cause the fuel to become contaminated.

Before each flight and after each refueling, use a clear sampler cup and drain at least a cupful of fuel from each fuel tank drain location and from the fuel strainer quick drain valve to determine if contaminants are present, and to ensure the airplane has been fueled with the proper grade of fuel.

If contamination is detected, drain **all** fuel drain points again, including the fuel selector drain valve, and then gently rock the wings and lower the tail to the ground to move any additional contaminants to the sampling points. Take repeated samples from all fuel drain points until **all** contamination has been removed. If, after repeated sampling, evidence of contamination still exists, the airplane should not be flown. Tanks should be drained and system purged by qualified maintenance personnel. All evidence of contamination must be removed before further flight. If the airplane has been serviced with the improper fuel grade, defuel completely and refuel with the correct grade. Do not fly the airplane with contaminated or unapproved fuel.

In addition, Owners/Operators who are not acquainted with a particular fixed base operator should be assured that the fuel supply has been checked for contamination and is properly filtered before allowing the airplane to be serviced. Fuel tanks should be kept full between flights, provided weight and balance considerations will permit, to reduce the possibility of water condensing on the walls of partially filled tanks.

To further reduce the possibility of contaminated fuel, routine maintenance of the fuel system should be performed in accordance with the airplane Maintenance Manual. Only the proper fuel, as recommended in this POH, should be used, and fuel additives should not be used unless approved by Cessna and the Federal Aviation Administration.

LANDING GEAR

Consult the following table for servicing information on the landing gear.

COMPONENT	SERVICING CRITERIA
Nose Wheel (5.00-5, 6-Ply Rated Tire)	49.0 PSI
Main Wheel (6.00-6, 6-Ply Rated Tire)	42.0 PSI
Brakes	MIL-H-5606
Nose Gear Shock Strut	MIL-H-5606; 55.0-60.0 PSI *

- * Keep strut filled with MIL-H-5606 hydraulic fluid per filling instructions placard, and with no load on the strut, inflate with air to 55.0-60.0 PSI. Do not over inflate.

CLEANING AND CARE

WINDSHIELD AND WINDOWS

The plastic windshield and windows should be cleaned with an airplane windshield cleaner. Apply the cleaner sparingly with soft cloths, and rub with moderate pressure until all dirt, oil scum and bug stains are removed. Allow the cleaner to dry, then wipe it off with soft flannel cloths.

CAUTION

NEVER USE GASOLINE, BENZENE, ALCOHOL, ACETONE, FIRE EXTINGUISHER, ANTI-ICE FLUID, LACQUER THINNER OR GLASS CLEANER TO CLEAN THE PLASTIC. THESE MATERIALS WILL ATTACK THE PLASTIC AND MAY CAUSE IT TO CRAZE.

If a windshield cleaner is not available, the plastic can be cleaned with soft cloths moistened with Stoddard solvent to remove oil and grease. Follow by carefully washing with a mild detergent and plenty of water. Rinse thoroughly, then dry with a clean moist chamois.

Do not rub the plastic with a dry cloth since this builds up an electrostatic charge which attracts dust. Waxing with a good commercial wax will finish the cleaning job. A thin, even coat of wax, polished out by hand with clean soft flannel cloths, will fill in minor scratches and help prevent further scratching.

Do not use a canvas cover on the windshield unless freezing rain or sleet is anticipated since the cover may scratch the plastic surface.

(Continued Next Page)

CLEANING AND CARE (Continued)

PAINTED SURFACES

The painted exterior surfaces of your new Cessna have a durable, long lasting finish.

Generally, the painted surfaces can be kept bright by washing with water and mild soap, followed by a rinse with water and drying with cloths or a chamois. Harsh or abrasive soaps or detergents which cause corrosion or scratches should never be used. Remove stubborn oil and grease with a cloth moistened with Stoddard solvent. Take special care to make sure that the exterior graphics are not touched by the solvent. For complete care of exterior graphics, refer to the Maintenance Manual.

To seal any minor surface chips or scratches and protect against corrosion, the airplane should be waxed regularly with a good automotive wax applied in accordance with the manufacturer's instructions. If the airplane is operated in a seacoast or other salt water environment, it must be washed and waxed more frequently to assure adequate protection. Special care should be taken to seal around rivet heads and skin laps, which are the areas most susceptible to corrosion. A heavier coating of wax on the leading edges of the wings and tail and on the cowl nose cap and propeller spinner will help reduce the abrasion encountered in these areas. Reapplication of wax will generally be necessary after cleaning with soap solution or after chemical deicing operations.

When the airplane is parked outside in cold climates and it is necessary to remove ice before flight, care should be taken to protect the painted surfaces during ice removal with chemical liquids. Isopropyl alcohol will satisfactorily remove ice accumulations without damaging the paint. However, keep the isopropyl alcohol away from the windshield and cabin windows since it will attack the plastic and may cause it to craze.

(Continued Next Page)

CLEANING AND CARE (Continued)

PROPELLER CARE

Preflight inspection of propeller blades for nicks, and wiping them occasionally with an oily cloth to clean off grass and bug stains will assure long blade life. Small nicks on the propeller, particularly near the tips and on the leading edges, should be dressed out as soon as possible since these nicks produce stress concentrations, and if ignored, may result in cracks or failure of the propeller blade. Never use an alkaline cleaner on the blades; remove grease and dirt with Stoddard solvent.

ENGINE CARE

The engine may be cleaned, using a suitable solvent, in accordance with instructions in the airplane Maintenance Manual. Most efficient cleaning is done using a spray type cleaner. Before spray cleaning, ensure that protection is afforded for components which might be adversely affected by the solvent. Refer to the airplane Maintenance Manual for proper lubrication of controls and components after engine cleaning. The induction air filter should be replaced when its condition warrants, not to exceed 500 hours.

(Continued Next Page)

CLEANING AND CARE (Continued)

INTERIOR CARE

To remove dust and loose dirt from the upholstery and carpet, clean the interior regularly with a vacuum cleaner.

Blot up any spilled liquid promptly with cleansing tissue or rags. Don't pat the spot; press the blotting material firmly and hold it for several seconds. Continue blotting until no more liquid is taken up. Scrape off sticky materials with a dull knife, then spot clean the area.

Oily spots may be cleaned with household spot removers, used sparingly. Before using any solvent, read the instructions on the container and test it on an obscure place on the fabric to be cleaned. Never saturate the fabric with a volatile solvent; it may damage the padding and backing materials.

Soiled upholstery and carpet may be cleaned with foam type detergent, used according to the manufacturer's instructions. To minimize wetting the fabric, keep the foam as dry as possible and remove it with a vacuum cleaner.

For complete information related to interior cleaning, refer to the Maintenance Manual.

AVIONICS CARE

The Garmin GDU displays have an anti-reflective coating that is very sensitive to skin oils, waxes, ammonia, and abrasive cleaners. Clean the displays as described in the G1000 Cockpit Reference Guide.

SUPPLEMENTS

INTRODUCTION

The supplements in this section contain amended operating limitations, operating procedures, performance data and other necessary information for airplanes conducting special operations for both standard and optional equipment installed in the airplane. Operators should refer to each supplement to ensure that all limitations and procedures appropriate for their airplane are observed.

A non FAA Approved Log Of Approved Supplements is provided for convenience only. This log is a numerical list of all FAA Approved supplements applicable to this airplane by name, supplement number and revision level. This log should be used as a checklist to ensure all applicable supplements have been placed in the Pilot's Operating Handbook (POH). Supplements for both standard and installed optional equipment must be maintained to the latest revision. Those supplements applicable to optional equipment which is not installed in the airplane, do not have to be retained.

Each individual supplement contains its own Log of Effective Pages. This log lists the page number and revision level of every page in the supplement. The log also lists the dates on which revisions to the supplement occurred. Supplement page numbers will include an S and the supplement number preceding the page number.

The part number of the supplement provides information on the revision level. Refer to the following example:

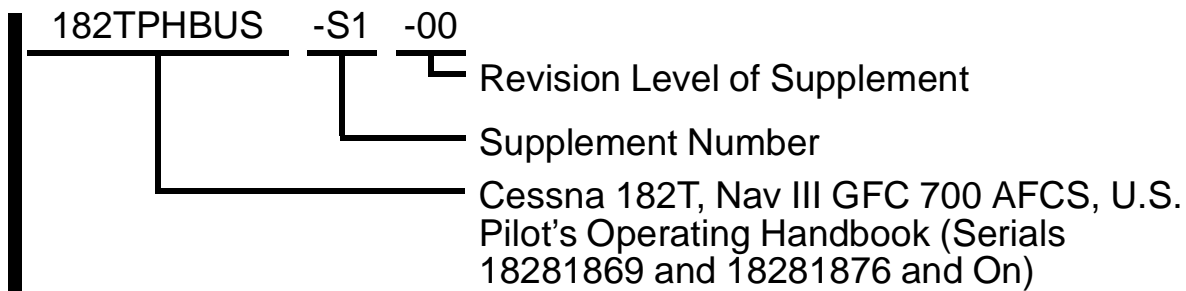

LOG OF APPROVED SUPPLEMENTS

NOTE

IT IS THE AIRPLANE OWNER'S RESPONSIBILITY TO MAKE SURE THAT HE OR SHE HAS THE LATEST REVISION TO EACH SUPPLEMENT OF A PILOT'S OPERATING HANDBOOK, AND THE LATEST ISSUED "LOG OF APPROVED SUPPLEMENTS". THIS "LOG OF APPROVED SUPPLEMENTS" WAS THE LATEST VERSION AS OF THE DATE IT WAS SHIPPED BY CESSNA; HOWEVER, SOME CHANGES MAY HAVE OCCURRED, AND THE OWNER SHOULD VERIFY THIS IS THE LATEST, MOST UP-TO-DATE VERSION BY CONTACTING CESSNA CUSTOMER SUPPORT AT (316) 517-5800.

Supplement Number	Name	Revision Level	Equipment Installed
1	Artex ME406 Emergency Locator Transmitter (ELT)	0	_____
2	Artex C406-N Emergency Locator Transmitter (ELT)	0	_____
3	L3 Communications WX-500 Stormscope	0	_____
4	Bendix/King KR87 Automatic Direction Finder (ADF)	0	_____
5	Winterization Kit	0	_____
6	JAR-OPS Operational Eligibility	0	_____
7	Canadian Certified Airplanes	0	_____
8	Brazilian Certified Airplanes	0	_____

Pilot's Operating Handbook And FAA Approved Airplane Flight Manual **SKYLANE**

CESSNA MODEL 182T

NAV III AVIONICS OPTION - GFC 700 AFCS

Serials 18281869 and 18281876 and On

SUPPLEMENT 1

ARTEX ME406

EMERGENCY LOCATOR TRANSMITTER (ELT)

SERIAL NO. _____
REGISTRATION NO. _____

This supplement must be inserted into Section 9 of the Pilot's Operating Handbook and FAA Approved Airplane Flight Manual when the Artex ME406 Emergency Locator Transmitter (ELT) is installed.

APPROVED BY

FAA APPROVED UNDER 14 CFR PART 21 SUBPART J
Cessna Aircraft Co.
Delegation Option Authorization DOA-230584-CE

Administrative AR
RLS



Member of GAMA

DATE OF APPROVAL 02 November 2006

2 NOVEMBER 2006

COPYRIGHT © 2006
CESSNA AIRCRAFT COMPANY
WICHITA, KANSAS, USA

SUPPLEMENT 1

ARTEX ME406 EMERGENCY LOCATOR TRANSMITTER (ELT)

Use the Log of Effective Pages to determine the current status of this supplement.

Pages affected by the current revision are indicated by an asterisk (*) preceding the page number.

<u>Supplement Status</u>	<u>Date</u>
Original Issue	2 November 2006

LOG OF EFFECTIVE PAGES

Page Number	Page Status	Revision Number
S1-1 thru S1-8	Original	0

SERVICE BULLETIN CONFIGURATION LIST

The following is a list of Service Bulletins that are applicable to the operation of the airplane, and have been incorporated into this supplement. This list contains only those Service Bulletins that are currently active.

<u>Number</u>	<u>Title</u>	<u>Airplane Serial</u>	<u>Revision</u>	<u>Incorporated</u>
		<u>Effectivity</u>	<u>Incorporated</u>	<u>in Airplane</u>

ARTEX ME406 EMERGENCY LOCATOR TRANSMITTER (ELT)

GENERAL

The Artex ME406 Emergency Locator Transmitter (ELT) installation uses a solid-state 2-frequency transmitter powered by an internal lithium battery. The ME406 is also equipped with an instrument panel-mounted remote switch assembly, that includes a red warning light, and an external antenna mounted on the top of the tailcone. The remote switch assembly is installed along the upper right instrument panel and controls ELT operating modes from the flight crew station. When the remote switch is set to the ARM position, the transmitter is energized only when the internal "G" switch senses longitudinal inertia forces per TSO-C91a/TSO-C126. When the remote switch is set to the ON position, the transmitter is immediately energized.

The ME406 transmitter unit is located in the tailcone along the left side behind the baggage compartment aft panel. On the ELT transmitter unit is a panel containing an ARM/ON switch and a transmitter warning light.

The ELT installation uses two different warnings to tell the pilot when the ELT is energized. The aural warning is an unusual sound that is easily heard by the pilot. The visual warning is a flashing red light directly above the remote switch that shows the pilot that the ELT has been activated.

When the ME406 is energized, the ELT transmits the standard swept tone signal on the international VHF frequency of 121.5 MHz until battery power is gone. The 121.5 MHz signal is mainly used to pinpoint the beacon during search and rescue operations, and is monitored by general aviation, commercial aircraft, and government agencies.

In addition, for the first 24 hours of the ELT being energized, a 406.028 MHz signal is transmitted at 50 second intervals. This transmission lasts 440 milliseconds and contains identification data programmed into the ELT and is received by COSPAS/SARSAT satellites. The transmitted data may include the Aircraft ID, ELT Serial Number, Country Code, and COSPAS/SARSAT ID.

(Continued Next Page)

ARTEX ME406 ELT CONTROL PANEL

B6521

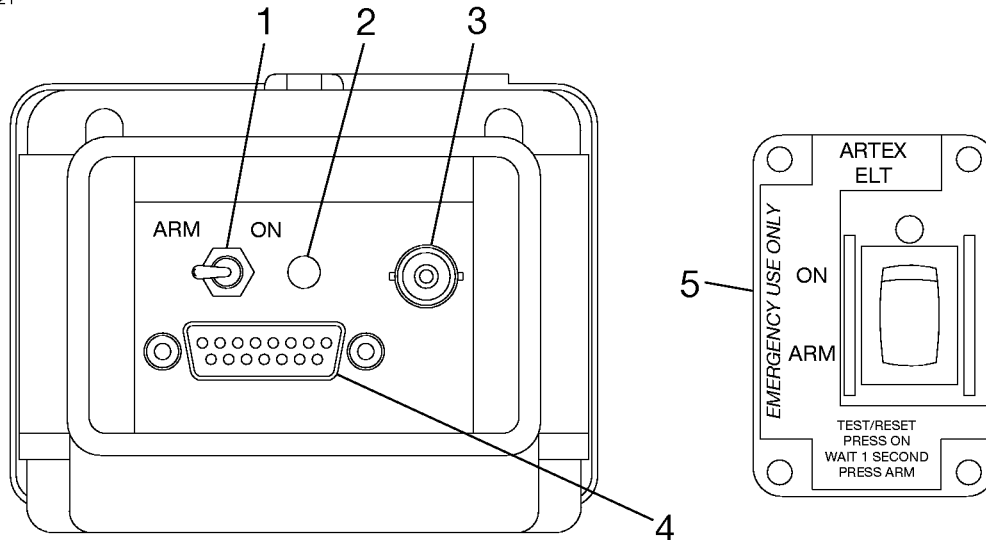

0718T1107

1. ELT PANEL SWITCH (2-Position Toggle Switch):
 - a. ARM (OFF) - Turns OFF and ARMS transmitter for automatic activation if "G" switch senses a predetermined deceleration level.
 - b. ON - Activates transmitter instantly. The ON position bypasses the automatic activation switch. The RED warning light on ELT panel and on the remote switch assembly mounted on the instrument panel should come on.
2. TRANSMITTER WARNING LIGHT - Light comes on RED to indicate the transmitter is transmitting a distress signal.
3. ANTENNA RECEPTACLE - Connects to the antenna mounted on top of tailcone.
4. REMOTE CABLE JACK - Connects to the ELT remote switch assembly located on the upper right instrument panel.
5. REMOTE SWITCH ASSEMBLY - (2-Position Rocker Switch):
 - a. ARM (OFF) - Turns OFF and ARMS transmitter for automatic activation if "G" switch senses a predetermined deceleration level.
 - b. ON - Remotely activates the transmitter for test or emergency situations. The RED warning light above the rocker switch comes on to indicate that the transmitter is transmitting a distress signal.

Figure S1-1

OPERATING LIMITATIONS

There are no additional airplane operating limitations when the Artex ME406 ELT is installed.

The airplane owner or operator must register the ME406 ELT with the applicable civil aviation authority before use to make sure that the identification code transmitted by the ELT is in the COSPAS/SARSAT database. Refer to www.cospas-sarsat.org for registration information.

Refer to 14 CFR 91.207 for ELT inspection requirements. The ME406 must be inspected and tested by an approved technician using the correct test equipment under the appropriate civil aviation authorities approved conditions.

EMERGENCY PROCEDURES

If a forced landing is necessary, set the remote switch to the ON position before landing. This is very important in remote or mountainous terrain. The red warning light above the remote switch will flash and the aural warning will be heard.

After a landing when search and rescue aid is needed, use the ELT as follows:

NOTE

The ELT remote switch assembly could be inoperative if damaged during a forced landing. If inoperative, the inertia "G" switch will activate automatically. However, to turn the ELT OFF and ON again requires manual switching of the ELT panel switch which is located on the ELT unit.

1. MAKE SURE THE ELT IS ENERGIZED:
 - a. If the red warning light above the remote switch is not flashing, set the remote switch to the ON position.
 - b. Listen for the aural warning. If the COM radio(s) operate and can be energized safely (no threat of fire or explosion), energize a COM radio and set the frequency to 121.5 MHz. The ELT tone should be heard on the COM radio if the ELT is working correctly. When done, de-energize the COM radio(s) to conserve the airplane battery power.
 - c. Make sure that nothing is touching or blocking the ELT antenna.
2. AFTER RESCUE - Set the remote switch to the ARM position to de-energize the ELT. If the remote switch does not function, set the switch on the ME406 (in the tailcone) to the ARM position.

NORMAL PROCEDURES

When operating in a remote area or over hazardous terrain, it is recommended that the ELT be inspected by an approved technician more frequently than required by 14 CFR 91.207.

NORMAL OPERATION

1. Check that the remote switch (on the upper right instrument panel) is set to the ARM position.

Normal operation of the ME406 from the flight crew station is only to de-energize and arm the ELT after it has been accidentally energized (no emergency).

The ELT can be energized by a lightning strike or hard landing. If the red light above the remote switch is flashing and the aural warning is heard, the ELT is energized. Check for the emergency signal on a COM radio set to 121.5 MHz. To stop the transmissions, set the remote switch to the ON position momentarily and then set to the ARM position. Tell the nearest Air Traffic Control facility about the accidental transmissions as soon as possible to hold search and rescue work to a minimum.

PERFORMANCE

There is no change to the airplane performance when the Artex ME406 ELT is installed.

Pilot's Operating Handbook And FAA Approved Airplane Flight Manual **SKYLANE**

CESSNA MODEL 182T

NAV III AVIONICS OPTION - GFC 700 AFCS

Serials 18281869 and 18281876 and On

SUPPLEMENT 2

ARTEX C406-N

EMERGENCY LOCATOR TRANSMITTER (ELT)

SERIAL NO. _____
REGISTRATION NO. _____

This supplement must be inserted into Section 9 of the Pilot's Operating Handbook and FAA Approved Airplane Flight Manual when the Artex C406-N Emergency Locator Transmitter (ELT) is installed.

APPROVED BY

FAA APPROVED UNDER 14 CFR PART 21 SUBPART J
Cessna Aircraft Co.
Delegation Option Authorization DOA-230584-CE

Administrative AR
RLS



Member of GAMA

DATE OF APPROVAL 02 November 2006

2 NOVEMBER 2006

COPYRIGHT © 2006
CESSNA AIRCRAFT COMPANY
WICHITA, KANSAS, USA

182TPHBUS-S2-00

U.S.

S2-1

SUPPLEMENT 2

ARTEX C406-N EMERGENCY LOCATOR TRANSMITTER (ELT)

Use the Log of Effective Pages to determine the current status of this supplement.

Pages affected by the current revision are indicated by an asterisk (*) preceding the page number.

Supplement Status

Original Issue

Date

2 November 2006

LOG OF EFFECTIVE PAGES

Page Number	Page Status	Revision Number
S2-1 thru S2-8	Original	0

SERVICE BULLETIN CONFIGURATION LIST

The following is a list of Service Bulletins that are applicable to the operation of the airplane, and have been incorporated into this supplement. This list contains only those Service Bulletins that are currently active.

<u>Number</u>	<u>Title</u>	<u>Airplane Serial</u>	<u>Revision</u>	<u>Incorporated</u>
		<u>Effectivity</u>	<u>Incorporated</u>	<u>in Airplane</u>

ARTEX C406-N EMERGENCY LOCATOR TRANSMITTER (ELT)

GENERAL

The Artex C406-N Emergency Locator Transmitter (ELT) installation uses a solid-state 3-frequency transmitter powered by an internal lithium battery. The navigation function of the C406-N ELT receives power from the airplane's main battery thru Avionics Bus 1 and the Essential Bus. The C406-N is also equipped with an instrument panel-mounted remote switch assembly, that includes a red warning light, and an external antenna mounted on the top of the tailcone. The remote switch assembly is installed along the top right side of the instrument panel and controls ELT operating modes from the flight crew station. When the remote switch is set to the ARM position, the transmitter is energized only when the internal "G-switch" senses longitudinal inertia forces per TSO-C91a/TSO-C126. When the remote switch is set to the ON position, the transmitter is immediately energized.

The C406-N transmitter unit is located in the tailcone along the left side behind the baggage compartment aft panel. On the ELT transmitter unit is a panel containing an ON/OFF switch and a transmitter warning light.

The ELT installation uses two different warnings to tell the pilot when the ELT is energized. The aural warning is an unusual sound that is easily heard by the pilot. The visual warning is a flashing red light directly above the remote switch that shows the pilot that the ELT has been activated.

When the C406-N is energized, the ELT transmits the standard swept tone signal on the international VHF frequency of 121.5 MHz and UHF frequency of 243.0 MHz until battery power is gone. The 121.5 MHz signal is mainly used to pinpoint the beacon during search and rescue operations, and is monitored by general aviation, commercial aircraft, and government agencies.

In addition, for the first 24 hours of the ELT being energized, a 406.028 MHz signal is transmitted at 50 second intervals. This transmission lasts 440 milliseconds and contains identification data programmed into the ELT and is received by COSPAS/SARSAT satellites. The transmitted data may include the Aircraft ID, GPS coordinates, ELT Serial Number, Country Code, and COSPAS/SARSAT ID.

(Continued Next Page)

ARTEX C406-N ELT CONTROL PANEL

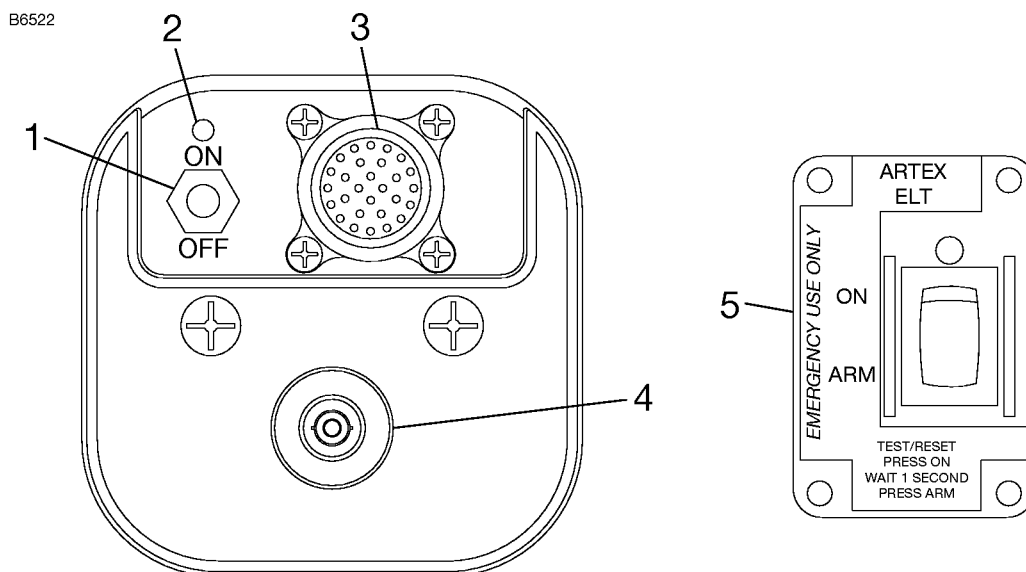

0718T1106

1. ELT PANEL SWITCH (2-Position Toggle Switch):
 - a. OFF - Turns OFF and ARMS transmitter for automatic activation if “G” switch senses a predetermined deceleration level.
 - b. ON - Activates transmitter instantly. The ON position bypasses the automatic activation switch. The RED warning light on ELT panel and on the remote switch assembly mounted on the instrument panel should come on.
2. TRANSMITTER WARNING LIGHT - Light comes on RED to indicate the transmitter is transmitting a distress signal.
3. REMOTE CABLE JACK - Connects to the ELT remote switch assembly located on the upper right instrument panel.
4. ANTENNA RECEPTACLE - Connects to the antenna mounted on top of tailcone.
5. REMOTE SWITCH ASSEMBLY - (2-Position Rocker Switch):
 - a. ARM (OFF) - Turns OFF and ARMS transmitter for automatic activation if “G” switch senses a predetermined deceleration level.
 - b. ON - Remotely activates the transmitter for test or emergency situations. The RED warning light above the rocker switch comes on to indicate that the transmitter is transmitting a distress signal.

Figure S2-1

OPERATING LIMITATIONS

There are no additional airplane operating limitations when the Artex C406-N ELT is installed.

The airplane owner or operator must register the C406-N ELT with the applicable civil aviation authority before use to make sure that the identification code transmitted by the ELT is in the COSPAS/SARSAT database. Refer to www.cospas-sarsat.org for registration information.

Refer to 14 CFR 91.207 for ELT inspection requirements. The C406-N must be inspected and tested by an approved technician using the correct test equipment under the appropriate civil aviation authorities approved conditions.

EMERGENCY PROCEDURES

If a forced landing is necessary, set the remote switch to the ON position before landing. This is very important in remote or mountainous terrain. The red warning light above the remote switch will flash and the aural warning will be heard.

After a landing when search and rescue aid is needed, use the ELT as follows:

NOTE

The ELT remote switch assembly could be inoperative if damaged during a forced landing. If inoperative, the inertia "G" switch will activate automatically. However, to turn the ELT OFF and ON again requires manual switching of the ELT panel switch which is located on the ELT unit.

1. MAKE SURE THE ELT IS ENERGIZED:
 - a. If the red warning light above the remote switch is not flashing, set the remote switch to the ON position.
 - b. Listen for the aural warning. If the COM radio(s) operate and can be energized safely (no threat of fire or explosion), energize a COM radio and set the frequency to 121.5 MHz. The ELT tone should be heard on the COM radio if the ELT is working correctly. When done, de-energize the COM radio(s) to conserve the airplane battery power.
 - c. Make sure that nothing is touching or blocking the ELT antenna.
2. AFTER RESCUE - Set the remote switch to the ARM position to de-energize the ELT. If the remote switch does not function, set the switch on the C406-N (in the tailcone) to the OFF position.

NORMAL PROCEDURES

When operating in a remote area or over hazardous terrain, it is recommended that the ELT be inspected by an approved technician more frequently than required by 14 CFR 91.207.

NORMAL OPERATION

1. Check that the remote switch (on the right instrument panel) is set to the ARM position.

Normal operation of the C406-N from the flight crew station is only to de-energize and arm the ELT after it has been accidentally energized (no emergency).

The ELT can be energized by a lightning strike or hard landing. If the red light above the remote switch is flashing and the aural warning is heard, the ELT is energized. Check for the emergency signal on a COM radio set to 121.5 MHz. To stop the transmissions, set the remote switch to the ON position momentarily and then set to the ARM position. Tell the nearest Air Traffic Control facility about the accidental transmissions as soon as possible to hold search and rescue work to a minimum.

PERFORMANCE

There is no change to the airplane performance when the Artex C406-N ELT is installed.

Pilot's Operating Handbook And FAA Approved Airplane Flight Manual **SKYLANE**

CESSNA MODEL 182T

NAV III AVIONICS OPTION - GFC 700 AFCS

Serials 18281869 and 18281876 and On

SUPPLEMENT 3

L3 COMMUNICATIONS WX-500 STORMSCOPE

SERIAL NO. _____
REGISTRATION NO. _____

This supplement must be inserted into Section 9 of the Pilot's Operating Handbook and FAA Approved Airplane Flight Manual when the L3 Communications WX-500 Stormscope is installed.

APPROVED BY

FAA APPROVED UNDER 14 CFR PART 21 SUBPART J
Cessna Aircraft Co.
Delegation Option Authorization DOA-230584-CE

 Administrative AR



Member of GAMA

DATE OF APPROVAL 02 November 2006

2 NOVEMBER 2006

COPYRIGHT © 2006
CESSNA AIRCRAFT COMPANY
WICHITA, KANSAS, USA

SUPPLEMENT 3

L3 COMMUNICATIONS WX-500 STORMSCOPE

Use the Log of Effective Pages to determine the current status of this supplement.

Pages affected by the current revision are indicated by an asterisk (*) preceding the page number.

Supplement Status

Original Issue

Date

2 November 2006

LOG OF EFFECTIVE PAGES

Page Number	Page Status	Revision Number
S3-1 thru S3-6	Original	0

SERVICE BULLETIN CONFIGURATION LIST

The following is a list of Service Bulletins that are applicable to the operation of the airplane, and have been incorporated into this supplement. This list contains only those Service Bulletins that are currently active.

<u>Number</u>	<u>Title</u>	<u>Airplane Serial</u> <u>Effectivity</u>	<u>Revision</u> <u>Incorporated</u>	<u>Incorporated</u> <u>in Airplane</u>
---------------	--------------	--	--	---

L3 COMMUNICATIONS WX-500 STORMSCOPE

GENERAL

The L3 Communications WX-500 Stormscope Series II Weather Mapping Sensor is a "black-box" type weather sensor/processor that uses an external controller/display unit for control input and output display functions. In this airplane, the WX-500 is integrated with the Garmin G1000 Integrated Cockpit System Multifunction Display (MFD) for the control and display of all Stormscope functions. See the G1000 Cockpit Reference Guide for more information regarding operation of the G1000 MFD.

CAUTION

THE L3 COMMUNICATIONS WX-500 STORMSCOPE IS APPROVED FOR USE ONLY IN AVOIDING HAZARDOUS WEATHER (THUNDERSTORMS). USE OF THE WX-500 TO PENETRATE HAZARDOUS WEATHER IS PROHIBITED.

The L3 Communications WX-500 Stormscope sensor detects electrical discharge (lightning) activity through a dedicated antenna mounted on the bottom of the airplane. The Stormscope processor continuously acquires electrical discharge data and performs self-test functions to ensure that the data presented to the pilot is always current and reliable when displayed. The system is heading-stabilized, so that the proper orientation of displayed data relative to the airplane position during maneuvering is maintained.

The Stormscope maps electrical discharge activity at ranges up to 200 nautical miles (nm) and displays that activity map to the flight crew, either centered on the airplane position (360° view) or ahead of the airplane position through 60° on either side of the airplane heading (120° view).

(Continued Next Page)

GENERAL (Continued)

No dedicated external power control for the WX-500 Stormscope is provided. The WX-500 is powered through the AVIONICS BUS 1 switch and is current-protected by the STORM SCOPE circuit breaker. At startup, the WX-500 will perform self-tests and provide error messages, if necessary, through the G1000 Primary Flight Display (PFD) ALERTS window and MFD MAP-WEATHER MAP page. See the WX-500 User's Guide for recommended actions if an error message appears.

WX-500 weather data can be displayed on the MFD MAP-WEATHER MAP page or may be displayed (overlaid) on the MAP-NAVIGATION MAP page and/or the PFD INSET MAP display. From the MFD MAP-WEATHER MAP page, the user may select the desired view (360° or 120°) by pressing the VIEW softkey. The range (25 to 200 nautical miles) may be set by rotating the RNG control knob on the MFD bezel. The user may also choose between Strike or Cell display modes using the MODE softkey. See the WX-500 User's Guide for information regarding Strike and Cell mode display differences.

To overlay weather data on the MFD MAP-NAVIGATION MAP page, select the MAP softkey, then select the LTNG softkey and finally select the BACK softkey to return to the map. Availability will be shown by a lightning bolt icon in the lower right corner of the map page (grouped with icons for TRAFFIC, TOPO and TERRAIN, if selected ON). Lightning strikes will be depicted on the Map Mode display as yellow lightning bolts. The Stormscope display mode (Strike or Cell) will be as selected on the MAP-WEATHER MAP page. The view setting will be 120° ARC and the range setting will match the NAVIGATION MAP range selection to 200 nm.

NOTE

In evaluating lightning strike data, it may be useful to clear the accumulated strike points on the display from time to time and then monitoring the reappearance of strike activity on the cleared display.

OPERATING LIMITATIONS

The L3 Communications WX-500 Stormscope is approved only as an aid to hazardous weather (thunderstorm) avoidance. Use for hazardous weather penetration is prohibited.

The Honeywell Bendix/King KMD 550 Multi-Function Display Pilot's Guide must be available to the flight crew when operating the WX-500 Stormscope.

The WX-500 Stormscope Series II Weather Mapping Sensor User's Guide must be available to the flight crew when operating the WX-500 Stormscope.

EMERGENCY PROCEDURES

There is no change to the airplane emergency procedures when the L3 Communications WX-500 Stormscope is installed.

NORMAL PROCEDURES

Static discharge from the static wicks on the tail may cause false indications of lightning strikes at the 6 o'clock position with the 200 nm range selected.

Refer to the WX-500 User's Guide under "Error Message Recommended Actions" for discontinuing use of the Stormscope if a Stormscope error message appears.

PERFORMANCE

There is no change to the airplane performance when the L3 Communications WX-500 Stormscope is installed.

Pilot's Operating Handbook And FAA Approved Airplane Flight Manual **SKYLANE**

CESSNA MODEL 182T
NAV III AVIONICS OPTION - GFC 700 AFCS
Serials 18281869 and 18281876 and On

SUPPLEMENT 4
BENDIX/KING KR87
AUTOMATIC DIRECTION FINDER (ADF)

SERIAL NO. _____
REGISTRATION NO. _____

This supplement must be inserted into Section 9 of the Pilot's Operating Handbook and FAA Approved Airplane Flight Manual when the Bendix/King KR 87 Automatic Direction Finder (ADF) is installed.

APPROVED BY

FAA APPROVED UNDER 14 CFR PART 21 SUBPART J
Cessna Aircraft Co.
Delegation Option Authorization DOA-230584-CE

Administrative AR



Member of GAMA

DATE OF APPROVAL 02 November 2006

2 NOVEMBER 2006

COPYRIGHT © 2006
CESSNA AIRCRAFT COMPANY
WICHITA, KANSAS, USA

SUPPLEMENT 4

BENDIX/KING KR87 AUTOMATIC DIRECTION FINDER (ADF)

Use the Log of Effective Pages to determine the current status of this supplement.

Pages affected by the current revision are indicated by an asterisk (*) preceding the page number.

Supplement Status

Original Issue

Date

2 November 2006

LOG OF EFFECTIVE PAGES

Page Number	Page Status	Revision Number
S4-1 thru S4-12	Original	0

SERVICE BULLETIN CONFIGURATION LIST

The following is a list of Service Bulletins that are applicable to the operation of the airplane, and have been incorporated into this supplement. This list contains only those Service Bulletins that are currently active.

<u>Number</u>	<u>Title</u>	<u>Airplane Serial</u> <u>Effectivity</u>	<u>Revision</u> <u>Incorporated</u>	<u>Incorporated</u> <u>in Airplane</u>
---------------	--------------	--	--	---

BENDIX/KING KR87 AUTOMATIC DIRECTION FINDER (ADF)

GENERAL

The Bendix/King Digital ADF is a panel-mounted, digitally tuned automatic direction finder. It is designed to provide continuous 1-kHz digital tuning in the frequency range of 200-kHz to 1799-kHz and eliminates the need for mechanical band switching. The system has a receiver, a built-in electronic timer, a bearing pointer shown on the G1000 Horizontal Situation Indicator (HSI), and a KA-44B combined loop and sense antenna. Controls and displays for the Bendix/King Digital ADF are shown and described in Figure S4-1. The Garmin GMA 1347 Audio Panel is used to control audio output. Audio panel operation is described in the Garmin G1000 Cockpit Reference Guide.

The Bendix/King Digital ADF can be used for position plotting and homing procedures, and for aural reception of amplitude modulated (AM) signals.

The flip-flop frequency display allows switching between preselected standby and active frequencies by pushing the frequency transfer button. Both preselected frequencies are stored in a nonvolatile memory circuit (no battery power required) and displayed in large, easy-to-read, self-dimming gas discharge numbers. The active frequency is continuously displayed in the left window, while the right window will display either the standby frequency or the selected readout from the built-in electronic timer.

The built-in electronic timer has two timing functions that operate independently. An automatic flight timer starts when the unit is turned on. This timer counts up to 59 hours and 59 minutes. An elapsed timer will count up or down for up to 59 minutes and 59 seconds. When a preset time interval has been programmed and the countdown reaches :00, the display will flash for 15 seconds. Since both the flight timer and elapsed timer operate independently, it is possible to monitor either one without disrupting the other. The pushbutton controls are internally lighted. The light intensity is controlled by the AVIONICS dimmer control.

(Continued Next Page)

BENDIX/KING KR87 AUTOMATIC DIRECTION FINDER (ADF)

B4218

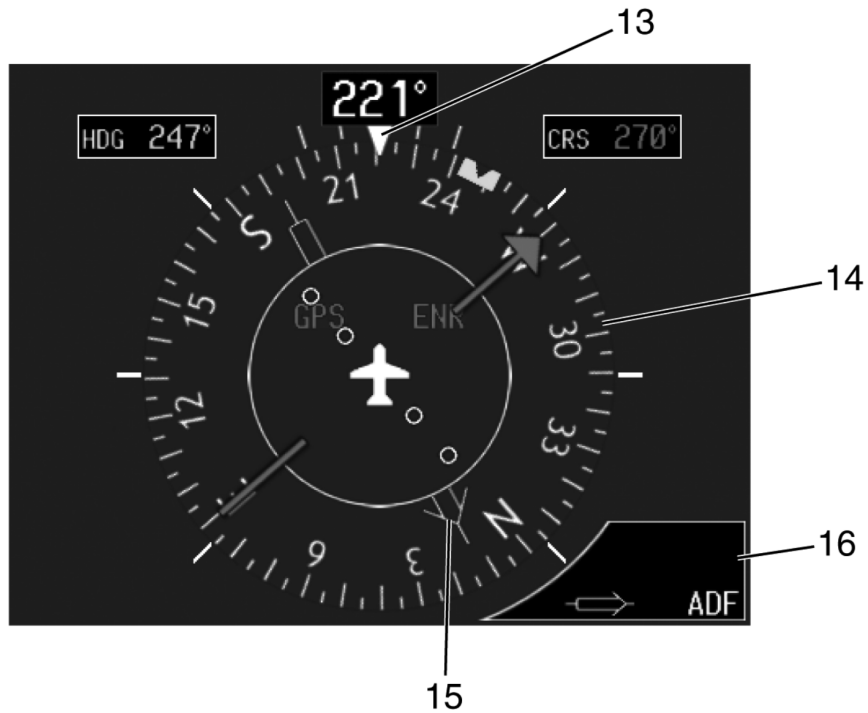
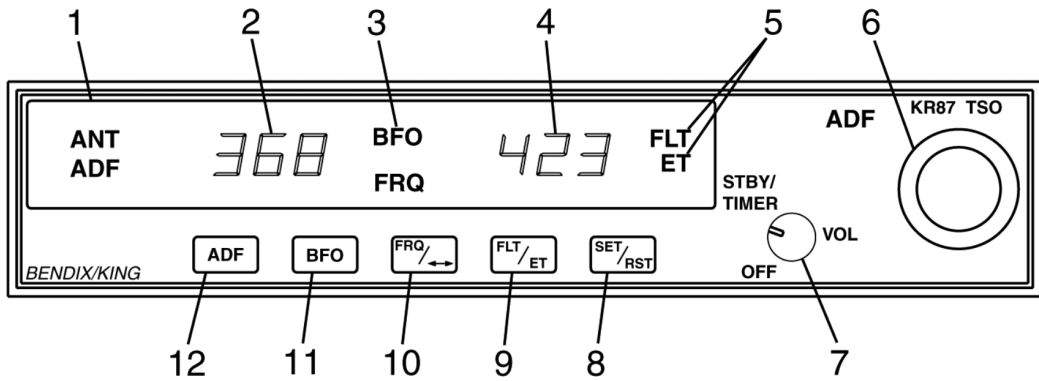

0585T1043
0585T1065

Figure S4-1

GENERAL (Continued)

1. **ANT/ADF MODE ANNUNCIATOR** - Antenna (ANT) is selected when the ADF button is in the OUT position. This mode improves the audio reception and is usually used for station identification. The bearing pointer is deactivated and will park in the 90° relative position. Automatic Direction Finder (ADF) mode is selected by pushing the ADF button. This mode activates the bearing pointer and will point in the direction of the station relative to the aircraft heading.
2. **ACTIVE FREQUENCY DISPLAY** - The frequency to which the ADF is tuned is displayed here. The active ADF frequency can be changed directly when either of the timer functions is selected.
3. **BFO (Beat Frequency Oscillator) ANNUNCIATOR** - The BFO mode is activated and annunciated by pushing the BFO button. When BFO mode is active, the carrier wave and its morse code identifier can be heard.

NOTE

CW signals (Morse Code) are unmodulated and no audio will be heard without use of BFO. This type of signal is not used in the United States air navigation. It is used in some foreign countries and marine beacons.

4. **STANDBY FREQUENCY/FLIGHT TIME OR ELAPSED TIME DISPLAY** - When FRQ is shown, the STANDBY frequency is shown in the right display. The STANDBY frequency is selected using the frequency select knobs. The selected STANDBY frequency is put into the active frequency window by pushing the frequency transfer button. Either the standby frequency, the flight timer, or the elapsed time is shown in this position. The flight timer and elapsed timer replace the standby frequency which goes into blind memory to be called back at any time by pushing the FRQ button. Flight time or elapsed time are shown and annunciated by depressing the FLT/ET button.
5. **FLIGHT TIMER AND ELAPSED TIMER MODE ANNUNCIATION** - Either the elapsed time (ET) or flight time (FLT) mode is annunciated here.

(Continued Next Page)

GENERAL (Continued)

6. **FREQUENCY SELECT KNOBS** - Selects the standby frequency when FRQ is displayed and directly selects the active frequency whenever either of the time functions is selected. The frequency selector knobs may be turned either clockwise or counterclockwise. The small knob is pulled out to tune the 1's. The small knob is pushed in to tune the 10's. The outer knob tunes the 100's with rollover into the 1000's up to 1799. These knobs are also used to set the desired time when the elapsed timer is used in the countdown mode.
7. **ON/OFF/VOLUME CONTROL SWITCH (ON/OFF/VOL)** - Controls power and audio output level. Turn the control switch clockwise from the OFF position to energize the receiver and increase audio volume. The KR87 has audio muting which causes the audio output to be muted unless the receiver is locked on a valid station.
8. **SET/RESET ELAPSED TIMER BUTTON (SET/RST)** - The SET/RST button resets the elapsed timer whether it is being displayed or not.
9. **FLIGHT TIMER/ELAPSED TIMER MODE SELECTOR BUTTON (FLT/ET)** -- The FLT/ET button selects either Flight Timer mode or Elapsed Timer mode when pushed.
10. **FREQUENCY TRANSFER BUTTON (FRQ)** - The FRQ transfer button interchanges the active and standby frequencies when pushed.
11. **BFO (Beat Frequency Oscillator) BUTTON** - The BFO button selects the BFO mode when pushed in. (See note under item 3).
12. **ADF BUTTON** - The ADF button selects either the ANT mode or the ADF mode. The ANT mode is selected when the ADF button is in the out position. The ADF mode is selected when the ADF button is pushed in.
13. **LUBBER LINE** - Indicates magnetic heading of the airplane.
14. **ROTATING COMPASS ROSE (HSI COMPASS CARD)** - The rotating compass rose turns as the heading of the airplane changes. The magnetic heading of the airplane is under the lubber line.
15. **BEARING POINTER** - Shows magnetic bearing to the station.
16. **BEARING INFORMATION WINDOW** - Shows the type of pointer that is being used as the ADF bearing pointer. If ADF is not shown, push the BRG1 or BRG2 softkey until ADF is shown.

OPERATING LIMITATIONS

Refer to Section 2 of the Pilot's Operating Handbook and FAA Approved Flight Manual (POH/AFM).

EMERGENCY PROCEDURES

There is no change to the airplane emergency procedures when the Bendix/King KR 87 Automatic Direction Finder (ADF) is installed.

NORMAL PROCEDURES

TO OPERATE AS AN AUTOMATIC DIRECTION FINDER:

1. OFF/VOL Control - ON
2. Frequency Selector Knobs - SELECT desired frequency in the standby frequency display.
3. FRQ Button - PUSH to move the desired frequency from the standby to the active position.
4. ADF Selector Switch (on audio control panel) - SELECT as desired.
5. OFF/VOL Control - SET to desired volume level and identify that desired station is being received.
6. PFD Softkey (on PFD) - PUSH to show BRG1 and BRG2 softkeys.
7. BRG1 or BRG2 Softkey (on PFD) - PUSH to show ADF in Bearing Information Window.
8. ADF Button - SELECT ADF mode and note magnetic bearing on HSI.

(Continued Next Page)

NORMAL PROCEDURES (Continued)

ADF TEST (PREFLIGHT or IN FLIGHT):

1. ADF Button - SELECT ANT mode and note pointer moves to 90° position.
2. ADF Button - SELECT ADF mode and note the pointer moves without hesitation to the station bearing. Excessive pointer sluggishness, wavering or reversals indicate a signal that is too weak or a system malfunction.

TO OPERATE BFO:

1. OFF/VOL Control - ON
2. BFO Button - PRESS ON
3. ADF Selector Buttons (on audio control panel) - SET to desired mode.
4. VOL Control - ADJUST to desired listening level.

NOTE

A 1000-Hz tone and Morse Code identifier is heard in the audio output when a CW signal is received.

TO OPERATE FLIGHT TIMER:

1. OFF/VOL Control - ON
2. FLT/ET Mode Button - PRESS (once or twice) until FLT is annunciated. Timer will already be counting since it is activated by turning the unit on.
3. OFF/VOL Control - OFF and then ON if it is desired to reset the flight timer.

TO OPERATE AS A COMMUNICATIONS RECEIVER ONLY:

1. OFF/VOL Control - ON
2. ADF Button - SELECT ANT mode
3. Frequency Selector Knobs - SELECT desired frequency in the standby frequency display.
4. FRQ Button - PRESS to move the desired frequency from the standby to the active position.
5. ADF Selector Buttons (on audio control panel) - SET to desired mode.
6. VOL Control - ADJUST to desired listening level.

(Continued Next Page)

NORMAL PROCEDURES (Continued)

TO OPERATE ELAPSED TIME TIMER-COUNT UP MODE:

1. OFF/VOL Control - ON
2. FLT/ET Mode Button - PRESS (once or twice) until ET is annunciated.
3. SET/RST Button - PRESS momentarily to reset elapsed timer to zero.

NOTE

The Standby Frequency which is in memory while Flight Time or Elapsed Time modes are being displayed may be called back by pushing the FRQ button, then transferred to active by pushing the FRQ button again.

TO OPERATE ELAPSED TIME TIMER COUNT DOWN MODE:

1. OFF/VOL Control - ON
2. FLT/ET Mode Button - PRESS (once or twice) until ET is annunciated.
3. SET/RST Button - PRESS until the ET annunciation begins to flash.
4. FREQUENCY SELECTOR KNOBS - SET desired time in the elapsed time display. The small knob is pulled out to tune the 1's. The small knob is pushed in to tune the 10's. The outer knob tunes minutes up to 59 minutes.

NOTE

Selector knobs remain in the time set mode for 15 seconds after the last entry or until the SET/RST, FLT/ET or FRQ button is pressed.

(Continued Next Page)

NORMAL PROCEDURES (Continued)

TO OPERATE ELAPSED TIME TIMER COUNT DOWN MODE: (Continued)

5. SET/RST Button - PRESS to start countdown. When the timer reaches 0, it will start to count up as display flashes for 15 seconds.

NOTE

While FLT or ET are displayed, the active frequency on the left side of the window may be changed, by using the frequency selector knobs, without any effect on the stored standby frequency or the other modes.

ADF OPERATION NOTES:

ERRONEOUS ADF BEARING DUE TO RADIO FREQUENCY PHENOMENA:

In the U.S., the FCC, which assigns AM radio frequencies, occasionally will assign the same frequency to more than one station in an area. Certain conditions, such as Night Effect, may cause signals from such stations to overlap. This should be taken into consideration when using AM broadcast stations for navigation.

Sunspots and atmospheric phenomena may occasionally distort reception so that signals from two stations on the same frequency will overlap. For this reason, it is always wise to make positive identification of the station being tuned, by switching the function selector to ANT and listening for station call letters.

In the vicinity of electrical storms, an ADF indicator pointer tends to swing from the station tuned toward the center of the storm.

(Continued Next Page)

NORMAL PROCEDURES (Continued)

ADF OPERATION NOTES: (Continued)

NIGHT EFFECT:

This is a disturbance particularly strong just after sunset and just after dawn. An ADF indicator pointer may swing erratically at these times. If possible, tune to the most powerful station at the lowest frequency. If this is not possible, take the average of pointer oscillations to determine station bearing.

MOUNTAIN EFFECT:

Radio waves reflecting from the surface of mountains may cause the pointer to fluctuate or show an erroneous bearing. This should be taken into account when taking bearings over mountainous terrain.

COASTAL REFRACTION:

Radio waves may be refracted when passing from land to sea or when moving parallel to the coastline. This also should be taken into account.

PERFORMANCE

There is no change in airplane performance when the Bendix/King KR 87 Automatic Direction Finder (ADF) is installed. However, the installation of an externally mounted antenna or related external antennas, will result in a minor reduction in cruise performance.

Pilot's Operating Handbook And FAA Approved Airplane Flight Manual **SKYLANE**

CESSNA MODEL 182T

NAV III AVIONICS OPTION - GFC 700 AFCS

Serials 18281869 and 18281876 and On

SUPPLEMENT 5

WINTERIZATION KIT

SERIAL NO. _____
REGISTRATION NO. _____

This supplement must be inserted into Section 9 of the Pilot's Operating Handbook and FAA Approved Airplane Flight Manual when the Winterization Kit is installed.

APPROVED BY

FAA APPROVED UNDER 14 CFR PART 21 SUBPART J
Cessna Aircraft Co.
Delegation Option Authorization DOA-290694-CE

Richard D. Murphy DOA Administrator



Member of GAMA

DATE OF APPROVAL 02-13-07

13 FEBRUARY 2007

COPYRIGHT © 2007
CESSNA AIRCRAFT COMPANY
WICHITA, KANSAS, USA

SUPPLEMENT 5

WINTERIZATION KIT

Use the Log of Effective Pages to determine the current status of this supplement.

Pages affected by the current revision are indicated by an asterisk (*) preceding the page number.

Supplement Status

Original Issue

Date

13 February 2007

LOG OF EFFECTIVE PAGES

Page
Number

S5-1 thru S5-6

Page
Status

Original

Revision
Number

0

SERVICE BULLETIN CONFIGURATION LIST

The following is a list of Service Bulletins that are applicable to the operation of the airplane, and have been incorporated into this supplement. This list contains only those Service Bulletins that are currently active.

<u>Number</u>	<u>Title</u>	<u>Airplane Serial</u> <u>Effectivity</u>	<u>Revision</u> <u>Incorporated</u>	<u>Incorporated</u> <u>in Airplane</u>
---------------	--------------	--	--	---

WINTERIZATION KIT

GENERAL

The winterization kit consists of two cover plates, with placards, which attach to the air intakes in the cowling nose cap, a placard silk screened on the instrument panel, and insulation for the crankcase breather tube. This equipment should be installed for operations in temperatures consistently below 20°F (-7°C). Once installed, the crankcase breather insulation is approved for permanent use in both hot and cold weather operations.

B7544

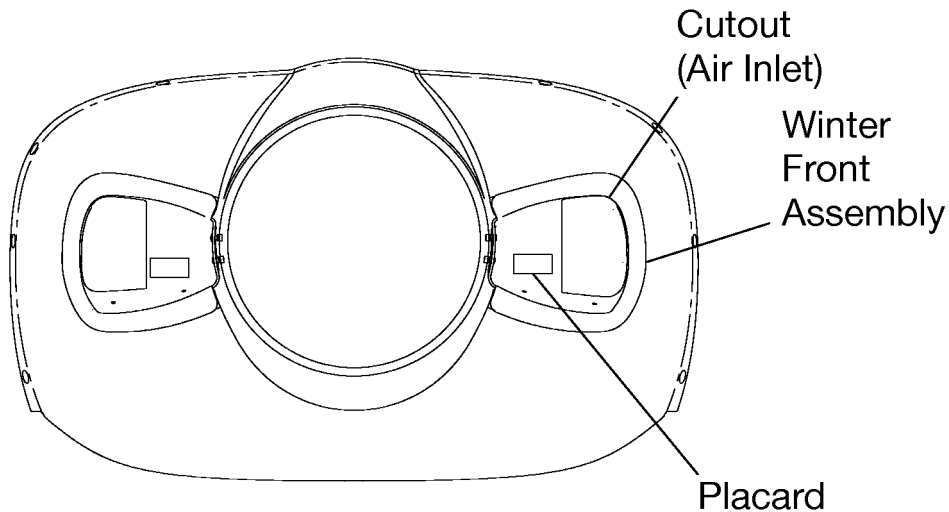

Figure S5-1

OPERATING LIMITATIONS

The following information must be presented in the form of placards when the airplane is equipped with a winterization kit.

1. On each nose cap cover plate:

B6541

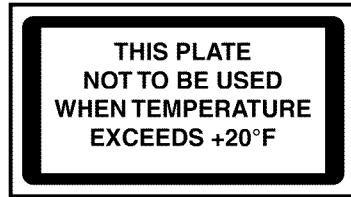

2. On the instrument panel below the PFD:

B7545

**WINTERIZATION KIT MUST BE
REMOVED WHEN OUTSIDE AIR
TEMPERATURE IS ABOVE 20° F.**

EMERGENCY PROCEDURES

There is no change to the airplane emergency procedures when the winterization kit is installed.

NORMAL PROCEDURES

There is no change to the airplane normal procedures when the winterization kit is installed.

PERFORMANCE

There is no change to the airplane performance when the winterization kit is installed.



Pilot's Operating Handbook And FAA Approved Airplane Flight Manual **SKYLANE**

CESSNA MODEL 182T

NAV III AVIONICS OPTION - GFC 700 AFCS

Serials 18281869 and 18281876 and On

SUPPLEMENT 6

JAR-OPS OPERATIONAL ELIGIBILITY

SERIAL NO. _____
REGISTRATION NO. _____

This supplement must be inserted into Section 9 of the Pilot's Operating Handbook and FAA Approved Airplane Flight Manual for JAR-OPS Operational Eligibility.

APPROVED BY

FAA APPROVED UNDER 14 CFR PART 21 SUBPART J
Cessna Aircraft Co.
Delegation Option Authorization DOA-230564-CE

R. S. [Signature]
Administrative AR
R/S



Member of GAMA

DATE OF APPROVAL 16 November 2006

16 NOVEMBER 2006

COPYRIGHT © 2006
CESSNA AIRCRAFT COMPANY
WICHITA, KANSAS, USA

SUPPLEMENT 6

JAR-OPS OPERATIONAL ELIGIBILITY

Use the Log of Effective Pages to determine the current status of this supplement.

Pages affected by the current revision are indicated by an asterisk (*) preceding the page number.

Supplement Status

Original Issue

Date

16 November 2006

LOG OF EFFECTIVE PAGES

Page Number	Page Status	Revision Number
S6-1 thru S6-5/S6-6	Original	0

SERVICE BULLETIN CONFIGURATION LIST

The following is a list of Service Bulletins that are applicable to the operation of the airplane, and have been incorporated into this supplement. This list contains only those Service Bulletins that are currently active.

<u>Number</u>	<u>Title</u>	<u>Airplane Serial</u> <u>Effectivity</u>	<u>Revision</u> <u>Incorporated</u>	<u>Incorporated</u> <u>in Airplane</u>
---------------	--------------	--	--	---

JAR-OPS OPERATIONAL ELIGIBILITY

GENERAL

OPERATIONAL ELIGIBILITY

The JAA TGLs noted below specify that Operational Eligibility information be included in the airplane POH/AFM or POH/AFM Supplement for convenience in the JAR-OPS approval process. This Supplement provides a consistent location for the requested information. This information does not address the operation of the airplane or equipment by the pilot.

NAVIGATION OPERATIONAL ELIGIBILITY

The GPS/GNSS receivers in the G1000 System are certified to TSO C129a Class A1 and ETSO C129a Class A1 or TSO C145a and ETSO 2C145a.

The installed performance of the G1000 System has been tested and approved for IFR enroute, terminal and non-precision (RNAV or GPS) approach operations per AC 20-138A when using GPS/GNSS with the correct navigation database.

The G1000 System meets the requirements for GPS/GNSS as a Primary Means of Navigation for Oceanic/Remote Operations (RNP-10) per AC 20-138A, FAA Notice N8110.60, FAA Order 8400-12A and FAA Order 8700-1. Both GPS/GNSS receivers are required to be operating and receiving usable signals except for routes requiring only one Long Range Navigation sensor.

The G1000 System has been shown to be eligible for BRNAV (RNP-5) and PRNAV (RNP-1) Enroute and Terminal navigation per JAA TGL-2 (ACJ20X4), JAA TGL-10 and AC 90-96A provided that the G1000 is receiving usable navigation information from at least one GPS receiver. Eligibility does not constitute Operational Approval.

(Continued Next Page)

GENERAL (Continued)

SSR MODE S ENHANCED SURVEILLANCE OPERATIONAL ELIGIBILITY

The GTX 33 Transponder is certified to TSO C112a and ETSO 2C112a. The installed performance of the GTX 33 has been tested and approved per AC 20-131A, Draft AC-131B and AC 23-8B.

The GTX 33 is able to respond to interrogations in Modes A, C and is fully compliant with the requirements of Mode S Elementary Surveillance per TGL 13 Rev 1 and Draft TGL 13 Rev 2. Extended Squitter functionality is supported by the GTX 33. This does not constitute airworthiness or operational approval for Extended Squitter functionality.

OPERATING LIMITATIONS

There is no change to the airplane operating limitations for JAR-OPS Operational Eligibility. JAR-OPS may require separate airspace operating limitations.

EMERGENCY PROCEDURES

There is no change to the airplane emergency procedures for JAR-OPS Operational Eligibility.

NORMAL PROCEDURES

There is no change to the airplane normal procedures for JAR-OPS Operational Eligibility.

PERFORMANCE

There is no change to the airplane performance for JAR-OPS Operational Eligibility.

Pilot's Operating Handbook And FAA Approved Airplane Flight Manual **SKYLANE**

CESSNA MODEL 182T
NAV III AVIONICS OPTION - GFC 700 AFCS
Serials 18281869 and 18281876 and On

SUPPLEMENT 7
CANADIAN CERTIFIED AIRPLANES

SERIAL NO. _____
REGISTRATION NO. _____

This supplement must be inserted into Section 9 of the Pilot's Operating Handbook and FAA Approved Airplane Flight Manual for Canadian Certified Airplanes.

APPROVED BY

FAA APPROVED UNDER 14 CFR PART 21 SUBPART J
Cessna Aircraft Co.
Delegation Option Authorization DOA-230594-CE

 Administrative AR



Member of GAMA

DATE OF APPROVAL 06 February 2007

6 FEBRUARY 2007

COPYRIGHT © 2007
CESSNA AIRCRAFT COMPANY
WICHITA, KANSAS, USA

SUPPLEMENT 7

CANADIAN CERTIFIED AIRPLANES

Use the Log of Effective Pages to determine the current status of this supplement.

Pages affected by the current revision are indicated by an asterisk (*) preceding the page number.

Supplement Status

Original Issue

Date

6 February 2007

LOG OF EFFECTIVE PAGES

Page Number	Page Status	Revision Number
S7-1 thru S7-5/S7-6	Original	0

SERVICE BULLETIN CONFIGURATION LIST

The following is a list of Service Bulletins that are applicable to the operation of the airplane, and have been incorporated into this supplement. This list contains only those Service Bulletins that are currently active.

<u>Number</u>	<u>Title</u>	<u>Airplane Serial</u> <u>Effectivity</u>	<u>Revision</u> <u>Incorporated</u>	<u>Incorporated</u> <u>in Airplane</u>
---------------	--------------	--	--	---

CANADIAN CERTIFIED AIRPLANES

GENERAL

This supplement is required for Canadian operation of Cessna Model 182T airplanes equipped with the Nav III GFC 700 AFCS avionics option.

NOTE

In Canada, FAA operating rules (i.e., 14 CFR Part 91 and 14 CFR Part 135) are not applicable. The airplane must be equipped and operated in accordance with Transport Canada.

The Artex ME406 Emergency Locator Transmitter installation is not approved for Canadian Certified Airplanes.

OPERATING LIMITATIONS

There is no change to the airplane operating limitations for Canadian Certified Airplanes.

EMERGENCY PROCEDURES

There is no change to the airplane emergency procedures for Canadian Certified Airplanes.

NORMAL PROCEDURES

There is no change to the airplane normal procedures for Canadian Certified Airplanes.

PERFORMANCE

There is no change to the airplane performance for Canadian Certified Airplanes.



Pilot's Operating Handbook And FAA Approved Airplane Flight Manual **SKYLANE**

CESSNA MODEL 182T
NAV III AVIONICS OPTION - GFC 700 AFCS
Serials 18281869 and 18281876 and On

SUPPLEMENT 8

BRAZILIAN CERTIFIED AIRPLANES

SERIAL NO. _____
REGISTRATION NO. _____

This supplement must be inserted into Section 9 of the Pilot's Operating Handbook and FAA Approved Airplane Flight Manual when used for Brazilian Certified Airplanes and is approved by the U.S. Federal Aviation Administration (FAA) on behalf of the "Agência Nacional de Aviação Civil" (ANAC) for Brazilian Registered Airplanes, in accordance with the "Regulamento Brasileiro de Homologação Aeronáutica" (RBHA) Part 21, Section 21.29.

APPROVED BY

FAA APPROVED UNDER 14 CFR PART 21 SUBPART J
Cessna Aircraft Co.
Delegation Option Authorization DOA-230564-CE

R. Schell Administrative AR



Member of GAMA

DATE OF APPROVAL 20 JUNE 2007

20 JUNE 2007

COPYRIGHT © 2007
CESSNA AIRCRAFT COMPANY
WICHITA, KANSAS, USA

182TPHBUS-S8-00

U.S.

S8-1

SUPPLEMENT 8

BRAZILIAN CERTIFIED AIRPLANES

Use the Log of Effective Pages to determine the current status of this supplement.

Pages affected by the current revision are indicated by an asterisk (*) preceding the page number.

<u>Supplement Status</u>	<u>Date</u>
Original Issue	20 June 2007

LOG OF EFFECTIVE PAGES

Page Number	Page Status	Revision Number
S8-1 thru S8-5/S8-6	Original	0

SERVICE BULLETIN CONFIGURATION LIST

The following is a list of Service Bulletins that are applicable to the operation of the airplane, and have been incorporated into this supplement. This list contains only those Service Bulletins that are currently active.

<u>Number</u>	<u>Title</u>	<u>Airplane Serial</u> <u>Effectivity</u>	<u>Revision</u> <u>Incorporated</u>	<u>Incorporated</u> <u>in Airplane</u>
---------------	--------------	--	--	---

GENERAL

This supplement is required for Brazilian operation of Cessna Model 182T airplanes equipped with the Nav III GFC 700 AFCS avionics option.

OPERATING LIMITATIONS

There is no change to the airplane operating limitations when used for Brazilian Certified Airplanes.

EMERGENCY PROCEDURES

There is no change to the airplane emergency procedures when used for Brazilian Certified Airplanes.

NORMAL PROCEDURES

There is no change to the airplane normal procedures when used for Brazilian Certified Airplanes.

PERFORMANCE

There is no change to the airplane performance when used for Brazilian Certified Airplanes.

LOG OF ANAC APPROVED SUPPLEMENTS

The following list contains ANAC accepted supplements. Refer to Log of Approved Supplements in the basic Pilot's Operating Handbook and FAA Approved Airplane Flight Manual for revision status.

Supplement Number	Name	Equipment Installed
1	Artex ME406 Emergency Locator Transmitter (ELT)	_____
2	Artex C406-N Emergency Locator Transmitter (ELT)	_____
3	L3 Communications WX-500 Stormscope	_____
4	Bendix/King KR 87 Automatic Direction Finder (ADF)	_____
5	Winterization Kit	_____
6	Reserved	_____
7	Reserved	_____
8	Brazilian Certified Airplanes	_____

